

BRINLY



Model VV-100

30" ROTOTILLER (Electric) OWNER'S USE AND CARE MANUAL



Approved for use with
GENERAL ELECTRIC COMPANY



Electrak

Garden Tractor

BRINLY-HARDY COMPANY, Inc., 340 E. Main Street, Louisville, Ky. 40202

CONTENTS

	Page		Page
Attaching Tiller to hitch bar	6	Removing Tiller hitch bar	6
Depth control	2	Rototiller starting	3
Efficiency and economy	3	Safety practices	1
Electric lift installation	5	Service and maintenance	6
Ground speed	2	Specifications	7
Operating tips	4	Tiller hitch bar installation	5
Operation	2	Tilling aggressiveness	3
Preparation of Tiller	4	Transporting	2
		Warranty	7

INTRODUCTION

The Brinly Rototiller is the result of careful design engineering with the operator foremost in mind. Safety, ease of attachment and operation, ruggedness, and maintenance-free features are built into the Brinly Rototiller. To complete the Rototiller and make it operable, two accessories are required: Tiller Mounting Bracket, VV-101, and G.E. Electric Lift (rear), AP59, available from General Electric Co.

This manual has been carefully prepared to instruct you in attaching, operating, maintaining, and lubricating your

Rototiller. IT IS VERY IMPORTANT THAT EACH OPERATOR FULLY UNDERSTAND THE ENTIRE CONTENTS OF THIS MANUAL FOR SAFE, DEPENDABLE OPERATION AND TO PROLONG THE LIFE OF THE EQUIPMENT. Also included are suggestions that make use of this attachment easier and more enjoyable. Your Elec-Trak tractor dealer is equipped to service your equipment for safe, efficient, and economical operation. UNAUTHORIZED SERVICE VOIDS WARRANTY.

SAFETY PRACTICES

As with all power devices, prime responsibility for safe operation of the equipment rests with the operator. It is necessary that both the operating instructions and the following safety information be fully understood by each operator before using the tractor and attachments.

Become familiar with the location and function of all controls.

Be sure the work area is clear of objects which might be picked up and thrown.

Regulate travel speed according to ground conditions.

Don't forget to set the brake and shut off attachment power before you leave the tractor.

Don't drive too close to creeks or ditches.

Watch out for traffic when near roadways.

Stay alert for holes and other hidden hazards.

Watch where you're driving! Pay attention!

Beware of steep slopes! Reduce speed on all side slopes and sharp turns to prevent tipping or losing control.

Don't attempt to operate tractor when not in seat.

Don't carry passengers without proper provisions.

Keep children and pets at a safe distance.

Don't wear loose-fitting clothing that might get caught in moving parts.

Never attempt to get off the tractor while it is in motion.

Don't stop or start suddenly when going uphill or downhill.

Keep tractor in good operating condition.

Remove key before leaving tractor.

Plug tractor charger cord into a normal 110 volt, 3-hole receptacle. Do not use a 2-hole adapter unless properly grounded.

Keep hands and feet clear of all rotating equipment.

Disconnect power cord from PTO receptacle before handling power attachments.

All safety devices are for your protection. Do not attempt to defeat them.

OPERATION

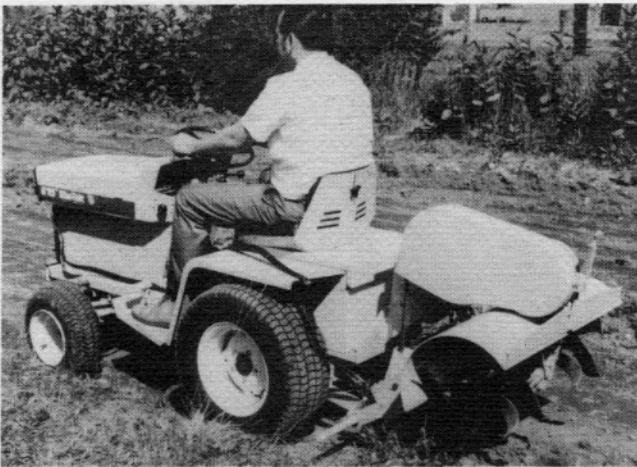

FIG. 1 – BRINLY ROTOTILLER

General

The right and left hand side of the tractor or the Rototiller is identified when sitting properly on the tractor seat.

Prior to initial use of the Brinly Rototiller, the user should completely familiarize himself with all tractor controls. This information and general attachment operating information is found in your Elec-Trak tractor Use and Care Manual. Refer to your manuals often!

The power pack should be fully charged before any tilling is performed. This will allow the maximum area to be tilled and extend the serviceability of the power pack. Since all tilling operations require larger amounts of power than are encountered in operations such as mowing, the electrolyte level in each cell of the power pack should be checked and adjusted at least once per week or every 5 tilling discharges.

Ground Speed

All tilling should be done with the range selector in the lowest (LL) range. This allows proper ground preparation and helps prevent the tiller from pushing the tractor when hard spots are encountered.

CAUTION:

Never reverse tractor with tiller tines in the soil. This could result in equipment damage.

TRANSPORTING

Refer to Fig. 2

Rototiller is raised and lowered with the electric rear lift (A). Once the tiller is fully raised (when tiller frame contacts lift limiter (B), the depth control chain (C) should be attached to the upper end of the lift so a minimum amount of slack remains in the chain fastening to the rototiller frame. Next, run the lift down to remove all tension from the lift strap.

WARNING:

With the tiller in the raised position, the front tractor wheels support less weight, so steering effectiveness is reduced. We strongly recommend leaving mower mounted on front of tractor when tilling. If you don't have the mower, you should purchase front end wheel weights or a model No. LL 270 BRINLY Gard-N-Cart. As an added precaution, back up steep hills and avoid side travel on slopes, with tiller in transport position.

Depth Control

While on a flat surface, lower the tiller until the tines just touch the surface. Draw the depth control chain taut and attach it to the lift in the usual manner. Mark this link permanently. This establishes the ground level reference and allows depth to be increased by adding more links below the lift attachment point. One link equals approximately one inch of depth in soil. Set the chain and lower the tiller until the lift strap becomes slack.

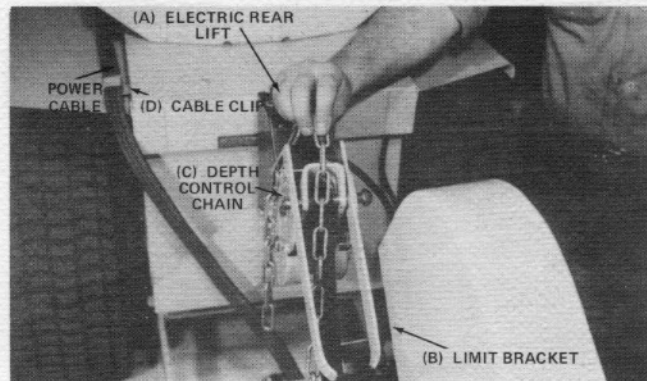

FIG. 2 – DEPTH CONTROL CHAIN

CAUTION:

While raising or lowering the Rototiller, position loose end of depth control chain as shown in Fig. 2 to prevent fouling of the lift mechanism.

The tiller should till six inches deep. On the initial pass, in hard ground, full depth tilling should be avoided. Subsequent passes will allow full penetration and, because the housing and tractor tires will sink into the loose earth, additional tilling depth will result.

OPERATION

Efficiency and Economy

Refer to Fig. 3

In any tilling operation, depth of till and forward speed should be regulated to keep the power use indicator in the yellow zone most of the time. Continued tilling with power use indications in the upper red zone will result in power interruption to the tiller motor by opening a circuit breaker. The circuit breaker (a) is located on the left side of the tiller just forward of the tine housing. In the event that the circuit breaker opens, turn the PTO switch "off" and, after allowing a few minutes for cooling, press the red button into its reset position. The tiller can then be restarted by switching the PTO back on.

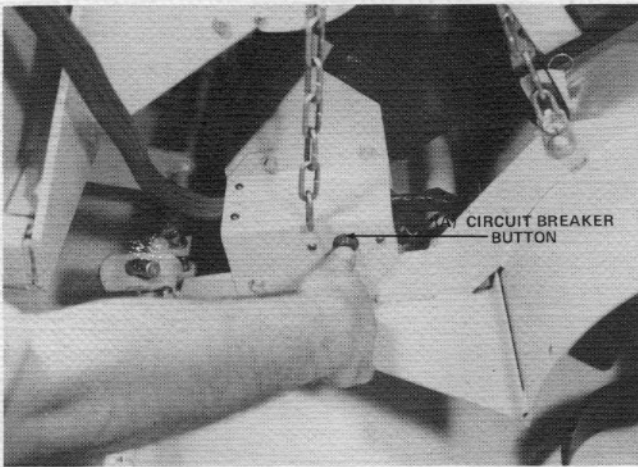

FIG. 3 – MANUAL RESET CIRCUIT BREAKER

Rototiller Starting

To begin, stop the tractor with the tiller over the tilling area starting point. Start the tiller motor by sitting on the tractor seat and turning the key switch "on" and turning the PTO switch to "off" and then "on". An electrical interlock prevents the Rototiller from starting if this procedure is not followed. Should the operator leave the seat or turn the key switch to "off", another interlock interrupts Rototiller power. For all normal use, the PTO switch should be used to turn the tiller "on" and "off". To restart, the PTO switch must be turned to "off" and then to "on". Refer to your tractor manual.

CAUTION:

Before leaving the tractor for any reason, turn PTO and key switches to "off".

With the tiller running and the tractor stopped, lower the tiller until the tines engage the soil. Continue to lower the tiller gradually so as not to overload the attachment. (The rate of penetration is dependent on the type and condition of the soil.) Just before the desired tilling depth is achieved,

attach the depth control chain as outlined in the OPERATION section (Pg. 2) and continue to lower the tiller until all tiller weight is on the chain and the lift strap becomes slack.

NOTE:

By applying the foot brake while lowering the tiller, the tractor will remain stationary.

Release brake fully and advance the speed control to the proper position while the tines are rotating. If tiller action is excessively rough and bouncy in very hard or rocky soil, stop the tractor and raise the tiller depth control chain (See Fig. 2) one link at a time, until desired tilling action is required.

The preferred method of stopping the tiller is with the tines lifted out of the ground; however, should any emergency arise, stop forward motion immediately with tractor brake and turn PTO switch to "off".

CAUTION:

Never continue to power the electric lift after its upper limit has been reached. Damage may occur to the lift or other equipment.

Tilling Aggressiveness

Refer to Fig. 6

The "aggressiveness" of the tiller is determined by the position of the mounting bracket hitch bar. Two positions are available: for easy tilling in soft ground use the lower position (Hole "A"); for aggressive penetration in hard ground use the upper position (Hole "B").

Generally, for garden soil which has been tilled before, the lower position (Hole "A") may be used. For tilling in hard ground, the upper position (Hole "B") may have to be used until one or more passes over the area have been made. Then the lower hitch bar position can be used if further soil pulverization is desired. Refer to the Tiller Mounting Bracket Instructions (Pg. 4) for adjustment of the hitch bar position.

Mounting Bracket Hitch
Bar Position

Position	Use
Lower (Hole "A")	Previously worked soil Sandy soil
Upper (Hole "B")	Heavy sod Hard packed soil Rocky soil Clay-bearing soil

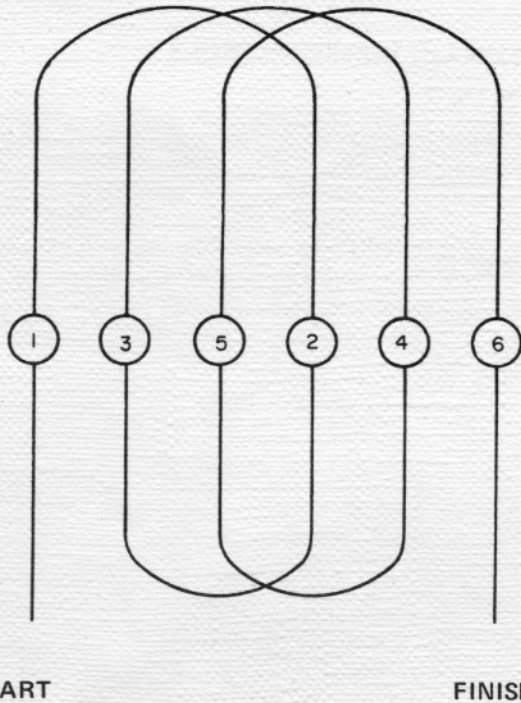

FIG. 4. Tilling Pattern

Operating Tips

Widely varying conditions prevent instructions on specific tilling procedures, but some of the guidelines and tips available follow:

Never till immediately after a heavy rain or rainy period or too early in the Spring.

On virgin soil protect the equipment and have soil worked initially by larger sized farm equipment.

Remove any large stones and trash from the area you plan to rototill. Also, clean tilling area of high grass or weeds by burning or cutting and removing before starting tilling operation.

The pattern shown in Fig. 4 should be followed for typical homeowner's gardens. The second pass should follow the same pattern, but be at a right angle to the first pass.

If jamming occurs, shut the PTO switch "off", remove the power cord from the PTO receptacle and dislodge the jammed piece.

If sharp turns are anticipated, lift tines from the soil before turning to prevent tiller damage.

The tiller can be attached to the hitch bar to provide tilling to the left, right or center of the tractor. With this flexibility, most row crop cultivating may be carried out. Refer to the Installation section, page 5, Figs. 8 & 9.

Preparation of Tiller

Refer to Fig. 5

1. Installation of Tines:

The cutting edge of each tine must face the direction of rotation. With the tine cutting edge facing the direction of rotation, the direction of bend on each end will

determine if it is a right hand or left hand tine. If bend is to the right, it is a right hand tine, and if bend is to the left, it is a left hand tine. Right hand and left hand reference is determined by standing at the rear of the tractor or tiller and facing the direction of forward travel. Secure tine assembly with four 1/2 inch pins and cotter pins.

2. Attaching Spring Tension Rod:

Insert trunnion through hole in outer pivot arm as shown in figure 5. Secure with cotter pin. With drive belt in groove of each pulley, tighten the nut on the threaded stud until the tension spring is compressed to a length of approximately 3-3/4 inches. After adjustment has been made, turn the top nut down to the other and jam together.

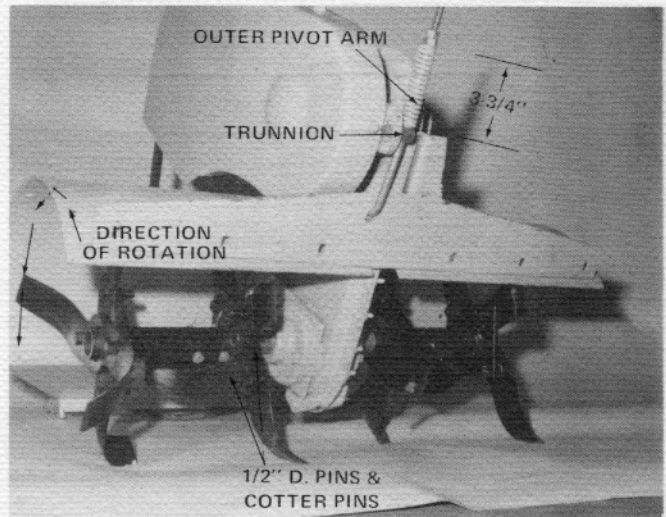

FIG. 5 – PREPARATION OF TILLER

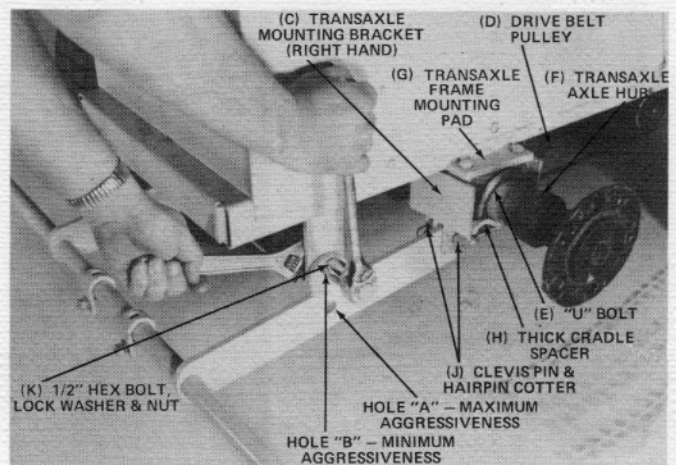

FIG. 6 – HITCH BAR INSTALLATION AND ADJUSTMENT

Tiller Hitch Bar Installation

Refer to Fig. 6

Block the front tractor wheels and jack up the rear of the tractor evenly before removing the rear wheels.

Identify the right transaxle mounting bracket (C) as that with the "cut out" made to accommodate the drive belt pulley (D). Position two "U" bolts (E) (with their legs down) to conform to the transaxle axle hubs – one inside the transaxle frame mounting pad (G) and one outside the pad.

Install a thick cradle spacer (H) on the outside "U" bolt (D) and a thin one on the inside "U" bolt with their curved surfaces facing upward to conform to the transaxle axle hub. Hold the transaxle mounting bracket (C) in place and secure with four lock washers and nuts. **Do not tighten at this time.**

Repeat assembly procedure for the left mounting bracket.

Secure hitch bar to rear holes in transaxle mounting brackets (C) with clevis pins and hair-pin cotters (J), so the cotters are on the inside of the brackets.

Raise hitch bar to align bar holes with tractor rear draw bar holes (side of draw bar). Use the upper pair of hitch bar holes (Hole "B") to give minimum aggression, or the lower pair (Hole "A") for maximum aggression. See page 3, "Aggressiveness."

With the holes aligned, secure hitch bar in place with 1/2 inch bolts, lock washers and nuts (K). Tighten nuts finger tight, adjust mounting brackets as they are tightened so that no binding occurs. Tighten nuts and bolts holding hitch bar to draw bar.

Electrical Lift Installation (Rear)

Refer to Fig. 7

Initial installation of the rear electric left (A) should be performed by your Elec-Trak dealer only.

The lift arms (B) enter the frame openings at the rear of the tractor. Push the assembly in until flush with the rear of the frame, and secure with clevis pin and hair pin cotter (C). Connect the lift receptacle with lift power cord plug.

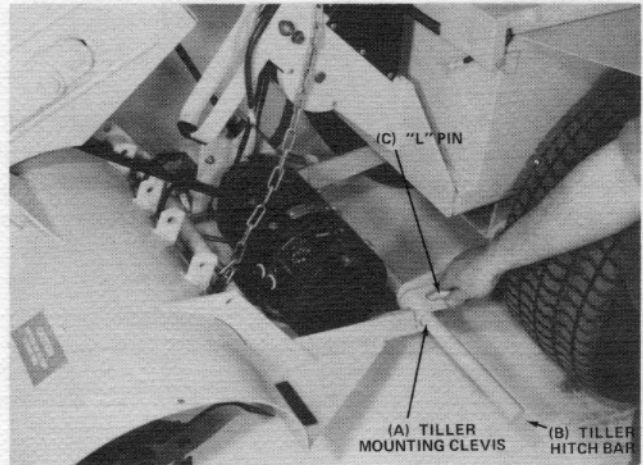

FIG. 8 – TILLER CENTER MOUNTING

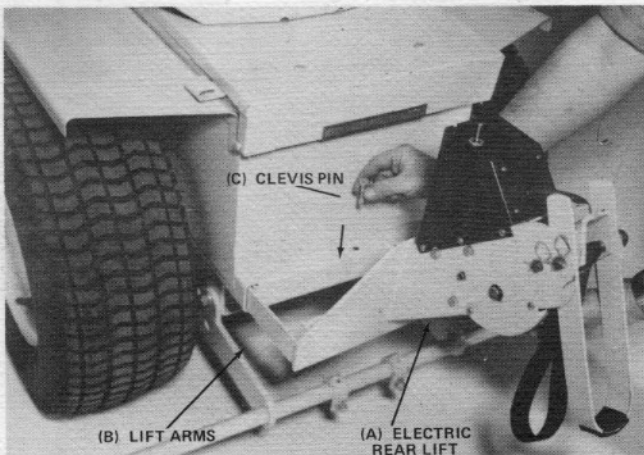

FIG. 7 – ELECTRIC LIFT INSTALLATION

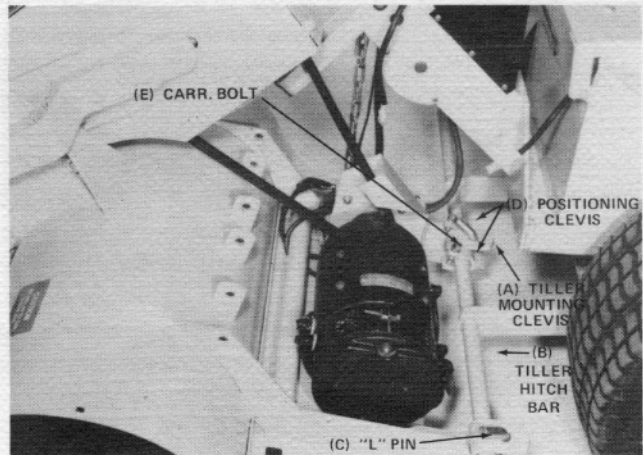

FIG. 9 – TILLER RIGHT HAND MOUNTING

INSTALLATION

Attaching Tiller to Hitch Bar

Refer to Figs. 8 & 9

Block up the front of the tiller so that each mounting clevis (A) is at about the same height as the tiller hitch bar (B). Drive the tractor at the slowest (LL) reverse speed into the tiller so that each clevis engages the hitch bar at the same time. Mounting may be made so tilling can be performed to the left, right (Fig. 9) or center of the tractor (Fig. 8). Drop the "L" shaped clevis pins (C) through the clevis holes and secure each one with a hair-pin cotter. When attaching tiller to right or left position, place one positioning clevis (D) on each side of tiller clevis, at center of hitch bar, and secure by tightening carriage bolts (E).

Refer to Figs. 10 & 11

Run lift strap (A) out approximately 30 inches, double it back on itself, and hold its looped end and lift limiter (B) at top of the lift assembly inside the depth chain locking bracket (C). Pass the 3-1/2 x 1/2 inch clevis pin (D) through the aligned holes of the lift limiter (B), chain locking bracket (C) and lift strap loop (A).

Raise tractor seat and insert power cable clip between fender and battery box (on left hand side). See Fig. 2, (Item "D"). Position the tiller motor power cable over the left tractor fender, fitting it inside the cable clip, along the top edge of the frame, to the right of the brake pedal, and into the PTO receptacle.

Remove block and prepare the tiller for transporting. See page 2. (To remove tiller, reverse above procedure.)

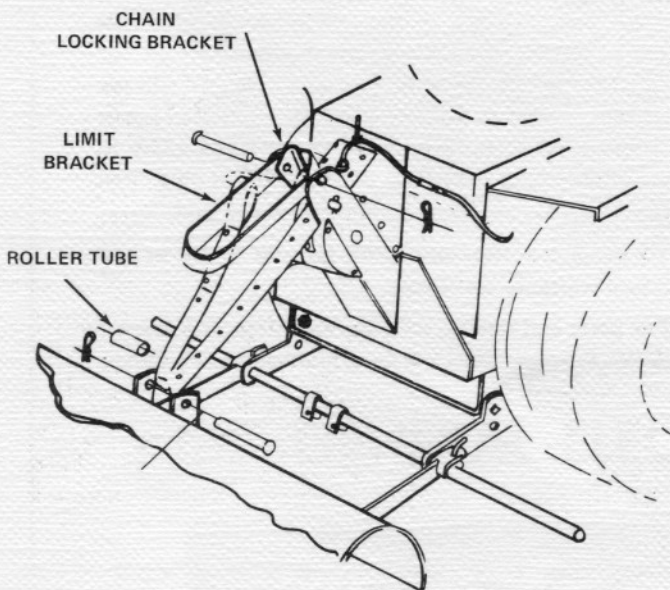

FIG. 10 – ATTACHING LIFT STRAP TO TILLER

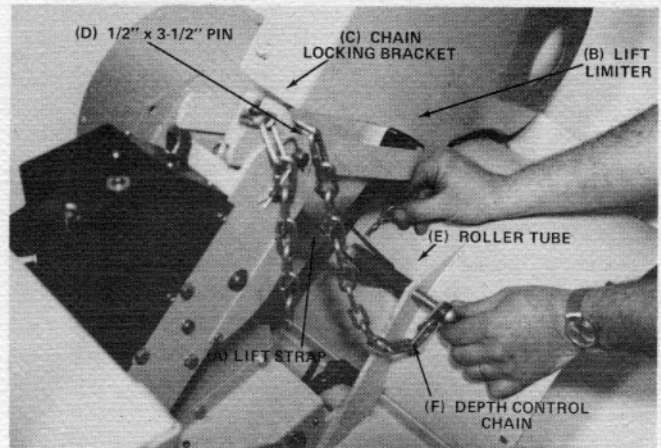

FIG. 11 – ATTACHING LIFT STRAP TO TILLER

Removing the Tiller Hitch Bar

When it becomes necessary to remove the tiller hitch bar, remove the bolts securing the hitch bar to the tractor draw bar and the hair-pin cotters and clevis pins attaching the hitch bar to the transaxle mounting bracket. It is not necessary to remove the transaxle mounting brackets.

SERVICE & MAINTENANCE

Refer to Fig. 12

A few drops of 30 weight machine oil should be placed in the oil cup (A) on the upper portion of chain case before each seasonal use. (See Fig. 12.)

A light coating of 30 weight oil should be wiped on the drive chain before and after storage periods.

For greater than average use, lubrication frequency should be increased accordingly; and before storage, the external drive chain should be cleaned, lubricated and adjusted.

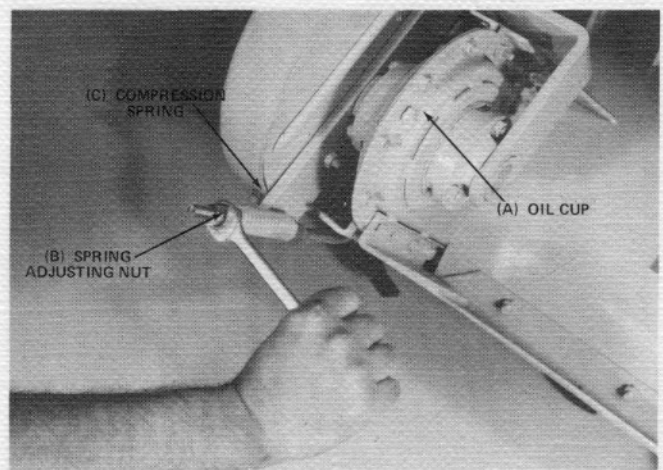

FIG. 12 – BELT TENSION & OIL CUP

Adjustments

The Rototiller torque limiter (40 tooth sprocket assembly) provides protection by slipping when rocks or other debris are encountered. This unit is factory set and self-adjusts for wear. If unit requires service, contact your dealer. Should the drive belt start slipping excessively when tilling normal soil, its tension should be increased. Belt tension is increased by turning the nut on the threaded stud (B) shown in Fig. 12, so as to compress the spring (C). When the desired tension is reached, turn the top nut down to the other to lock them in place. **DO NOT OVER-TIGHTEN BELT.**

SPECIFICATIONS

Tilling Width	30 inches
Tilling Depth (Max.)	6 inches (below plane of rear tractor wheels.)
Tine Speed	120 rpm

WARRANTY

This Brinly product is warranted to the original purchaser for a period of 12 months from date of purchase in ordinary home use, or 90 days in commercial, rental, or institutional use — as follows:

The Brinly-Hardy Company will replace free of charge, F.O.B. authorized Brinly dealer, any PART* found to be defective when returned — TRANSPORTATION CHARGES PREPAID.

*EXCEPTIONS:

1. Drive Belt excluded
2. For warranty and service on electric motor, wiring harness and circuit breaker, contact your General Electric Elec-Trak tractor dealer.

The warranty will not apply to repair or replacement made necessary by normal wear, or to machines altered outside our factory, which alterations, in our judgment affect its life or operation. Neither will the warranty apply to failures from misuse, negligence or accident. The company also reserves the right to incorporate any changes in design, without obligation to make these changes on units previously sold.

To make this warranty valid, be sure to fill in and return warranty certificate.

For parts and service, see your local Elec-Trak tractor dealer. Furnish model and serial number when ordering.