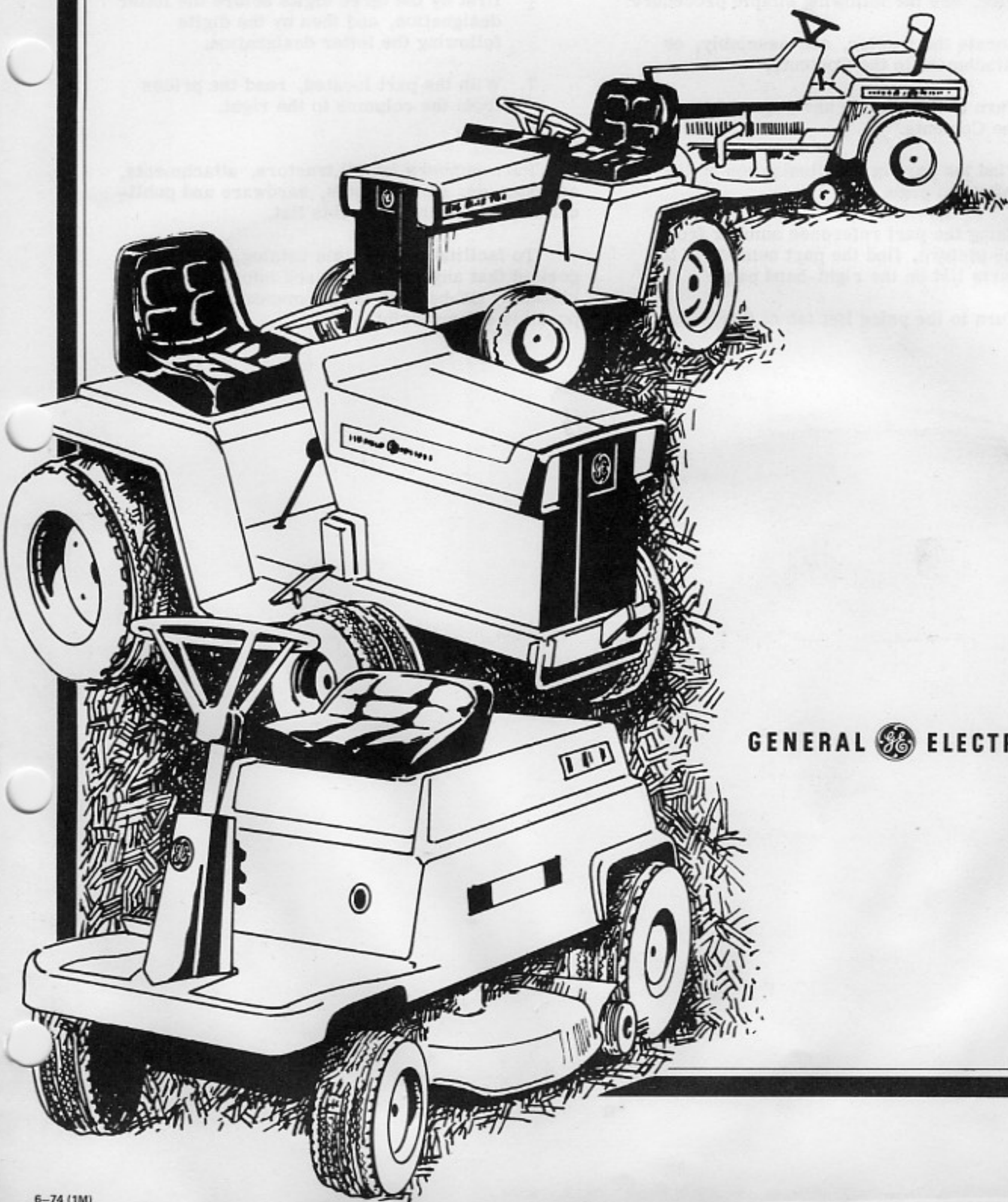

# **Electrak<sup>®</sup>**

Tractor

## **PARTS CATALOG**

GENERAL  ELECTRIC

## HOW TO USE THE ELEC-TRAK TRACTOR PARTS CATALOG

This catalog is your source for complete parts and pricing information. To find any part and its price, use the following simple procedure:

1. Locate the tractor, sub-assembly, or attachment in the Contents.
2. Turn to the section and page listed in the Contents.
3. Find the part in the illustration on the left-hand page.
4. Using the part reference number from the picture, find the part number in the parts list on the right-hand page.
5. Turn to the price list tab of the manual.

6. Locate the part number in the price list. The price list is arranged numerically, first by the three digits before the letter designation, and then by the digits following the letter designation.
7. With the part located, read the prices from the columns to the right.

Part numbers for all tractors, attachments, accessories, service tools, hardware and publications are combined in this list.

To facilitate use of this catalog, it is important that any new or revised information furnished by GE be filed in this manual as soon as possible after receipt.

## CONTENTS

Section		Page
1	E20 Tractor Parts .....	1-1
	Body Components .....	1-3
	Dash Components, E20AA - E20DA .....	1-5
	Dash Components, E20EA, EC, ED, FA, RA .....	1-7
	Electrical Components, E20AA - E20DA .....	1-9
	Electrical Components, E20EA, EC, ED, FA, RA .....	1-11
	Speed Control .....	1-13
2	E15 Tractor Parts .....	2-1
	Body Components .....	2-3
	Dash Components, E15AA - E15GA .....	2-5
	Dash Components, E15HA - JA .....	2-7
	Electrical Components, Upper Control Panel, E15AA - E15GA .....	2-9
	Electrical Components, Lower Control Panel, E15AA - E15GA .....	2-11
	Electrical Components, E15HA, JA .....	2-13
	Speed Control .....	2-15
3	E12s Tractor Parts .....	3-1
	Body Components .....	3-3
	Dash Components .....	3-5
	Electrical Components, Upper Control Panel .....	3-7
	Electrical Components, Lower Control Panel .....	3-9
	Speed Control .....	3-11
4	E12 Tractor Parts .....	4-1
	Body Components .....	4-3
	Dash Components, E12 CA, DA, HA, JA, JD .....	4-5
	Electrical Components, Upper Control Panel, E12CA, DA, HA, E12M EA .....	4-7
	Electrical Components, E12JA, JD .....	4-9
	Speed Control .....	4-11
5	E12M Tractor Parts .....	5-1
	Body Components .....	5-3
	Dash Components .....	5-5
	Electrical Components, E12CA, DA, HA, E12MEA .....	5-7
	Speed Control .....	5-9
6	E8M and E10M Tractor Parts .....	6-1
	Body Components .....	6-3
	Front Battery Compartment, E8M, E8HD .....	6-5
	Front Battery Compartment, E10M .....	6-7
	Dash Components .....	6-9
	Electrical Components .....	6-11
	Rear Battery Compartment, E10M .....	6-13
	Rear Battery Compartment, E8M .....	6-15
	Undercarriage Components, E8M AA - CA, E10M AA - CA .....	6-17
	Undercarriage Components, E8DA, EA, E10DA .....	6-19
	Drive Assembly .....	6-21
6A	E16 Tractor Parts .....	6A-1
	Body Components .....	6A-3
	Dash Components .....	6A-5
	Electrical Components .....	6A-7
	Speed Control .....	6A-9

CONTENTS (Cont'd)

Section	Page
6B E14 Tractor Parts . . . . .	6B-1
Body Components . . . . .	6B-3
Dash Components . . . . .	6B-5
Electrical Components, E14RC, RD, RH . . . . .	6B-7
Electrical Components, E14AA, RJ . . . . .	6B-9
Speed Control . . . . .	6B-11
6C ER8-36 Rider Parts . . . . .	6C-1
Body Assembly . . . . .	6C-5
Chassis Assembly . . . . .	6C-10
Control Panel Assembly . . . . .	6C-13
6D I-5 Tractor Parts . . . . .	6D-1
Body Components . . . . .	6D-3
Dash Components, I-5AA, BA . . . . .	6D-5
Dash Components, I-5CA . . . . .	6D-7
Electrical Components, I-5AA, BA . . . . .	6D-9
Electrical Components, I-5CA . . . . .	6D-11
Speed Control . . . . .	6D-13
7 Rear Battery Compartment . . . . .	7-1
Rear Battery Compartment, Large Frame . . . . .	7-3
8 Chargers . . . . .	8-1
Charger for E20, I-5, E16, E15, E14, E12s, E12, E12M . . . . .	8-3
Charger for ER8, E8M, and E10M . . . . .	8-5
9 Lifts . . . . .	9-1
Front Lift, E20, I-5, E16, E15, E14, E12s, E12 . . . . .	9-3
Lift, E12M . . . . .	9-5
Lift, E8M and E10M . . . . .	9-7
10 Brakes . . . . .	10-1
Brake, Models E20 AA-DA, E15 AA-GA, E12 AA-BA, E12 CA-HA . . . . .	10-3
Brake, Models E20, I-5, E16, E15, E14, E12 . . . . .	10-5
Brake, E12M . . . . .	10-7
Brake, Models E8M and E10M . . . . .	10-9
11 Mower Parts . . . . .	11-1
Rotary Mower Assembly, 42-Inch . . . . .	11-3
Rotary Mower Rear Discharge Assembly . . . . .	11-7
Rotary Mower Side Discharge Assembly . . . . .	11-9
E12M Mid-Mount Rotary Mower . . . . .	11-11
E8M and E10 Mid-Mount Rotary Mower . . . . .	11-13
ER8-36 Mower Assembly . . . . .	11-15
Elec-Trak Lawnmower, Walk Behind . . . . .	11-17
Front Mounted 56-Inch Gang Mower . . . . .	11-19
Sickle Bar Mower, Drive System . . . . .	11-21
Sickle Bar Mower . . . . .	11-25
Mower Parts . . . . .	11-28
12 Misc. & Hardware . . . . .	12-1
13 Steering . . . . .	13-1
Large Frame Steering . . . . .	13-3
Small Frame Steering . . . . .	13-5

CONTENTS (Cont'd)

Section		Page
14	Undercarriage .....	14-1
	Large Frame Undercarriage .....	14-1
	Undercarriage Components .....	14-3
	I-5 Undercarriage Components .....	14-7
15	Front Battery Compartment .....	15-1
	Front Battery Compartment, Large Frame .....	15-1
	Front Battery Compartment .....	15-3
	I-5 Front Battery Compartment .....	15-5
16	Accessories .....	16-1
	AB42 42-Inch Snow/Dozer Blade .....	16-27
	AB48 48-Inch Snow/Dozer Blade .....	16-11
	AD38AA 38-Inch Snow Thrower, Model AD38AA .....	16-19
	AD42AA 42-Inch Snow Thrower, Model AD42AA .....	16-13
	AD42BA, CA 42-Inch Snow Thrower, Model AD42BA, AD42CA .....	16-17
	AF12 12 Cubic Foot Dump Cart .....	16-47
	AG54 Enclosed Cab .....	16-91
	AG55 Enclosed Cab .....	16-48
	AG56 Cab .....	16-29
	AL40 Bucket Loader .....	16-123
	AP50 Sleeve Hitch .....	16-115
	AP54 Implement Mounting Bracket .....	16-81
	AP55 Implement Mounting Bracket and Lift Bracket .....	16-83
	AP58 Manual Lift .....	16-111
	AP59 Rear Electric Lift .....	16-113
	AP69 Horn Kit .....	16-71
	AP70 Rear Tail Light Kit .....	16-69
	AP71 Headlight Kit .....	16-95
	AP72 Auxiliary Light .....	16-97
	AP84 Power Pack Booster .....	16-109
	AP85 Weight Box .....	16-103
	AP86 Weight Box .....	16-105
	AP85/ AP86 Dual Use Weight Box .....	16-73
	AP90 Welder .....	16-33
	AS31 Trailing Lawn Sweeper .....	16-23
	BC11 Canopy Top .....	16-49
	BD22 Double Seat .....	16-49
	BG33 Golf Bag Holder .....	16-49
	BV48 48-Inch V-Plow .....	16-41
	CE12 Rotary Inverter .....	16-9
	CF20 Maintenance Cart .....	16-121
	CF48, CF74, CF92 Fork Lift .....	16-3
	CF66 Overhead Guard .....	16-31
	CH11 Spring Pin Hitch .....	16-101
	CP20 Pallet Handler .....	16-99
	CV60 Vacuum .....	16-39
	CV70 Vacuum .....	16-119
	HC05 Weeder-Cultivator .....	16-57
	HE06 Lawn Edger/Trimmer .....	16-61
	HS13 Chain Saw .....	16-65
	KB48 Dozer Blade Kit .....	16-87
	KB84 Dozer Blade Adapter .....	16-89

CONTENTS (Cont'd)

Section		Page
16	Accessories (Cont'd)	
	KD10 PTO Kit . . . . .	16-107
	KD38 Speed Reduction Kit . . . . .	16-79
	KD42 Snow Thrower Adapter . . . . .	16-85
	KM10 Sweepster Electrification Kit . . . . .	16-117
	KM12 Heavy-duty Transaxle Kit . . . . .	16-77
	KS30 Gauge Shoe Kit . . . . .	16-41
	KS31, KS33 Lawnsweeper Motor Kit. . . . .	16-37
	KS70 Heavy-duty Spindle Kit . . . . .	16-75
	KT25 E8M Heavy Duty Kit . . . . .	16-93
	TH70 Hedge Trimmer Head . . . . .	16-55
	TH80 Grass Trimmer Head . . . . .	16-53
	TM3 Power Unit . . . . .	16-51
	VV100 Rotary Tiller. . . . .	16-43
	VV101 Tiller Mounting Bracket . . . . .	16-45
	GE Housewares Service Centers . . . . .	16-125
17	Motors . . . . .	17-1
	Mower Motors . . . . .	17-2
	E8, E10, E12 Drive Motors . . . . .	17-5
	Drive Motor, E12 and E12M . . . . .	17-7
	Accessory Motors . . . . .	17-9
	Fork Lift Motor . . . . .	17-11
	Motor Identification . . . . .	17-12
18	Terminals . . . . .	18-1
	Ring Terminals . . . . .	18-2
	Faston Terminals . . . . .	18-2
	Shur-Plug Terminals . . . . .	18-2
	Pin, Socket Contacts . . . . .	18-2
	Splices . . . . .	18-3
	Pin and Socket Housings . . . . .	18-3
19	Cross-Reference . . . . .	19-1
	Dash Harness . . . . .	19-2
	Grill Harness . . . . .	19-3
	Undercarriage Harness . . . . .	19-4
	Throttle Harness . . . . .	19-5
	Control Panel Harness . . . . .	19-6
	Installation and Operating Instructions . . . . .	19-7
20	Price List	



TABLE OF CONTENTS



<u>FIGURE</u>	<u>TITLE</u>
E20-1	Body Components
E20-2	Dash Components
E20-3	Dash Components, E20EA
E20-4	Electrical Components
E20-5	Electrical Components, E20EA
E20-6	Speed Controls

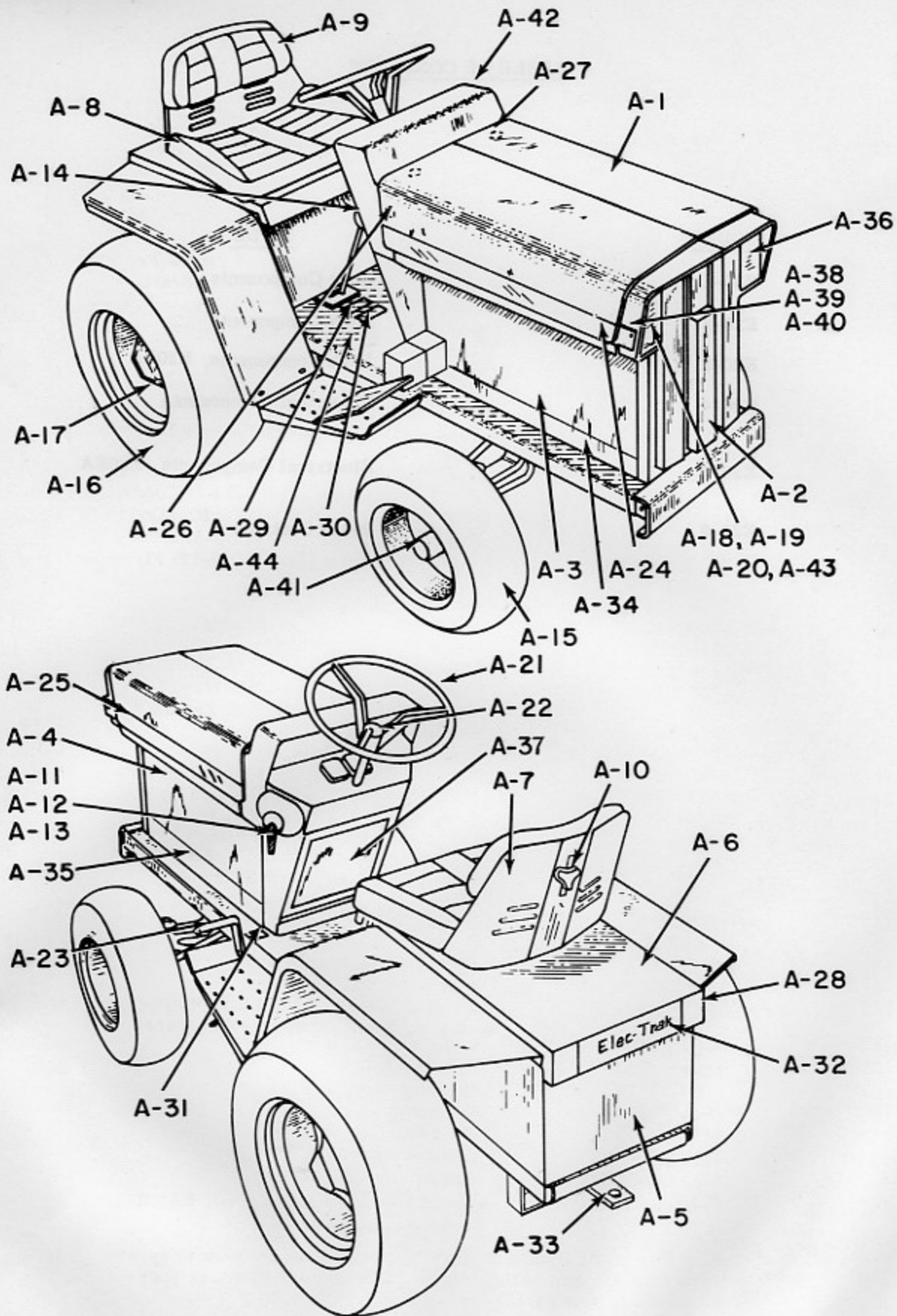

Fig. E20-1

## BODY COMPONENTS

<u>Ref. No.</u>	<u>Part No.</u>	<u>Description</u>
A-1	178B8492G1	Hood Assembly
A-2	423D214P2	Front Grill
A-3	422D837P3	Side Body Panel, Right
A-4	422D838P3	Side Body Panel, Left
A-5	423D221G3	Rear Battery Box Assy. (Includes Fenders)
A-6	541C937G8	Rear Battery Box Cover (Less Seat)
A-7	247A7412G1	Seat (Formed)
A-7	243A4799P1	Seat Pan
A-8	178B8003P1	Cushion, Bottom
A-9	243A4800P1	Cushion, Rear
A-10	243A4801P1	Rear Seat Knob
A-11	178B8137G1	Power Disconnect
A-12	211A3448G1	Fusible Link (Located on Power Disconnect)
A-13	243A4502P1	Power Disconnect Knob
A-14	211A3249P3	Gear Shift Knob
A-15*	191B4507G1	Front Tire & Rim (16 x 6.50-8) Goodyear
A-16*	243A4857G2	Rear Tire (23 x 10.50-12) & Rim Goodyear
A-15	163B9707G1	Front Tire & Rim (16 x 6.50-8)
A-16	243A4857G1	Rear Tire & Rim (23 x 10.50-12) Firestone
A-17	243A4589P1	Wheel Lug
A-18	211A3413P1	Headlight Lens
A-19	163B9936G1	Reflector and Light Assembly
A-20	211A3592P1	Lamp (GE 1076)
A-21	423D255P1	Steering Wheel
A-22	243A4828G1	Cap and Monogram Assembly
A-23		Brake Pedal Assembly (See Section N)
A-24	127D8094P3	Hood Decal, Right Hand
A-25	127D8094P4	Hood Decal, Left Hand
A-26	243A4639P1	Hood Rubber Bumper (Mounted on Both Sides)
A-27	243A4639P2	Hood Rubber Bumper (Mounted on Top - 2 Req.)
A-28	243A4870P1	Rear Tail Reflector (2 Req.)
A-29	243A4869P1	Decal, "To Facilitate Shifting"
A-29*	247A7473P1	Shift Graphics (DA, EA, EC, FA)
A-30	243A4794P1	Decal, "Shift to Lower Gear"
A-31	211A3247P1	Decal, "Parking Brake"
A-32	178B8024P1	Decal, "Elec-Trak"
A-33	163B9919P1	Conv. Hitch
A-34	127D8095P3	Elec Trak Insignia RH
A-35	127D8095P4	Elec Trak Insignia LH
A-36	163B9878G1	Headlight Assembly (Includes Reflector & Light Asm, Lamp, Lens, Hardware and Spacer)
A-37	542C868P2	Cover
A-38	243A4588P1	Machine Screw
A-39	211A3424P1	Bushing
A-40	243A4576P2	Washer
A-41	247A7649P1	Dust Cap
A-42	423D260P2	Control Cabinet
A-43	243A4550P4	Spacer (Headlight)
A-44	247A7802P1	Floor Mat (E20EA, EC, ED, FA, RA)

\*When ordering this item it is imperative that care be taken to specify the model number and serial number of the tractor to insure your receiving the proper part.

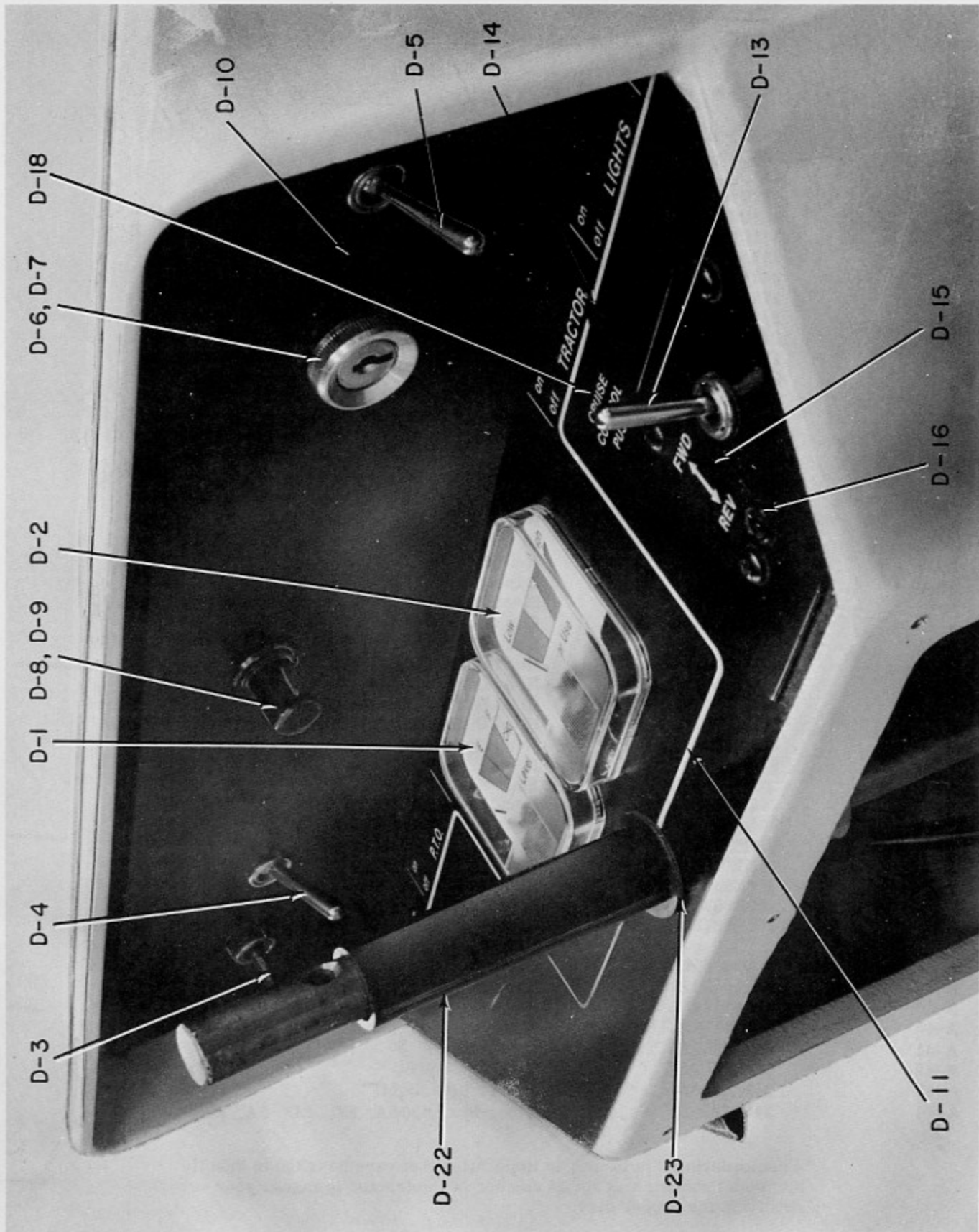

Fig. E20-2

DASH COMPONENTS

<u>Ref. No.</u>	<u>Part No.</u>	<u>Description</u>
D-1	243A4629G1	Fuel Level Gauge
D-2	243A4630G4	Power Use Gauge
D-3	243A4531P2	Lift Switch
D-4	243A4531P1	P. T. O. Switch
D-5	243A4531P3	Light Switch
D-6	243A4573P1	Key Switch
D-7	211A3597P1	Key
D-8	243A4574P1	Light, Dash
D-9	211A3591P1	Lamp (GE 1815)
D-10	163B9821P1	Dash Panel
D-11	541C681P1	Decal, Dash
D-12	541C994G1	Dash Harness
D-13	243A4814P1	F-R Switch
D-14	243A4848P1	Cruise Control Switch
D-15	243A4815P2	Decal (F-R)
D-16	243A4979P1	Reverse Light (Replaces 243A4941P1)
D-17	178B8095G1	Cruise Control Harness (Not Pictured)
D-18	243A4815P1	Decal (Cruise Control)
D-19	211A3551P1	Tubing (Not Pictured - Insulation for Switch Terminals)
D-20	127D8106P1	Dash Panel (Requires REF D-21)
D-21	247A7469P1	Plug, Switch
D-22*	243A4809P1	Sleeve (AA, BA, CA, only)
D-23	243A4576P3	Washer (AA, BA, CA, DA only)
D-22*	243A4809P2	Sleeve (DA)

\*When ordering this item it is imperative that care be taken to specify the model number and serial number of the tractor to insure your receiving the proper part.

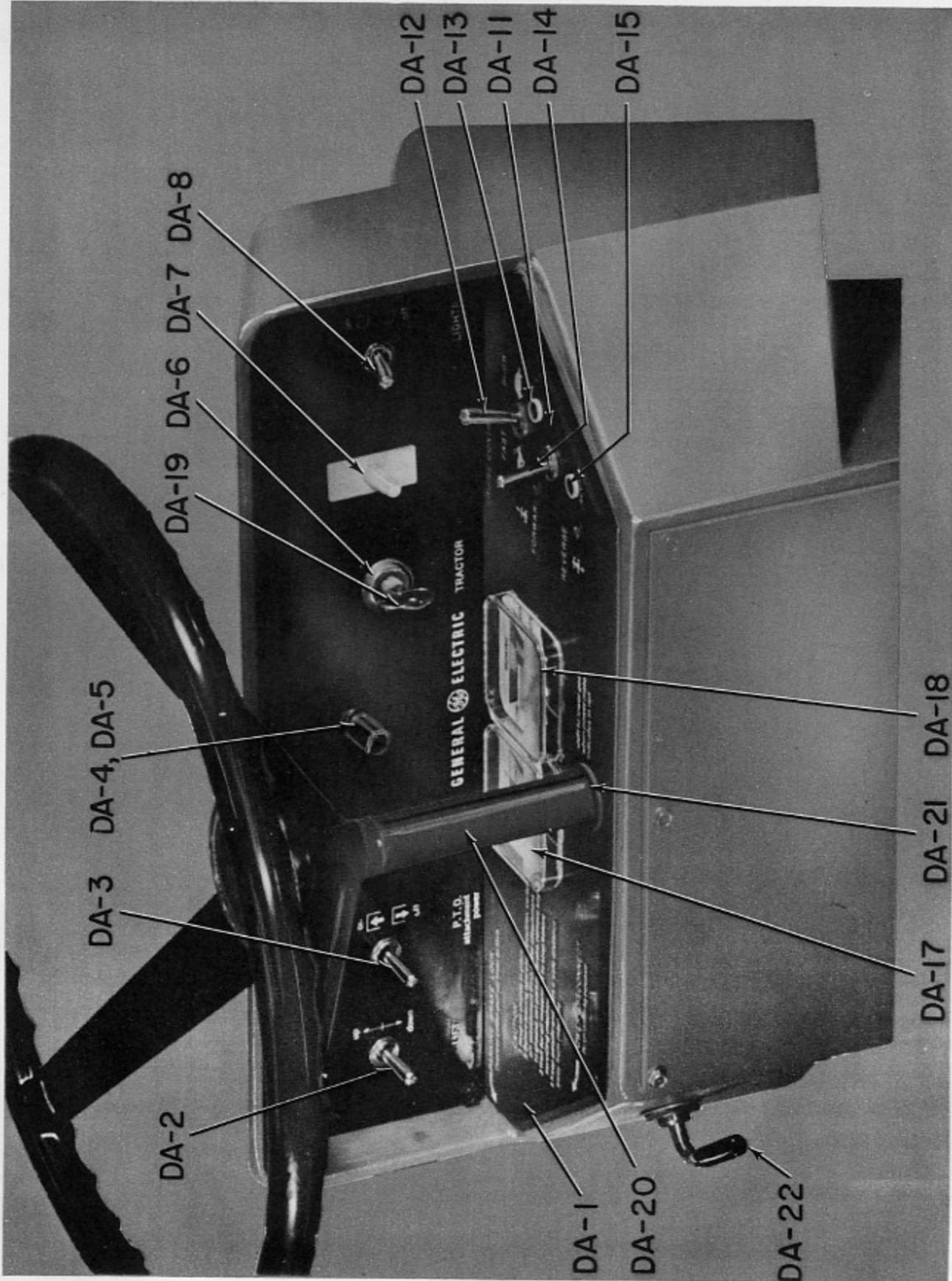

Fig. E20-3

DASH COMPONENTS

<u>Ref. No.</u>	<u>Part No.</u>	<u>Description</u>
DA-1	127D8106P2	Dash Panel
DA-2	243A4531P2	Lift Switch
DA-3	244A7229P1	P. T. O. Switch
DA-4	243A4574P1	Light, Dash
DA-5	211A3591P1	Lamp (GE 1815)
DA-6	244A7308P1	Key Switch
DA-7	247A7455P1	Cruise Control Button (Switch)
DA-8	243A4531P3	Light Switch
DA-9	158C9052G1	Dash Harness
DA-10	211A3551P1	Tubing (Not Pictured - Insulation for Switch Terminals)
DA-11	178B8468P2	Plate, Fwd. - Rev.
DA-12	243A4531P3	Cruise Control Switch
DA-13	247A7474P2	Cruise Control Light
DA-14	243A4814P1	Fwd./Rev. Switch
DA-15	247A7474P1	Reverse Light
DA-16	178B8472G1	F-R Control Harness
DA-17	243A4629G1	Fuel Level Gage
DA-18	243A4630G4	Power Use Gage
DA-19	247A7354P1	Key
DA-20	243A4809P2	Sleeve
DA-21	243A4576P3	Washer
DA-22	244A7089P1	Hand Grip

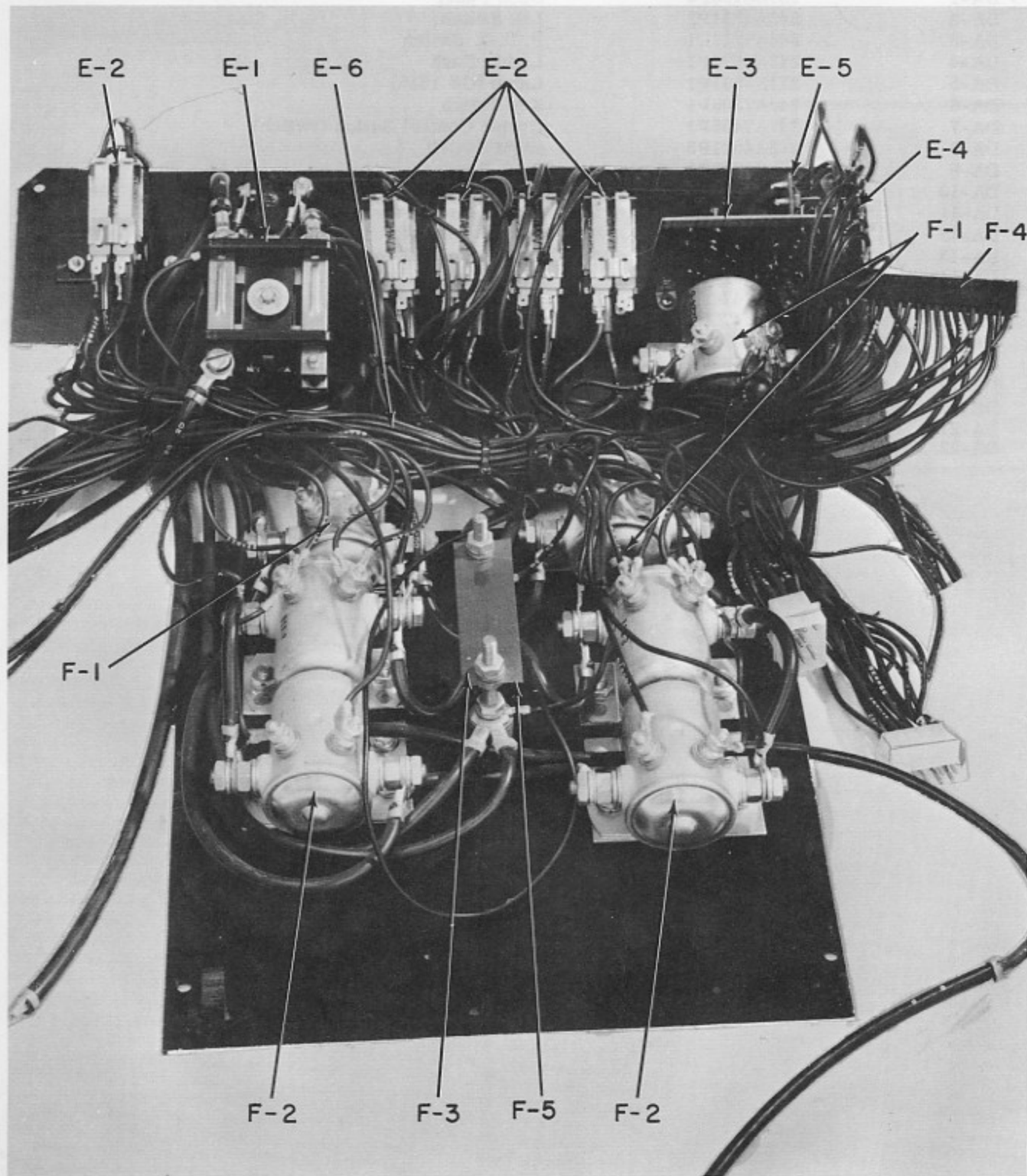

Fig. E20-4

ELECTRICAL COMPONENTS(Upper Control Panel)

<u>Ref. No.</u>	<u>Part No.</u>	<u>Description</u>
E-1	243A4524P1	P. T. O. Contactor
E-2	243A4562P1	Relay
E-3*	178B8107G1	Card #4 (E-20CA, DA)
E-3*	163B9977G1	Card #4 (E-20 AA & BA)
E-4	211A3162G2	Card #3
E-5	243A4940G1	Diode and Resistor Assembly
E-6#	127D8006G1	Control Panel Harness (AA, BA)
E-6#	127D8008G1	Control Panel Harness (CA, CB, CC, DA)

(Lower Control Panel)

<u>Ref. No.</u>	<u>Part No.</u>	<u>Description</u>
F-1	211A3567P1	Contactor
F-2	178B8009P1	Double Contactor
F-3	211A3213P3	Current Sensing Shunt
F-4	178B8013P3	Edge Connector
F-5	247A7693G2	Shunt Kit (Includes 211A3213P3)

#It is imperative that when ordering this part you specify the model number and serial number of the tractor to insure your receiving the proper part.

\*To facilitate manufacturing, the diode and resistor assembly was incorporated in the Card #4 which caused other electrical changes therefore when ordering this part it is imperative you include the model number and serial number to insure your receiving the proper part.

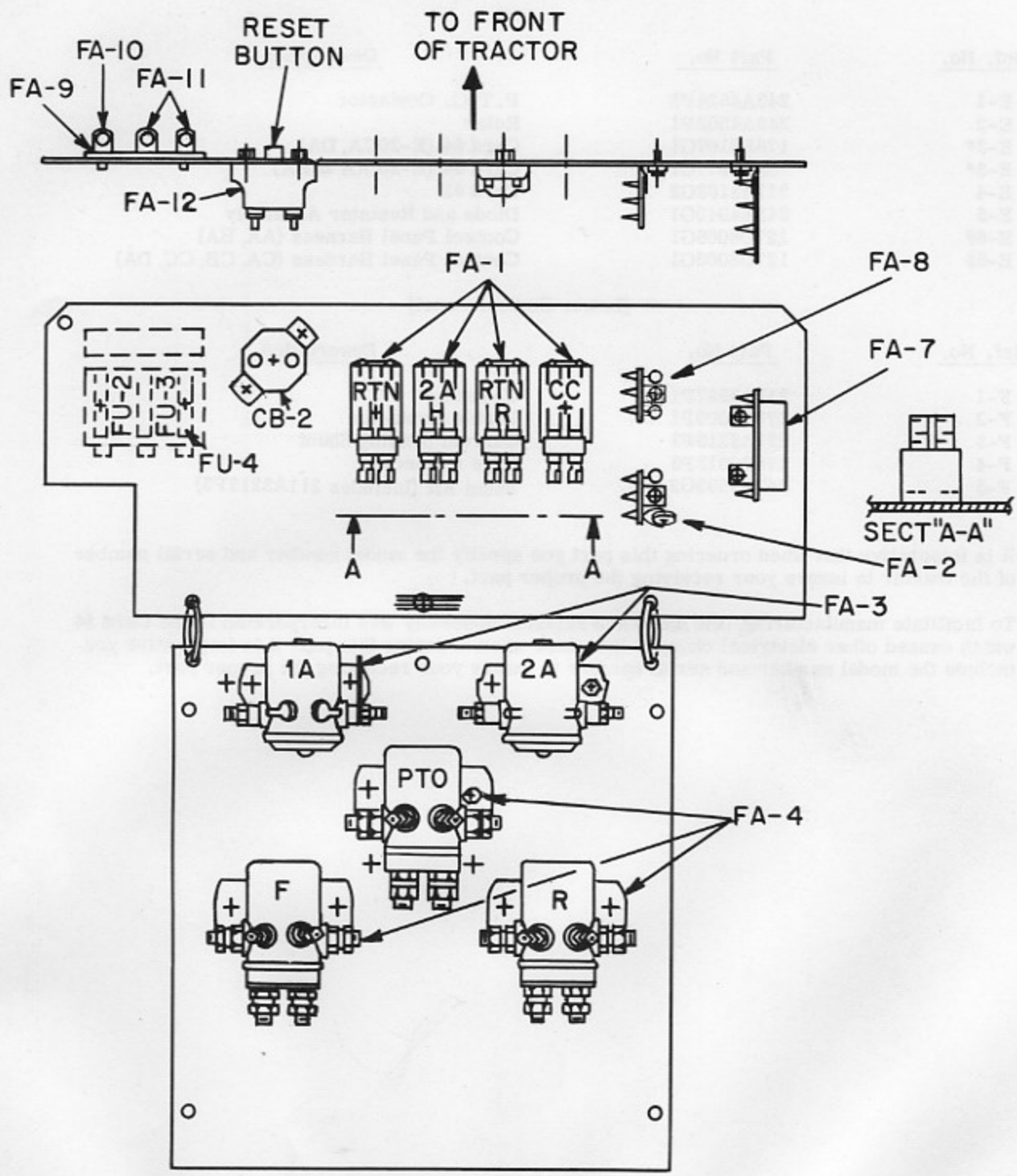

Fig. E20-5

ELECTRICAL COMPONENTS

<u>Ref. No.</u>	<u>Part No.</u>	<u>Description</u>
FA-1	243A4562P1	Relay
FA-2	178B8457G1	Diode and Varistor Asm.
FA-3*	211A3567P1	Contactor (1A, 2A) for EA only
FA-4	178B8385P1	Contactor (P. T. O., F, R)
FA-5	127D8112G1	Control Panel Harness (Now Shown)
FA-6	127D8113G1	Control Panel Adder Harness (Not Shown)
FA-7	178B8459G1	Field Resistor Asm.
FA-8	191B4585G1	Diode Asm.
FA-9	244A7463P1	Fuse Block
FA-10	243A4597P1	Fuse 30 Amp
FA-11	243A4657P1	Fuse 20 Amp
FA-12	243A4719P1	Circuit Breaker
FA-3	247A7462P1	Contactor (EC, ED, FA, RA)

\*When ordering this item it is imperative that care be taken to specify the model number and serial number of the tractor to insure your receiving the proper part.

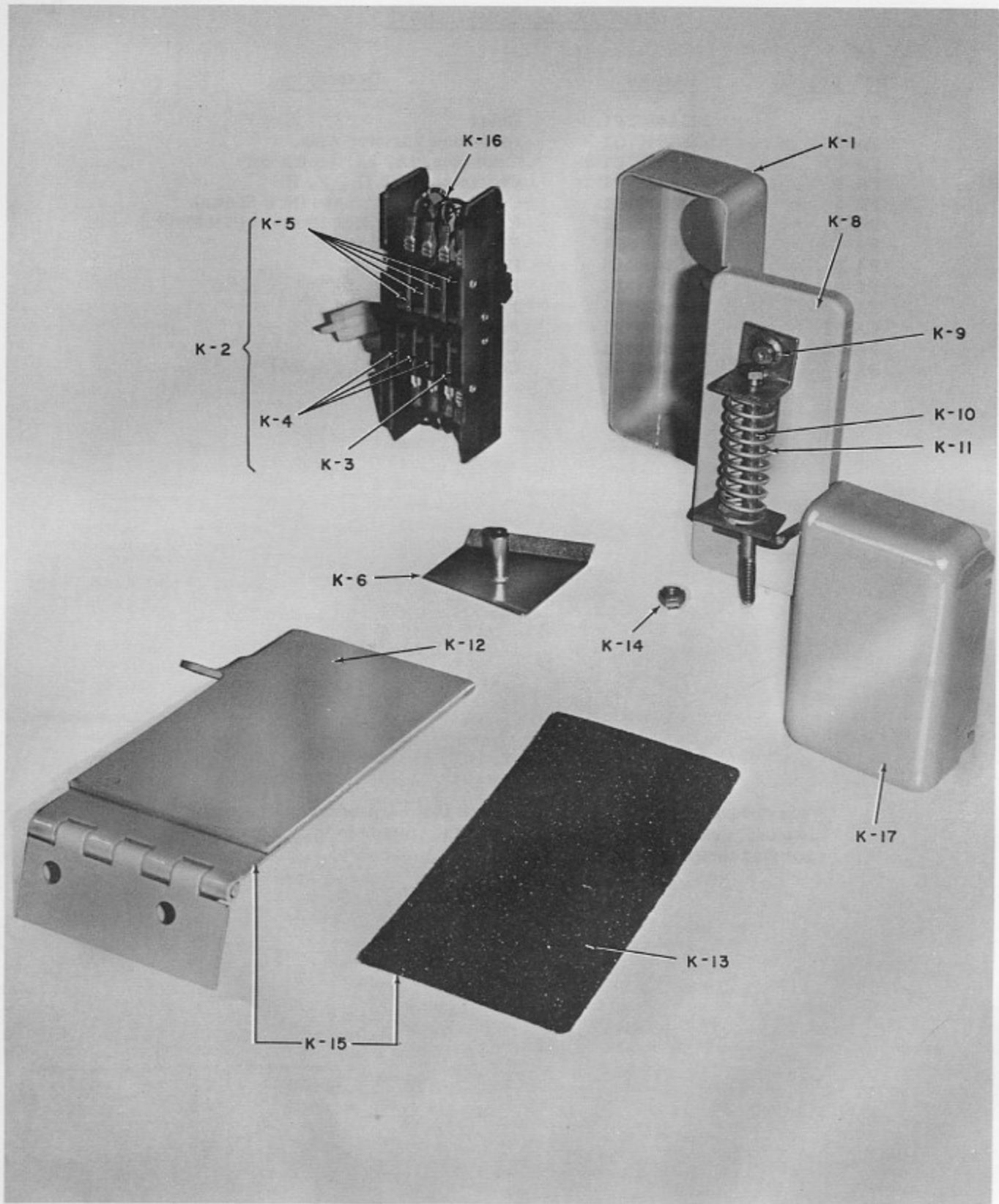

Fig. E20-6

SPEED CONTROL

<u>Ref. No.</u>	<u>Part No.</u>	<u>Description</u>
K-1	163B9997P1	Throttle Box
K-2*	178B8250G1	Rail & Switch Asm Less Harness (AA, BA, CA, CB, CC, DA)
K-2*	178B8250G2	Rail & Switch Asm Less Harness (EA, EC, ED, FA, RA)
K-3	211A3198P1	Start Switch, 3 Tabs
K-4*	211A3198P2	1A, 2A, 3A Switch, 2 Tabs, N.O. & Common (AA, BA, CA, CB, CC, DA)
K-4*	211A3198P2	1A, 2A Switch, 2 Tabs N.O. & Common (EA, EC, ED, FA, RA)
K-5*	211A3198P3	FW 1-4 Switch, 2 Tabs, N.C. & Common (AA, BA, CA, CB, CC, DA)
K-5*	211A3198P3	FW 1-4 Switch, Switch 4, 2 Tabs, N.C. & Common (EA, EC, ED, FA, RA)
K-6	243A4796G1	Throttle Cam
K-7	211A3577P3	Spring (Not Shown)
K-8	178B8249G1	Cover & Bracket Asm
K-9	243A4554P1	Push Nut
K-10	N22P21072B6	Screw (1/4 - 20 x 4 1/2")
K-11	211A3577P12	Spring
K-12 *	191B4516G1	Throttle Pedal (Hinged)(Replaces 178B8001P1)
K-13	243A4825P2	Throttle Pedal Pad (Replaces 243A4825P1)
K-14	N264P21B6	Locknut (1/4-20)
K-15	247A7620G1	Pedal Assembly (K-12 and K-13)
K-16 *	178B8097G1	Harness, Throttle (AA, BA, CA, CB, CC, DA)
K-16 *	178B8480G1	Harness, Throttle (EA, EC, ED, FA, RA)
K-17	163B9999P1	Cover
K-18§	158C9071G4	Complete Throttle (AA through DA)
K-18§	158C9071G1	Complete Throttle (EA through RA)

\*When ordering this item it is imperative that care be taken to specify the model number and serial number of the tractor to insure your receiving the proper part.

§ Includes all items shown on page 1-12.

E15

## TABLE OF CONTENTS

<u>FIGURE</u>	<u>TITLE</u>
E15-1	Body Components
E15-2	Dash Components
E15-3	Dash Components, E15HA
E15-4	Electrical Components (Upper Control Panel)
E15-5	Electrical Components (Lower Control Panel)
E15-6	Electrical Components, E15HA
E15-7	Speed Controls

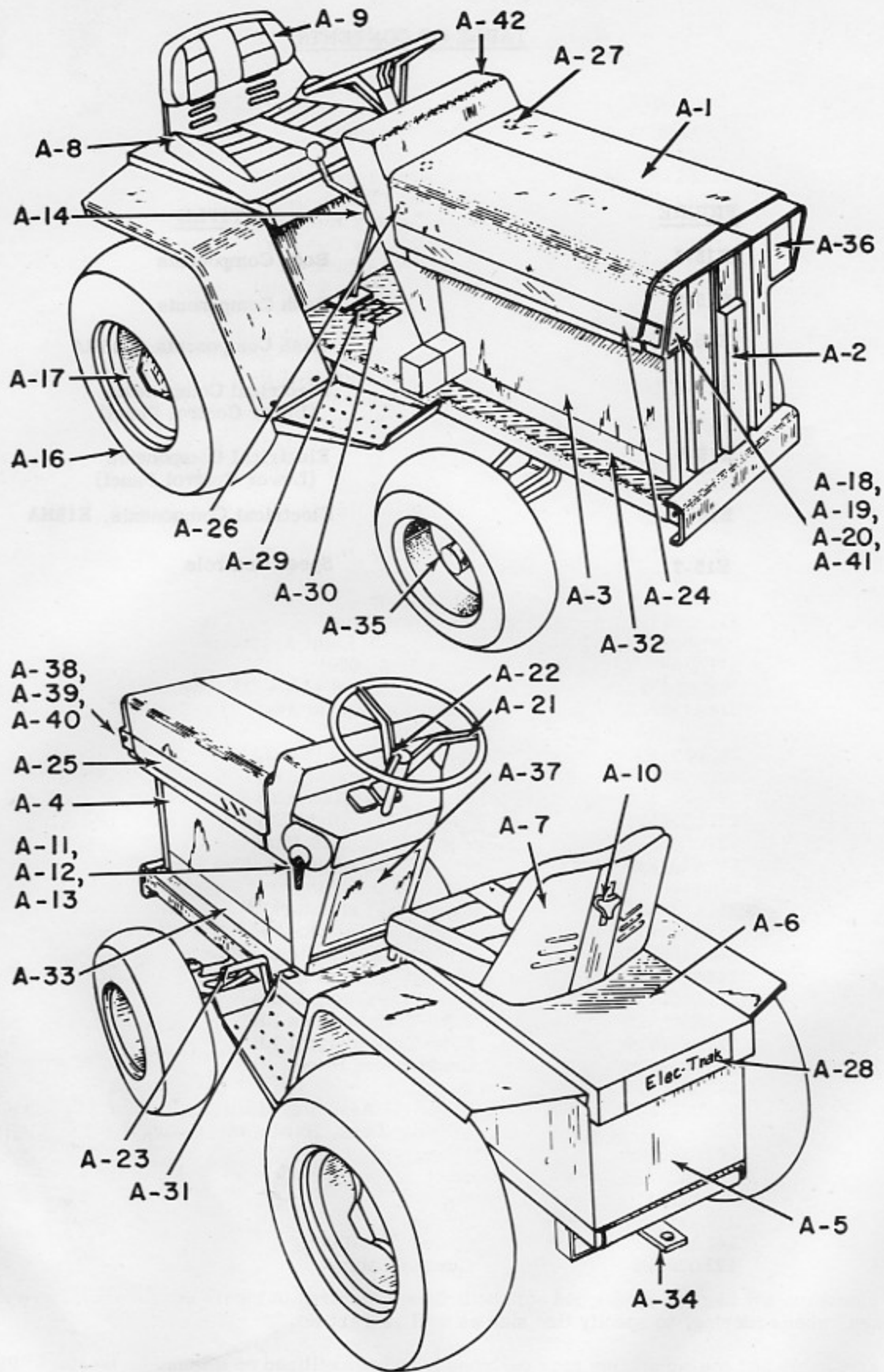

Fig. E15-1

BODY COMPONENTS

<u>Ref. No.</u>	<u>Part No.</u>	<u>Description</u>
A-1	178B8492G1	Hood Assembly
A-2	423D214P2	Front Grill
A-3	422D837P3	Side Body Panel, Right
A-4	422D838P3	Side Body Panel, Left
A-5	423D221G3	Rear Battery Box Assy. (Includes Fenders)
A-6	541C937G8	Rear Battery Box Cover (Less Seat)
A-7#	243A4799P1	Seat Pan (Adjustable Back)
A-7#	243A4770P1	Seat Pan (Non-Adjustable Back)
A-8	178B8030P1	Cushion, Bottom
A-9#	243A4800P1	Cushion, Rear (Adjustable)
A-9#	243A4852P1	Cushion, Rear (Non-Adjustable)
A-10	243A4801P1	Rear Seat Knob (Not Required with A-9 Non-Adjustable Rear Cushion)
A-11	178B8137G1	Power Disconnect
A-12	211A3448G1	Fusible Link (Located on Power Disconnect)
A-13	243A4502P1	Power Disconnect Knob
A-14	211A3249P3	Gearshift Knob
A-15*	541C951G1	Front Tire (16 x 4.80/4.00-8) & Rim (CB, DA, EA, CA, GA, HA)
A-15*	163B9707G1	Front Tire (16 x 6.50-8) & Rim (AA, BA, CA only)
A-16	541C658G2	Rear Tire (23 x 9.50-12) & Rim
A-17	243A4589P1	Wheel Lug
A-18	211A3413P1	Headlight Lens
A-19	163B9936G1	Reflector & Light Assembly
A-20	211A3592P1	Lamp (GE 1076)
A-21+	163B9843P1	Steering Wheel (AA - DA Models)
A-22	243A4853G1	Cap & Monogram Assy. (Used with Steering Wheel Above)
A-21A+	423D255P1	Steering Wheel (EA-JA)
A-22A	243A4828G1	Cap & Monogram Assy. (Used with Above)
A-23		Brake Pedal Assembly (See Section N)
A-24	127D8093P3	Hood Decal, Right Hand
A-25	127D8093P4	Hood Decal, Left Hand
A-26	243A4639P1	Hood Rubber Bumper (Mounted on Both Sides)
A-27	243A4639P2	Hood Rubber Bumper (Mounted on Top)
A-28	211A3250P1	Rear Tail Reflector
A-29	247A7473P1	Decal, "To Facilitate Shifting" (Plastic)
A-29*	243A4869P1	Decal, "To Facilitate Shifting"
A-30	243A4794P1	Decal, "Shift to Lower Gear"
A-31	211A3247P1	Decal, "Parking Brake"
A-32	127D8095P3	Elec-Trak Insignia RH
A-33	127D8095P4	Elec-Trak Insignia LH
A-34	163B9919P1	Convenience Hitch
A-35	247A7649P1	Dust Cap
A-36	163B9878G1	Headlight Assembly (includes Reflector & Light Asm, Lamp, Lens, Hardware & Spacer)
A-37	542C868P2	Cover
A-38	243A4588P1	Machine Screw
A-39	211A3424P1	Bushing
A-40	243A4576P2	Washer
A-41	243A4550P4	Spacer (Headlight)
A-42	423D260P5	Control Cabinet

\*This model tractor has come equipped with both these size tires to insure consistency, care should be taken, when ordering, to specify tire size as well as Part No.

#Both adjustable and non-adjustable rear cushions have been utilized on this model tractor. Please take care to note which one you have when ordering replacement parts.

+This model tractor is equipped with both 12 7/8 dia. steering wheel (A-21) and 14 7/8 dia. steering wheel (A-21A). Please take care to note which one you have when ordering replacement parts.

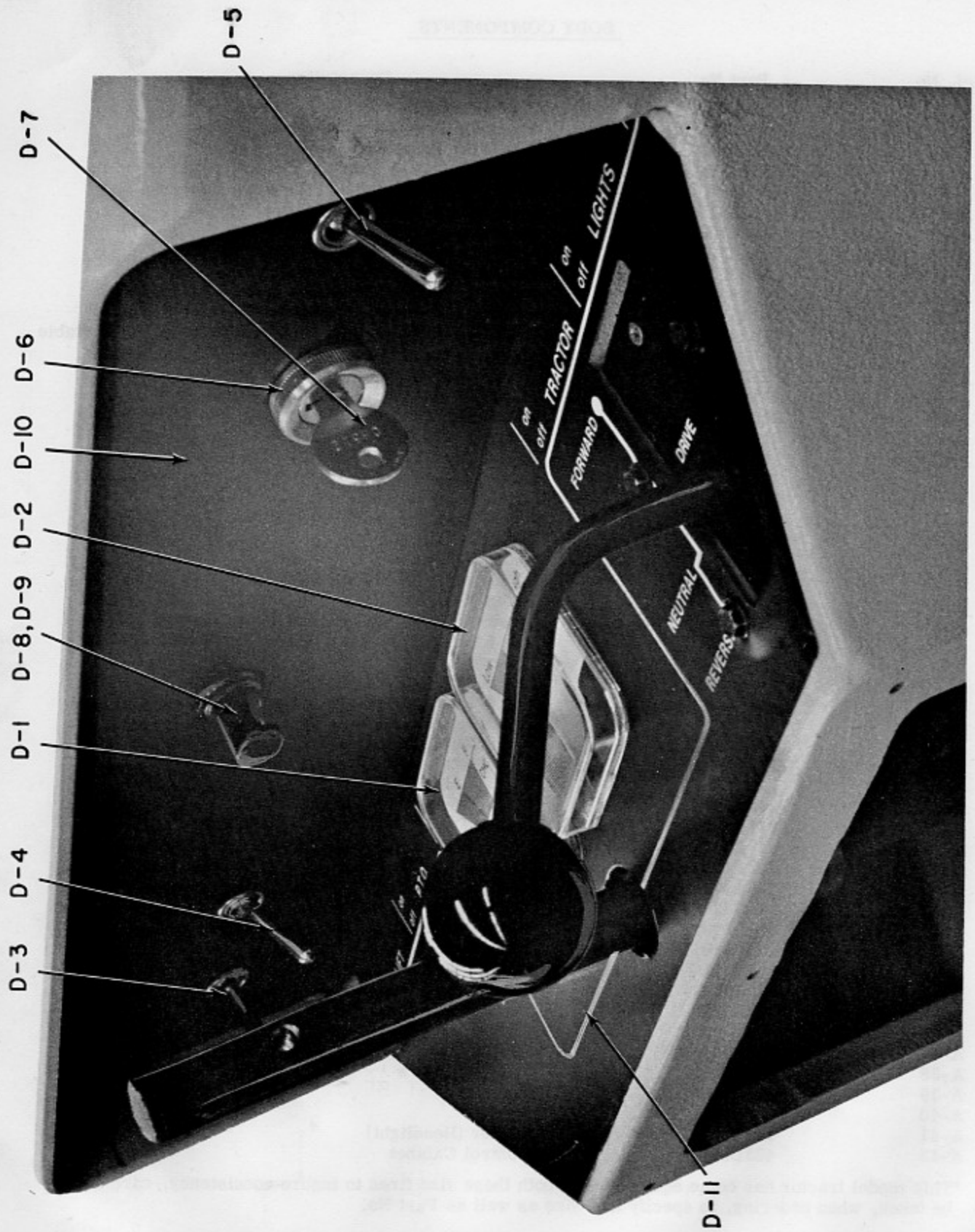

Fig. E15-2

DASH COMPONENTS

<u>REF. NO.</u>	<u>PART NO.</u>	<u>DESCRIPTION</u>
D-1	243A4629G1	FUEL LEVEL GAUGE
D-2	243A4630G4	POWER USE GAUGE
D-3	243A4531P2	LIFT SWITCH
D-4	243A4531P1	P.T.O. SWITCH
D-5	243A4531P3	LIGHT SWITCH
D-6	243A4573P1	KEY SWITCH
D-7	211A3597P1	KEY
D-8	243A4574P1	LIGHT, DASH
D-9	211A3591P1	LAMP (GE 1815)
D-10	163B9821P1	DASH PANEL
D-11	541C681P1	DECAL, DASH
D-12*	541C920G1	DASH HARNESS (E-15AA)
D-13*	541C955G1	DASH HARNESS (E15BA, CA, CB, DA & EA)
D-14	211A3551P1	TUBING (NOT PICTURED—INSULATION ON SWITCH TERMINALS)

\*IT IS IMPERATIVE THAT WHEN ORDERING THIS PART, THE MODEL NUMBER AND SERIAL NUMBER OF THE TRACTOR MUST BE STATED TO INSURE YOUR RECEIVING THE PROPER PART.

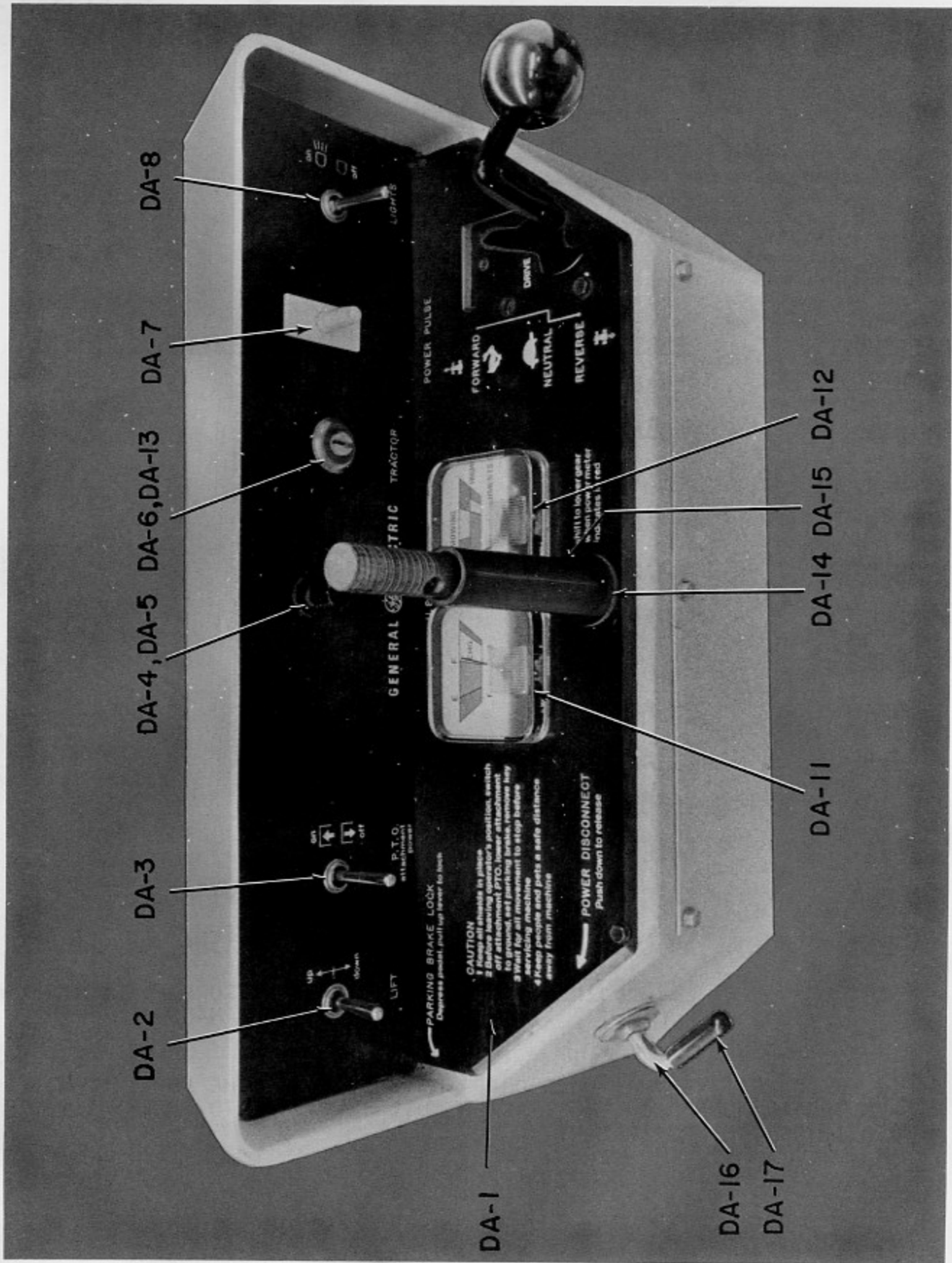

Fig. E15-3

DASH COMPONENTS

<u>Ref. No.</u>	<u>Part No.</u>	<u>Description</u>
DA-1	127D8106P2	Dash Panel
DA-2	243A4531P2	Lift Switch
DA-3	244A7229P1	P. T. O. Switch
DA-4	243A4574P1	Light, Dash
DA-5	211A3591P1	Lamp
DA-6	244A7308P1	Key Switch
DA-7	247A7455P1	Power Pulse Switch
DA-8	243A4531P3	Light Switch
DA-9	158C9052G1	Dash Harness
DA-10	211A3551P1	Tubing (Not Pictured - Insulation on Switch Terminal)
DA-11	243A4629G1	Fuel Level Gage
DA-12	243A4630G4	Power Use Gage
DA-13	247A7354P1	Key
DA-14	243A4576P3	Washer
DA-15	243A4809P2	Sleeve
DA-16	178B8137G1	Power Disconnect (Includes Hand Grip)
DA-17	244A7089P1	Hand Grip

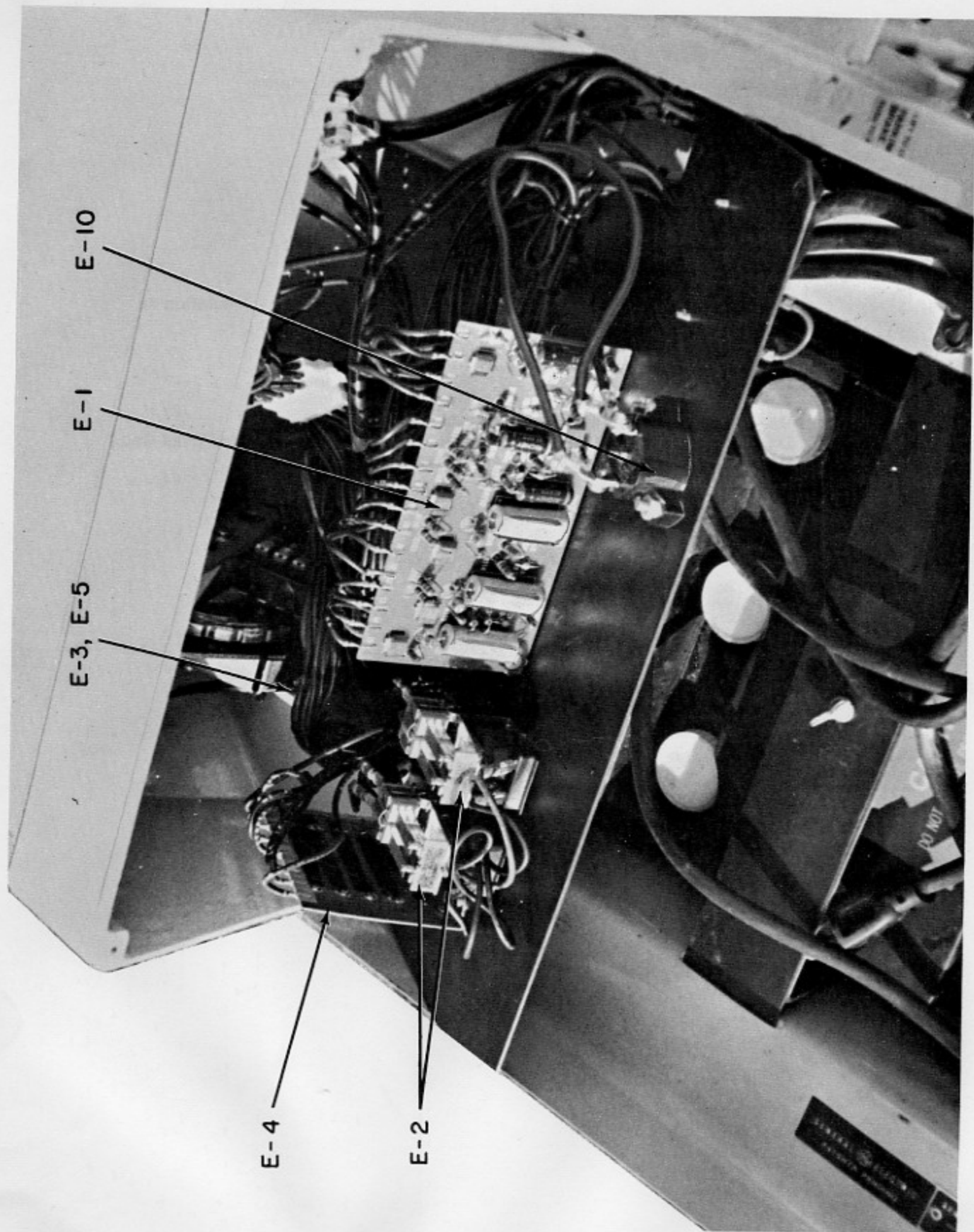

Fig. E15-4

ELECTRICAL COMPONENTS

(Upper Control Panel)

<u>Ref. No.</u>	<u>Part No.</u>	<u>Description</u>
E-1	163B9814G1	Card #1
E-2	243A4562P1	Relay
E-3*	423D216G1	Control Panel Harness (E-15AA)
E-3*	423D245G1	Control Panel Harness (E-15CA, DA)
E-3*	423D236G1	Control Panel Harness (E-15BA)
E-4	211A3162G1	Card #3
E-5	127D8012G1	Control Panel Harness (E-15EA, FA, GA)
E-6*	243A4591P1	Fuse Board (AA, BA, CA, DA)
E-6*	243A4807P1	Fuse Board (EA, FA)
E-7	211A3528P1	Fuse Decal
E-8	243A4657P1	Fuse-20 Amp, FU3, FU4
E-9	243A4597P1	Fuse-30 Amp, Slo Blo, FU2
E-10	243A4719P1	Circuit Breaker (Manual Reset)

\*When ordering this item it is imperative that care be taken to specify the model number and serial number of the tractor.

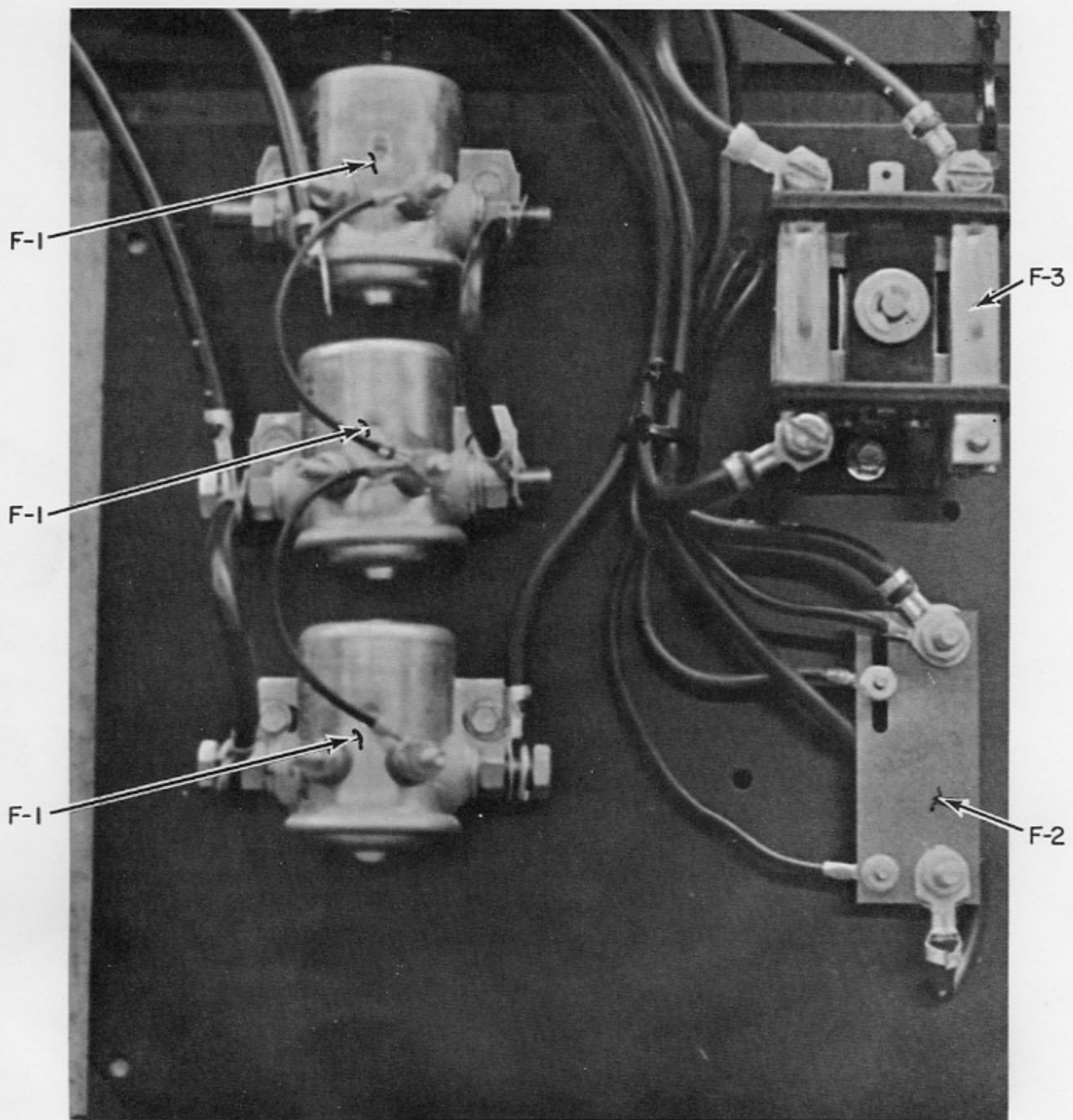

Fig. E15-5

ELECTRICAL COMPONENTS  
(Lower Control Panel)

<u>Ref. No.</u>	<u>Part No.</u>	<u>Description</u>
F-1	211A3567P1	Contactor
F-2	211A3164G1	Meter Shunt Assembly
F-3	243A4524P1	PTO Contactor



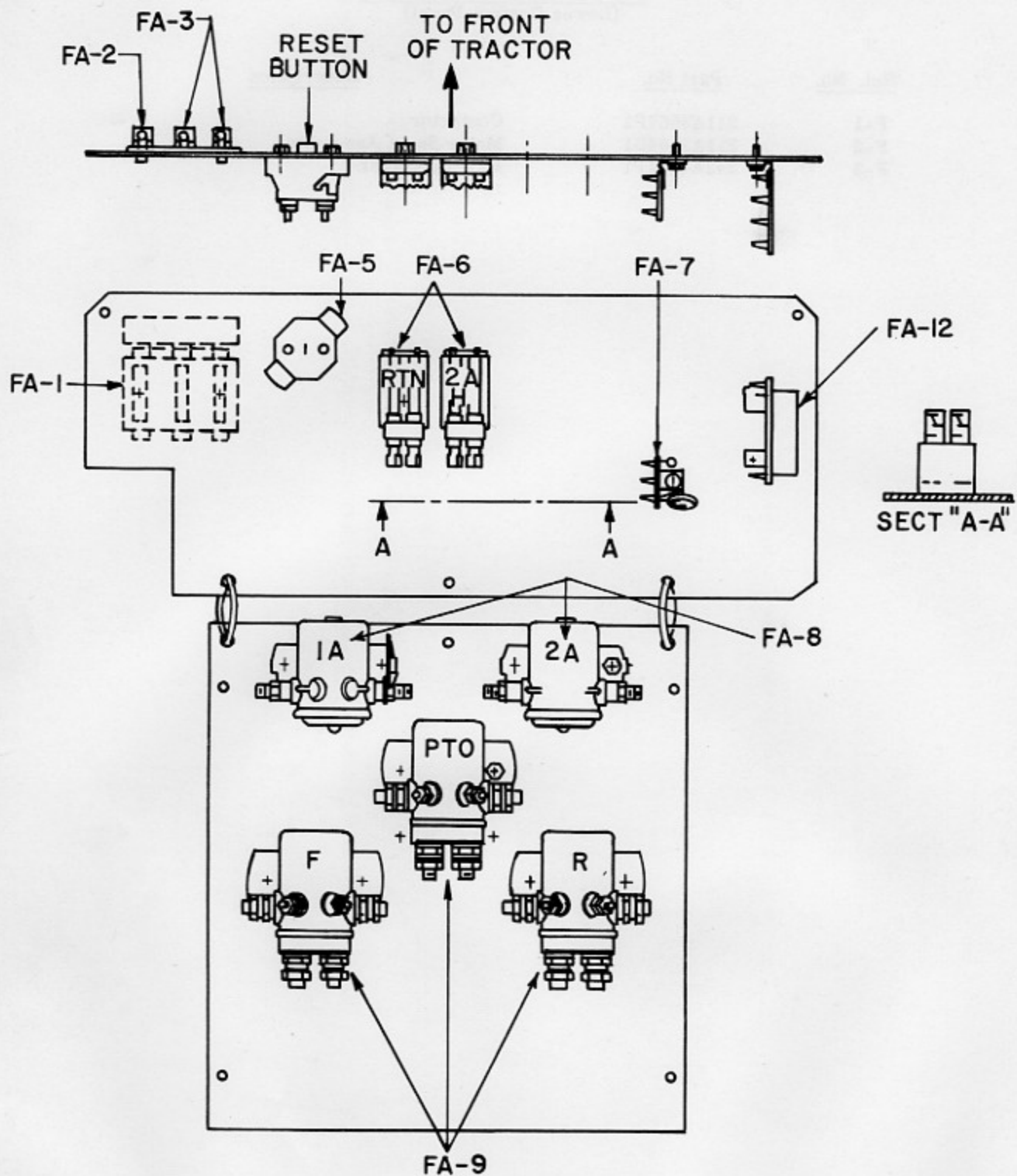

Fig. E15-6

ELECTRICAL COMPONENTS

<u>Ref. No.</u>	<u>Part No.</u>	<u>Description</u>
FA-1	244A7463P1	Fuse Block
FA-2	243A4597P1	Fuse 30 Amp Slo Blo, FU2
FA-3	243A4657P1	Fuse 20 Amp, FU3, FU4
FA-5	243A4719P1	Circuit Breaker (Manual Reset)
FA-6	243A4562P1	Relay (Rtn, 2AH)
FA-7*	178B8457G1	Diode and Varistor Asm. (HA)
FA-8*	211A3567P1	Contactora (1A, 2A) HA
FA-9	178B8385P1	Contactora (P. T. O., F R)
FA-10	127D8112G1	Control Panel Harness (Not Shown)
FA-11	158C9064G2	Control Panel Adder Harness (HA, JA)
FA-12	178B8459G1	Field Resistor Asm.
FA-8	247A7462P1	Contactora (1A-2A) JA
FA-7	178B8457G3	Diode & Varistor Asm (JA)

\*When ordering this item it is imperative that care be taken to specify the model number and serial number of the tractor to insure your receiving the proper part.

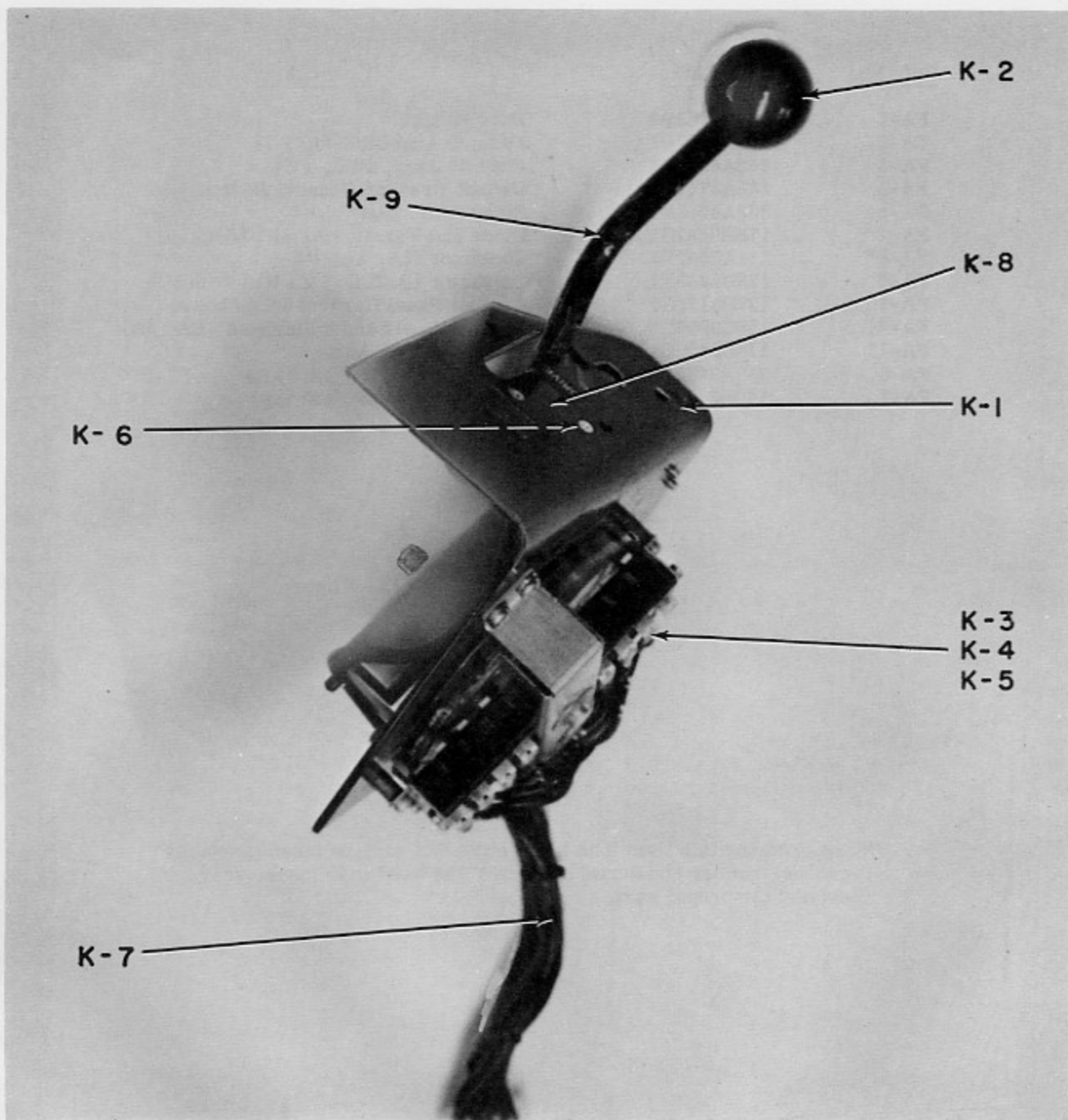

Fig. E15-7

SPEED CONTROL

<u>Ref. No.</u>	<u>Part No.</u>	<u>Description</u>
K-1*	423D213G1	Speed Control (E15AA & CA, CB, DA, EA, FA, & GA)
K-1*	423D213G2	Speed Control (E15BA)
K-1*	423D213G5	Speed Control (E15HA)
K-2	211A3249P1	Speed Control Knob
K-3	211A3198P1	Start Switch, 3 Tabs, N.O. N.C. and Common
K-4	211A3198P2	1A, 2A Switch, 2 Tabs, N.O. and Common
K-5	211A3198P3	FW, 1-4, 2 Tabs, N.C. and Common
K-6	211A3558P1	Reverse Switch
K-7*	541C919G1	Throttle Harness (E15AA, CA, CB, DA, EA, FA & GA)
K-7*	541C957G1	Throttle Harness (E15BA)
K-7*	158C9051G1	Throttle Harness (E15HA)
K-8	211A3449P1	Decal - Drive
K-9	211A3239G1	Lever

\*It is imperative when ordering a speed control or parts, that you specify the model number and serial number of the tractor to insure your receiving the proper part.

NOTE: Roll pin connecting throttle lever to cam shaft must be replaced by clevis pin, Part No. 247A7830P1, and cotter pin, Part No. N503P312 1/32 x 3/4 LG. to improve throttle assembly.

E12s

TABLE OF CONTENTS

<u>Figure</u>	<u>Title</u>
E12S-1	Body Components
E12S-2	Dash Components
E12S-3	Electrical Components (Upper Control Panel)
E12S-4	Electrical Components (Lower Control Panel)
E12S-5	Speed Controls

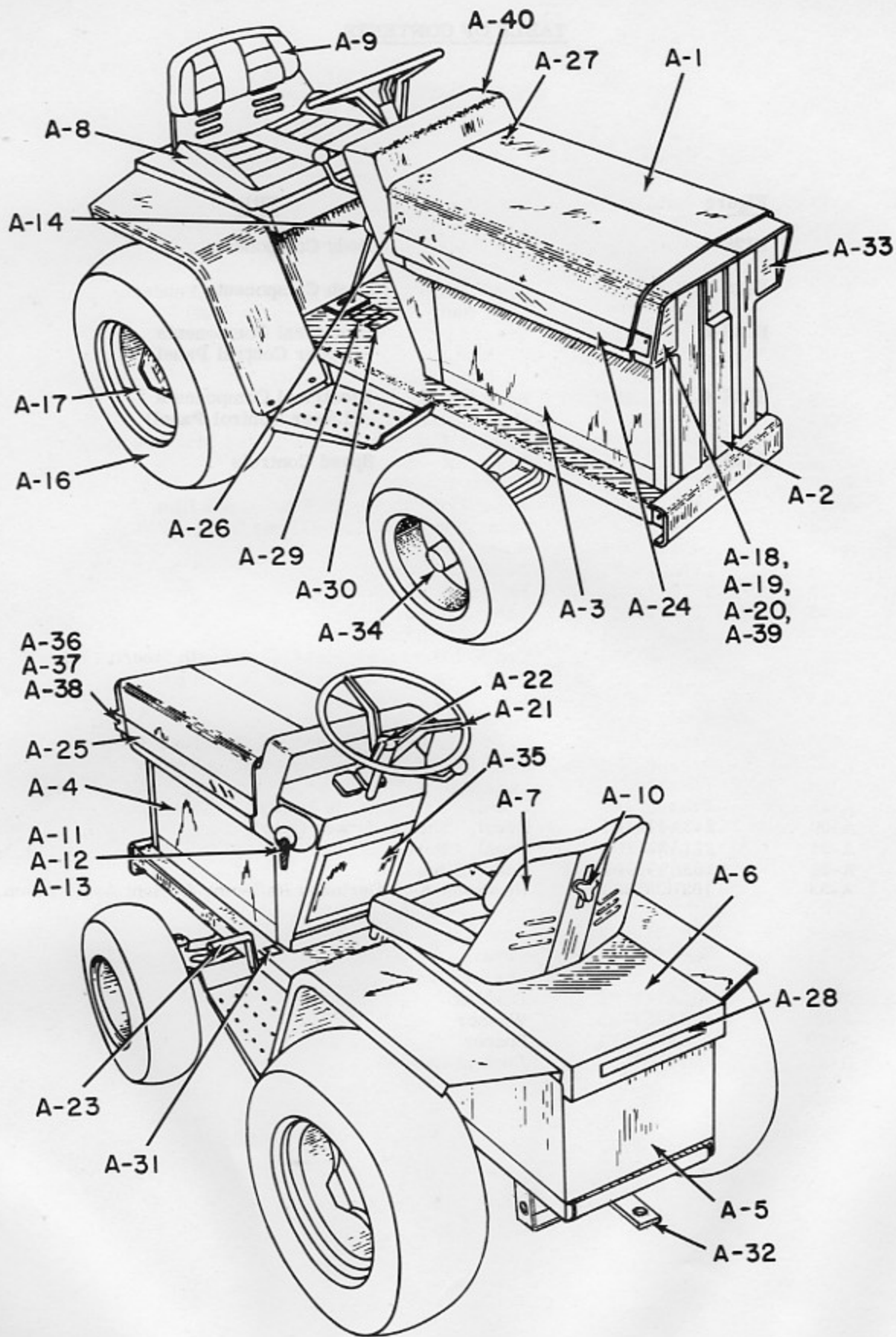

Fig. E12s-1

BODY COMPONENTS

<u>Ref. No.</u>	<u>Part No.</u>	<u>Description</u>
A-1	178B8492G1	Hood Assembly
A-2	423D214P2	Front Grill
A-3	422D837P3	Side Body Panel, Right
A-4	422D838P3	Side Body Panel, Left
A-5	423D221G3	Rear Battery Box Assy. (Includes Fenders)
A-6	541C937G8	Rear Battery Box Cover (Less Seat)
A-7	243A4799P1	Seat Pan (Adjustable Back)
A-8	178B8030P1	Cushion Bottom
A-9	243A4800P1	Cushion, Rear (Adjustable)
A-10	243A4801P1	Rear Seat Knob
A-11	178B8137G1	Power Disconnect
A-12	211A3448G1	Fusible Link (Located on Power Disconnect)
A-13	243A4502P1	Power Disconnect Knob
A-14	211A3249P3	Gearshift Knob
A-15	541C951P1	Front Tire (16 x 4.80/4.00-8) and Rim
A-16	541C658G1	Rear Tire (23 x 8.50-12) and Rim
A-17	243A4589P1	Wheel Lug
A-18	211A3413P1	Headlight Lens
A-19	163B9936G1	Reflector and Socket
A-20	211A3592P1	Lamp (GE 1076)
A-21	163B9843P1	Steering Wheel
A-22	243A4853G1	Cap and Monogram Assy. (Used with Steering Wheel)
A-23		Brake Pedal Assembly (See Section N)
A-24	423D239P1	Hood Decal, Right Hand
A-25	423D239P2	Hood Decal, Left Hand
A-26	243A4639P1	Hood Rubber Bumper (Mounted on Both Sides)
A-27	243A4639P2	Hood Rubber Bumper (Mounted on Top)
A-28	211A3250P1	Rear Tail Reflector
A-29	243A4869P1	Decal, "To Facilitate Shifting"
A-30	243A4794P1	Decal, "Shift to Lower Gear"
A-31	211A3247P1	Decal, "Parking Brake"
A-32	163B9919P1	Conv. Hitch
A-33	163B9878G1	Headlight Asm (Includes Reflector & Light Asm, Lamp, Lens, Hardware & Spacer)
A-34	247A7649P1	Dust Cap
A-35	542C868P2	Cover
A-36	243A4588P1	Machine Screw
A-37	211A3424P1	Bushing
A-38	243A4576P2	Washer
A-39	243A4550P4	Spacer
A-40	423D260P5	Control Cabinet

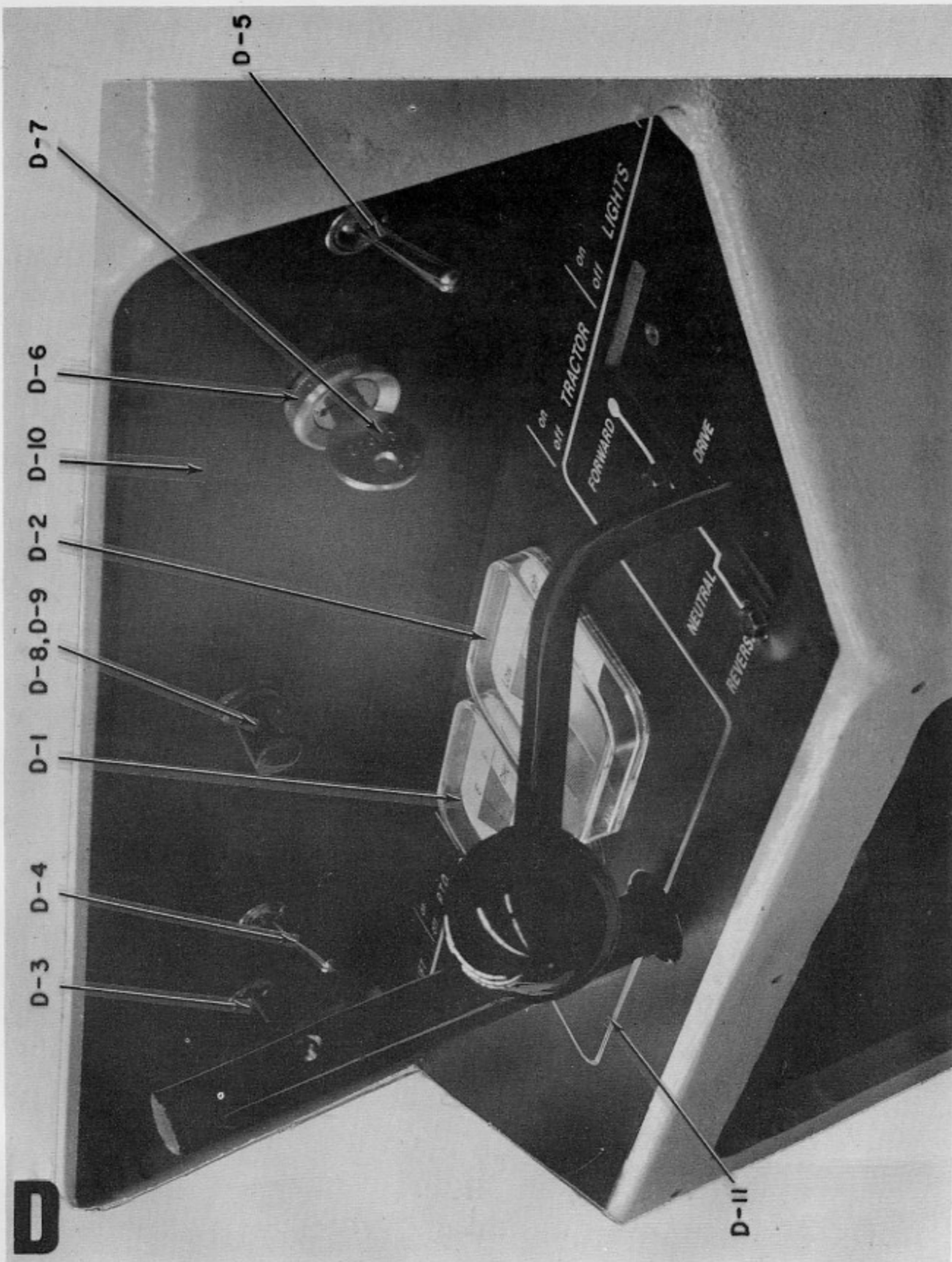

Fig. E12s-2

DASH COMPONENTS

<u>REF. NO.</u>	<u>PART NO.</u>	<u>DESCRIPTION</u>
D-1	243A4629G1	FUEL LEVEL GAUGE
D-2	243A4630G4	POWER USE GAUGE
D-3	243A4531P2	LIFT SWITCH
D-4	243A4531P1	P.T.O. SWITCH
D-5	243A4531P3	LIGHT SWITCH
D-6	243A4573P1	KEY SWITCH
D-7	211A3597P1	KEY
D-8	243A4574P1	LIGHT, DASH
D-9	211A3591P1	LAMP (GE 1815)
D-10	163B9821P1	DASH PANEL
D-11	541C681P1	DECAL, DASH
D-12	541C955G1	DASH HARNESS
D-13	211A3551P1	TUBING (NOT PICTURED—INSULATION ON SWITCH TERMINALS)

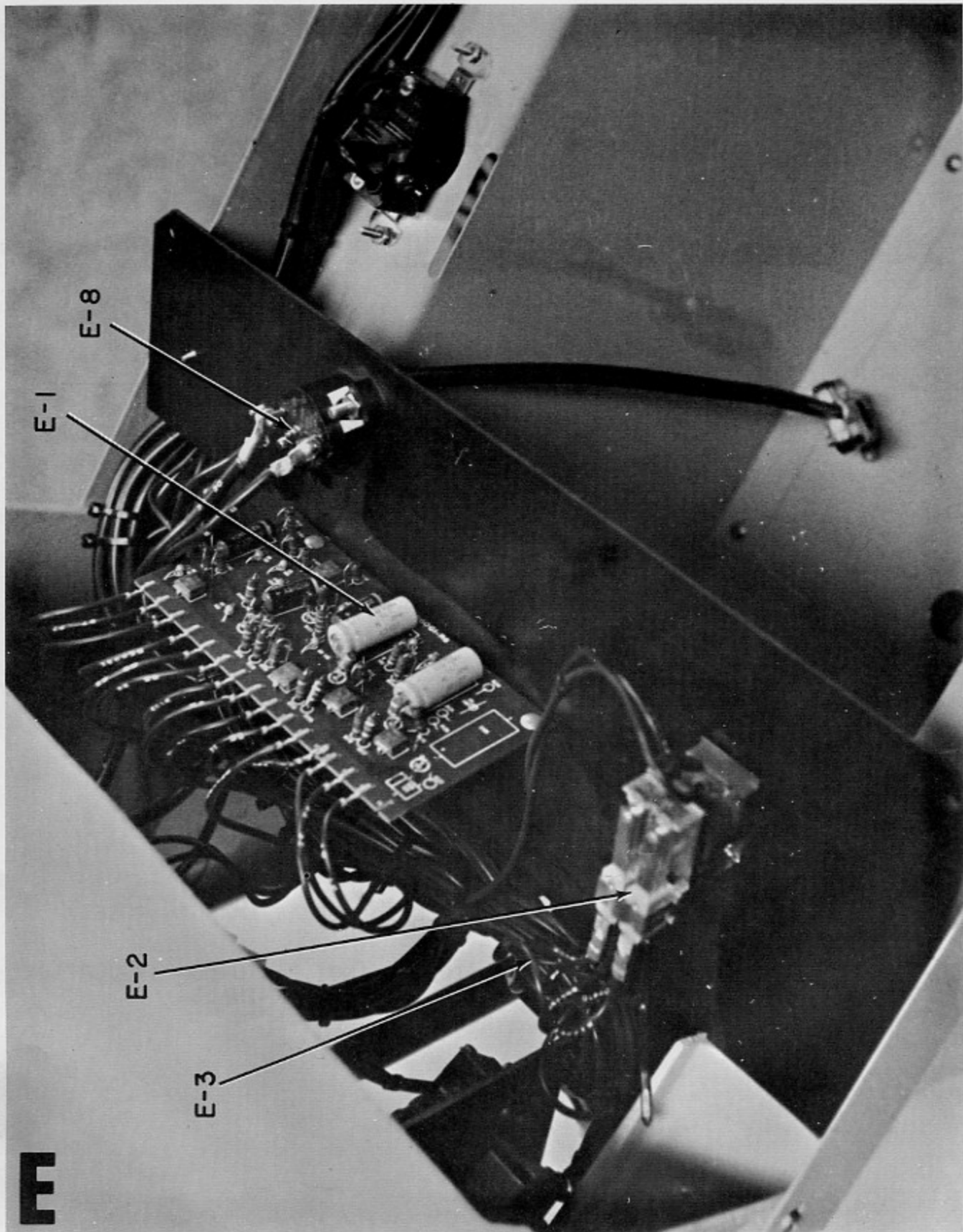

Fig. E12s-3

ELECTRICAL COMPONENTS

(UPPER CONTROL PANEL)

<u>REF. NO.</u>	<u>PART NO.</u>	<u>DESCRIPTION</u>
E-1	163B9814G1	CARD #1
E-2	243A4562P1	RELAY
E-3	423D241G1	CONTROL PANEL HARNESS
E-4	243A4591P1	FUSE BOARD
E-5	211A3528P1	FUSE DECAL
E-6	243A4657P1	FUSE 20 AMP, FU3, FU4
E-7	243A4597P1	FUSE 30 AMP, SLO BLO, FU2
E-8	243A4719P1	CIRCUIT BREAKER (MANUAL RESET)

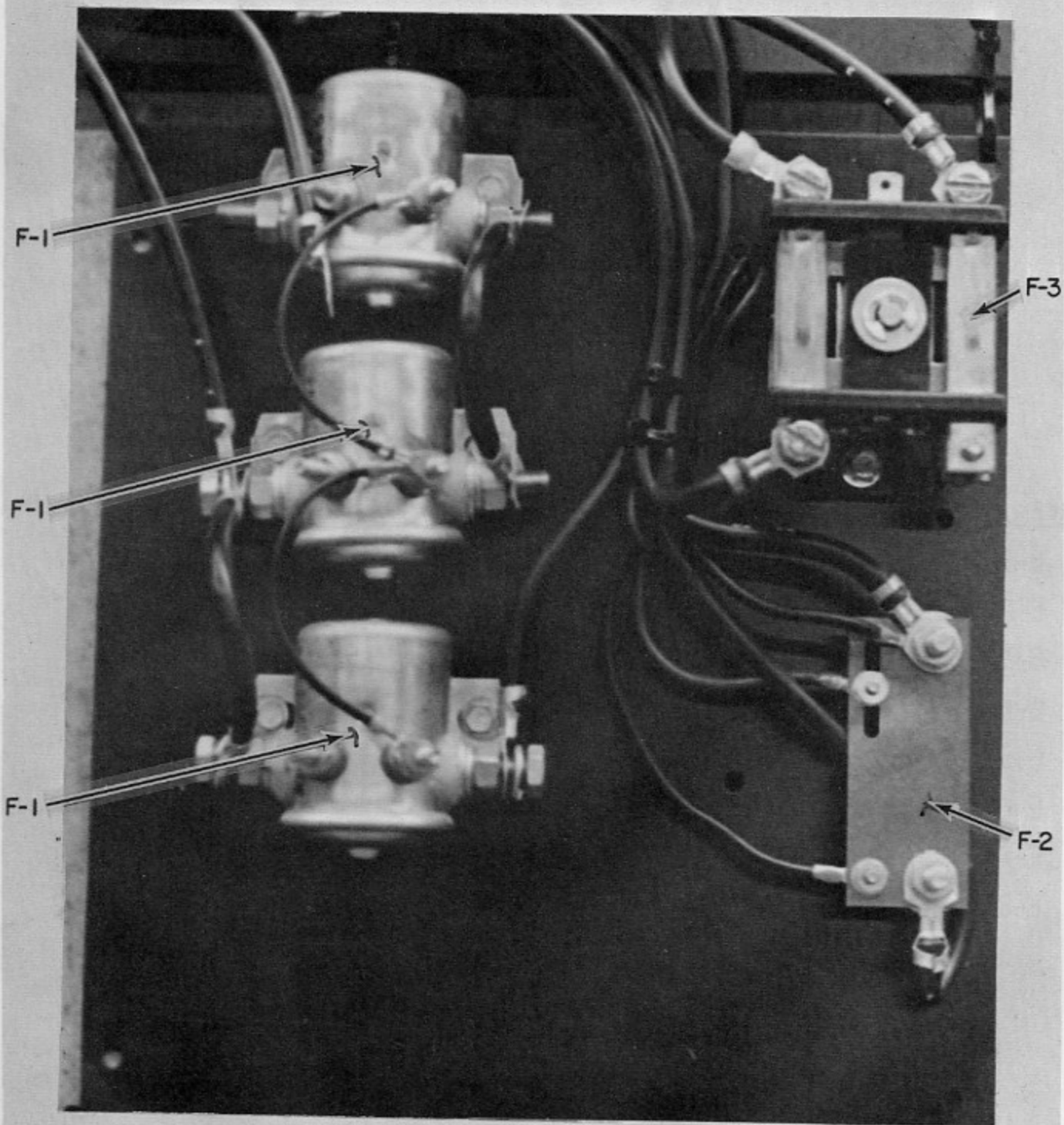

Fig. E12s-4

ELECTRICAL COMPONENTS

(LOWER CONTROL PANEL)

<u>REF. NO.</u>	<u>PART NO.</u>	<u>DESCRIPTION</u>
F-1	211A3567P1	CONTACTOR
F-2	211A3164G1	METER SHUNT ASSEMBLY
F-3	243A4524P1	P.T.O. CONTACTOR

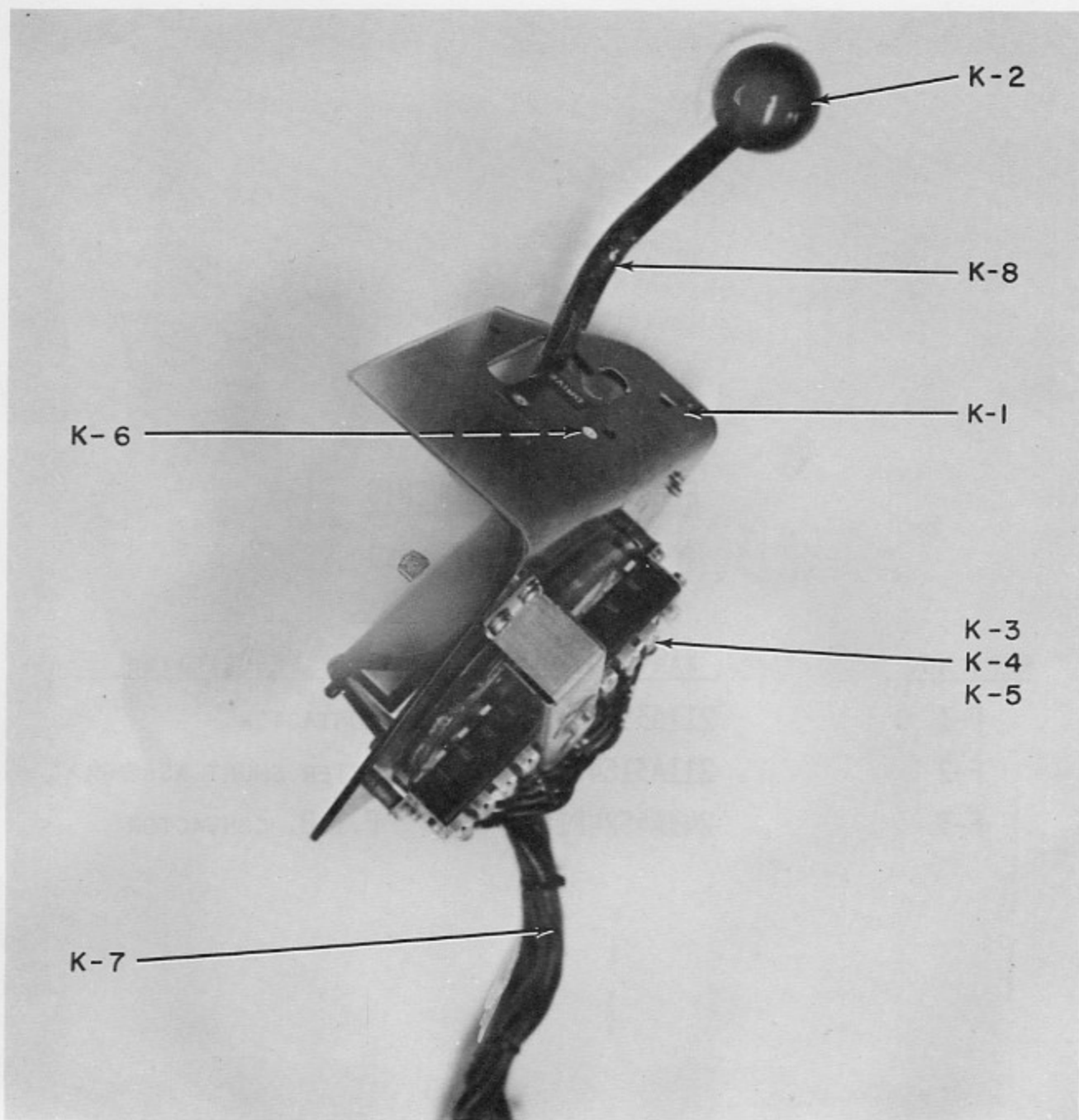

Fig. E12s-5

SPEED CONTROL

<u>Ref. No.</u>	<u>Part No.</u>	<u>Description</u>
K-1*	423D213G3	Speed Control (E12AA)
K-1*	423D213G4	Speed Control (E12BA)
K-2	211A3249P1	Speed Control Knob
K-3	211A3198P1	Start Switch, 3 Tabs, N. O. , N. C. , and Common
K-4	211A3198P2	1A, 2A Switch, 2 Tabs, N. O. , O. , and Common
K-6	211A3558P1	Reverse Switch
K-7*	541C919G1	Throttle Harness (E12BA)
K-7*	541C957G1	Throttle Harness (E12AA)
K-8	211A3239G1	Lever

\*It is imperative, when ordering a speed control or parts, that you specify the model number of the tractor and serial number of the tractor to insure receiving the proper part.

NOTE: Roll Pin connecting throttle lever to cam shaft must be replaced by clevis pin, Part No. 247A7830P1, and cotter pin, Part No. N503P312 1/32 x 3/4 LG. to improve throttle assembly.

E12

TABLE OF CONTENTS

<u>Figure</u>	<u>Title</u>
E12-1	Body Components
E12-2	Dash Components
E12-3	Electrical Components (Upper Control Panel)
E12-4	Electrical Components (Lower Control Panel)
E12-5	Speed Controls

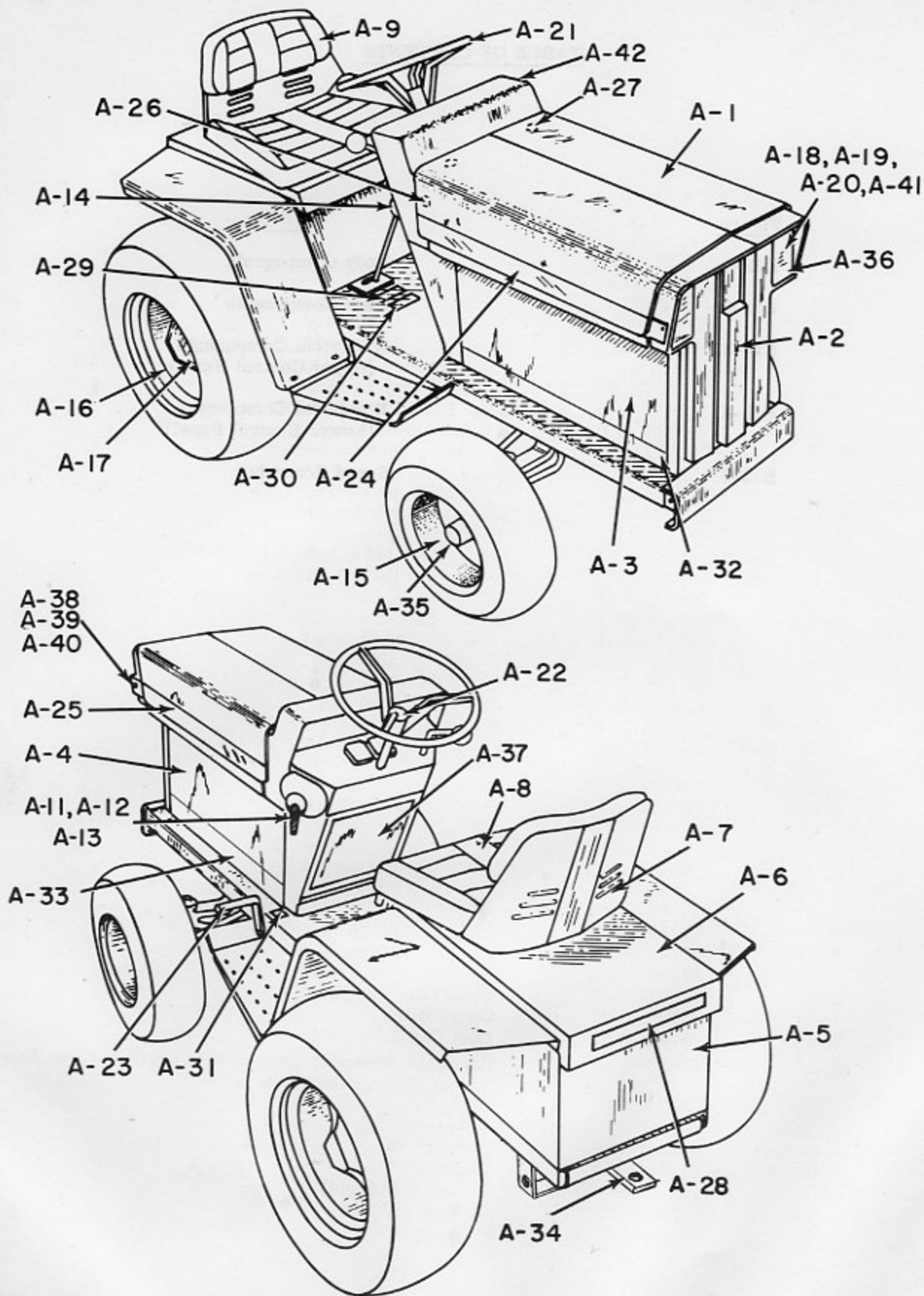

Fig. E12-1

BODY COMPONENTS

<u>Ref. No.</u>	<u>Part No.</u>	<u>Description</u>
A-1	178B8492G1	Hood Assembly
A-2	423D214P2	Front Grill
A-3	422D837P3	Side Body Panel, Right
A-4	422D838P3	Side Body Panel, Left
A-5	423D221G3	Rear Battery Box Assembly, (Includes Fenders)
A-6	541C937G8	Rear Battery Box Cover (Less Seat)
A-7	243A4770P1	Seat Pan (Non-Adjustable Back)
A-8	178B8030P1	Cushion Bottom
A-9	243A4852P1	Cushion, Rear (Non-Adjustable)
A-11	178B8137G1	Power Disconnect
A-12	211A3448G1	Fusible Link (Located on Power Disconnect)
A-13	243A4502P1	Power Disconnect Knob
A-14	211A3249P3	Gearshift Knob
A-15	541C951P1	Front Tire (16 x 4.80/4.00-8) and Rim
A-16	541C658G1	Rear Tire (23 x 8.50-12) and Rim
A-17	243A4589P1	Wheel Lug
A-18	211A3413P1	Headlight Lens
A-19	163B9936G1	Reflector and Light Assembly
A-20	211A3592P1	Lamp (GE 1076)
A-21 *	163B9843P1	Steering Wheel (CA, DA)
A-21	423D255P1	Steering Wheel (HA, JA, JD)
A-22 *	243A4853G1	Cap and Monogram Assembly (CA, DA)
A-22	243A4828G1	Cap & Monogram Assy (HA, JA, JD)
A-23		Brake Pedal Assembly (See Section N)
A-24	127D8091P3	Hood Decal, Right Hand
A-25	127D8091P4	Hood Decal, Left Hand
A-26	243A4639P1	Hood Rubber Bumper (Mounted on Both Sides)
A-27	243A4639P2	Hood Rubber Bumper (Mounted on Top)
A-28	211A3250P1	Rear Tail Reflector
A-29 *	243A4869P1	Decal, "To Facilitate Shifting" (AA thru HA)
A-29	247A7473P1	Decal "To Facilitate Shifting" (JA + Later)
A-30	243A4794P1	Decal, "Shift to Lower Gear"
A-31	211A3247P1	Decal, "Parking Brake"
A-32	127D8095P3	Elec-Trak Insignia RH
A-33	127D8095P4	Elec-Trak Insignia LH
A-34	163B9919P1	Conv. Hitch
A-35	247A7649P1	Dust Cap
A-36	163B9878G1	Headlight Assembly (Includes Reflector & Light Asm, Lamp, Lens, Hardware & Spacer)
A-37	542C868P2	Cover
A-38	243A4588P1	Machine Screw
A-39	211A3424P1	Bushing
A-40	243A4576P2	Washer
A-41	243A4550P4	Spacer (Headlight)
A-42	423D260P5	Control Cabinet

\*When ordering this item it is imperative that care be taken to specify the model number and serial number of the tractor to insure your receiving the proper part.

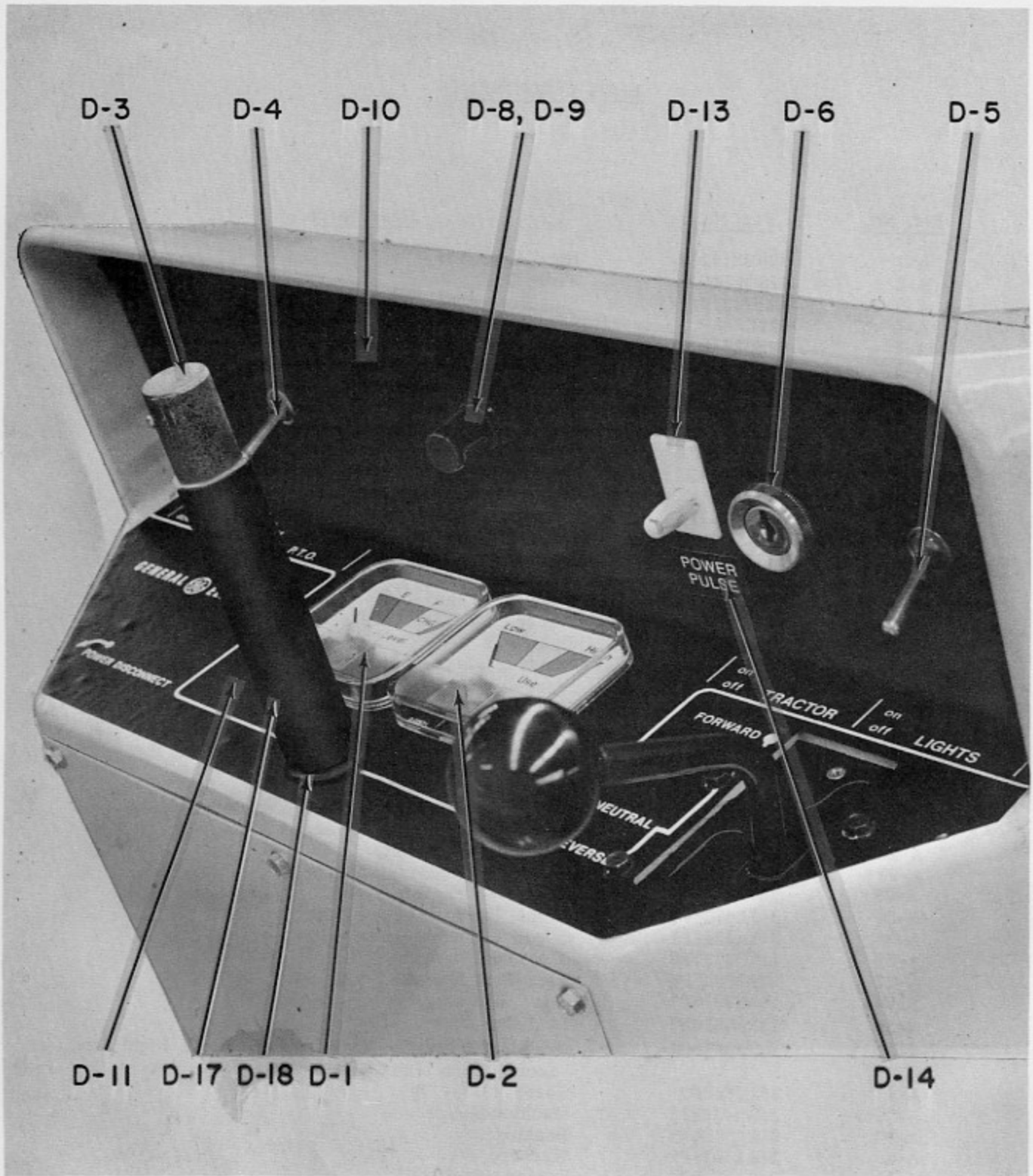

Fig. E12-2

DASH COMPONENTS

<u>Ref. No.</u>	<u>Part No.</u>	<u>Description</u>
D-1	243A4629G1	Fuel Level Gage
D-2	243A4630G4	Power Use Gage
D-3	243A4531P2	Lift Switch
D-4	243A4531P1	P. T. O. Switch
D-5	243A4531P3	Light Switch
D-6	243A4573P1	Key Switch (E12CA, DA, HA)
D-6	244A7308P1	Key Switch (JA, JD)
D-7	211A3597P1	Key (E12CA, DA)
D-7	247A7354P1	Key (E12HA, JA, JD)
D-8	243A4574P1	Light, Dash
D-9	211A3591P1	Lamp (GE 1815)
D-10	Order Ref. D-16	Dash Panel
D-11	Order Ref. D-16	Decal, Dash
D-12	541C967G1	Dash Harness (E12CA, DA, HA)
D-12	158C9052G1	Dash Harness (JA, JD)
D-13	243A4790P1	Power Pulse Switch
D-14	244A7088P1	Decal, Power Pulse
D-15	211A3551P1	Tubing (Not Pictured--Insulation on Switch Terminals)
D-16*	127D8090P2	Dash Panel (Not Shown) (CA, DA, HA)
D-16*	127D8106P2	Dash Panel (JA, JD) (not shown)
D-17*	243A4809P1	Sleeve
D-17*	243A4809P2	Sleeve (JA and Later Models)
D-18	243A4576P3	Washer

\*When ordering this item it is imperative that care be taken to specify the model number and serial number of the tractor to insure your receiving the proper part.

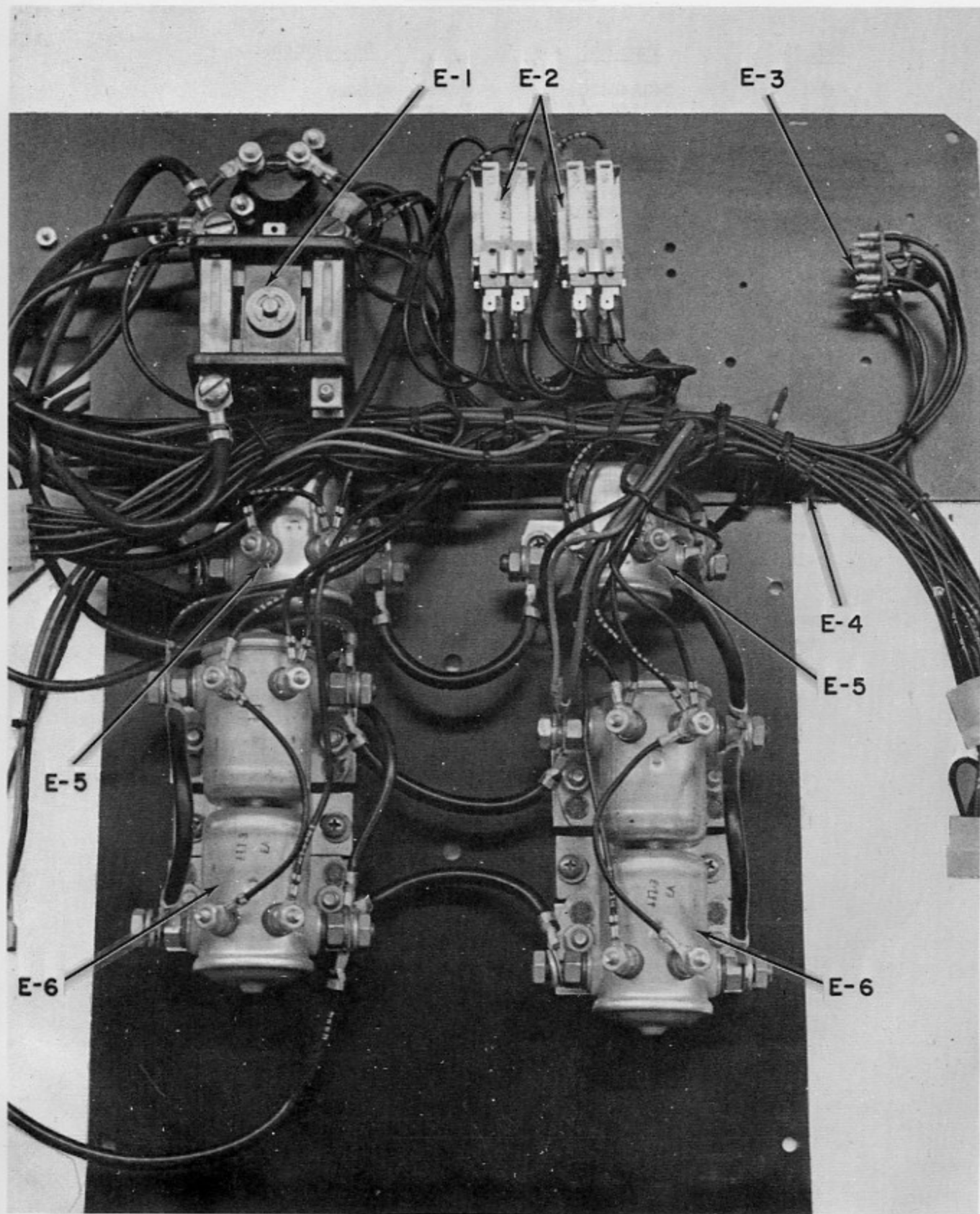

Fig. E12-3

ELECTRICAL COMPONENTS

(Upper Control Panel)

<u>Ref. No.</u>	<u>Part No.</u>	<u>Description</u>
E-1	243A4524P1	P. T. O. Contactor
E-2	243A4562P1	Relay
E-3	243A4970G1	Diode and Varistor Assembly
E-4	423D229G1	Control Panel Harness
E-5	211A3567P1	Contactor
E-6	178B8009P1	Double Contactor

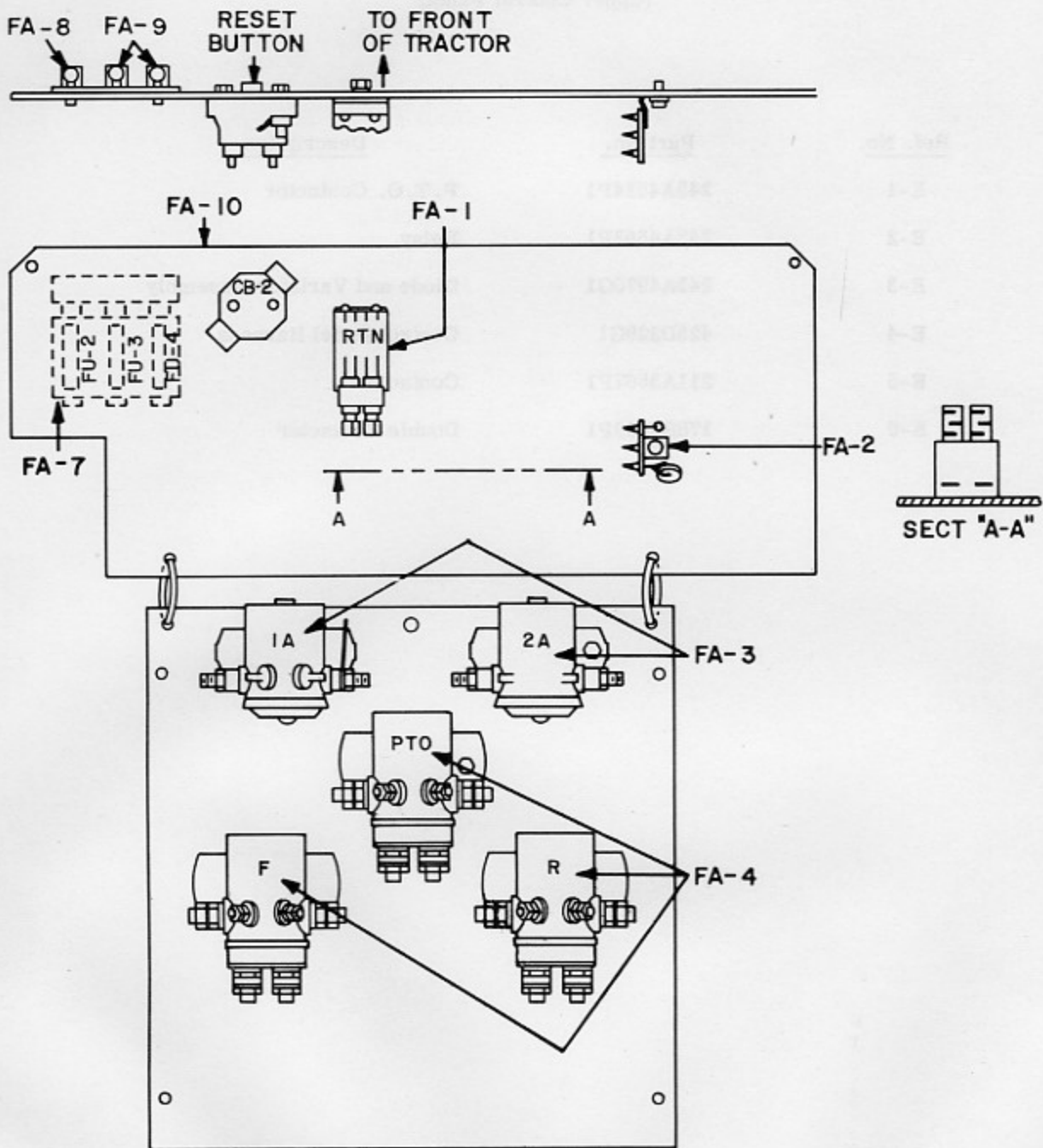

Fig. E12-4

ELECTRICAL COMPONENTS

<u>Ref. No.</u>	<u>Part No.</u>	<u>Description</u>
FA-1	243A4562P1	Relay
FA-2	178B8457G2	Diode and Varistor Asm.
FA-3*	211A3567P1	Contactor (1A, 2A) (All Except JD Model)
FA-3*	247A7462P1	Contactor (1A, 2A) JD Only
FA-4	178B8385P1	Contactor (P. T. O., F, R)
FA-5	127D8112G1	Control Panel Harness (Not Shown)
FA-6	178B8310G1	Control Panel Adder Harness (Not Shown)
FA-7	244A7463P1	Fuse Block
FA-8	243A4597P1	Fuse 30
FA-9	243A4657P1	Fuse 20
FA-10	243A4719P1	Circuit Breaker

\*When ordering this item it is imperative that care be taken to specify the model number and serial number of the tractor to insure your receiving the proper part.

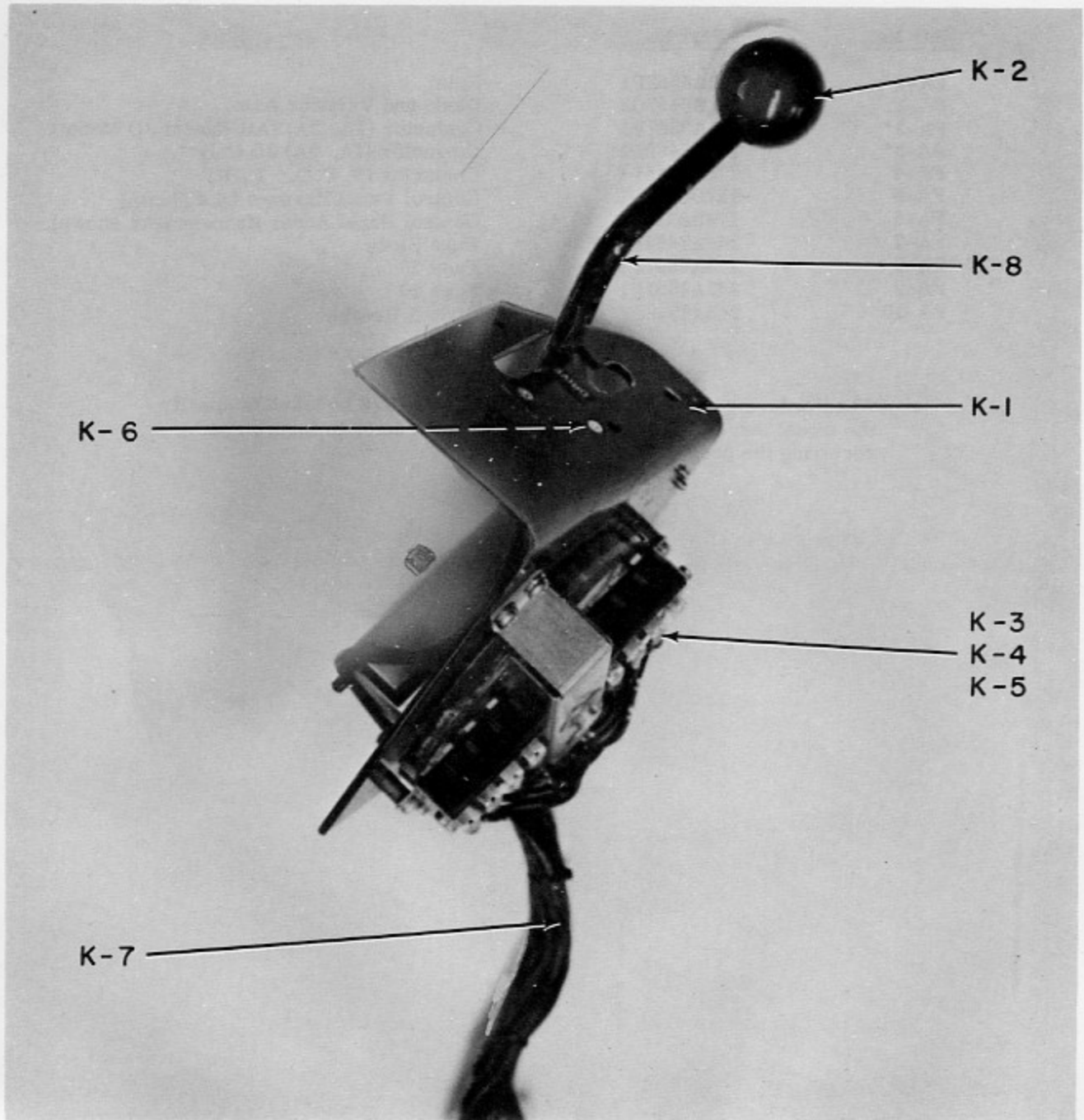

Fig. E12-5

SPEED CONTROL

<u>Ref. No.</u>	<u>Part No.</u>	<u>Description</u>
K-1*	423D259G1	Speed Control (E12CA)
K-1*	423D297G1	Speed Control (E12DA, HA)
K-1*	423D297G3	Speed Control (E12JA, JD)
K-2	211A3249P1	Speed Control Knob
K-3	211A3198P1	Start Switch, 3 Tabs, N.O., N.C., and Common
K-4	211A3198P2	1A, 2A Switch, 2 Tabs, N.O. and Common (Also Rev. Sw. in E12CA)
K-6	211A3558P2	Reverse Switch (E12DA, HA, JA, JD)
K-7*	541C985G1	Throttle Harness (E12CA)
K-7*	155C8065G1	Throttle Harness (E12DA, HA)
K-7*	158C9044G1	Throttle Harness (E12JA, JD)
K-8	211A3239G1	Lever

\* It is imperative when ordering a speed control or parts, that you specify the model number of the tractor and serial number of the tractor to insure receiving the proper part.

NOTE: Roll Pin connecting throttle lever to cam shaft must be replaced by clevis pin, Part No. 247A7830P1, and cotter pin, Part No. N503P312 1/32 x 3/4 LG. to improve throttle assembly.

E12M

TABLE OF CONTENTS

<u>Figure</u>	<u>Title</u>
E12M-1	Body Components
E12M-2	Dash Components
E12M-3	Electrical Components (Upper Control Panel)
E12M-4	Speed Controls

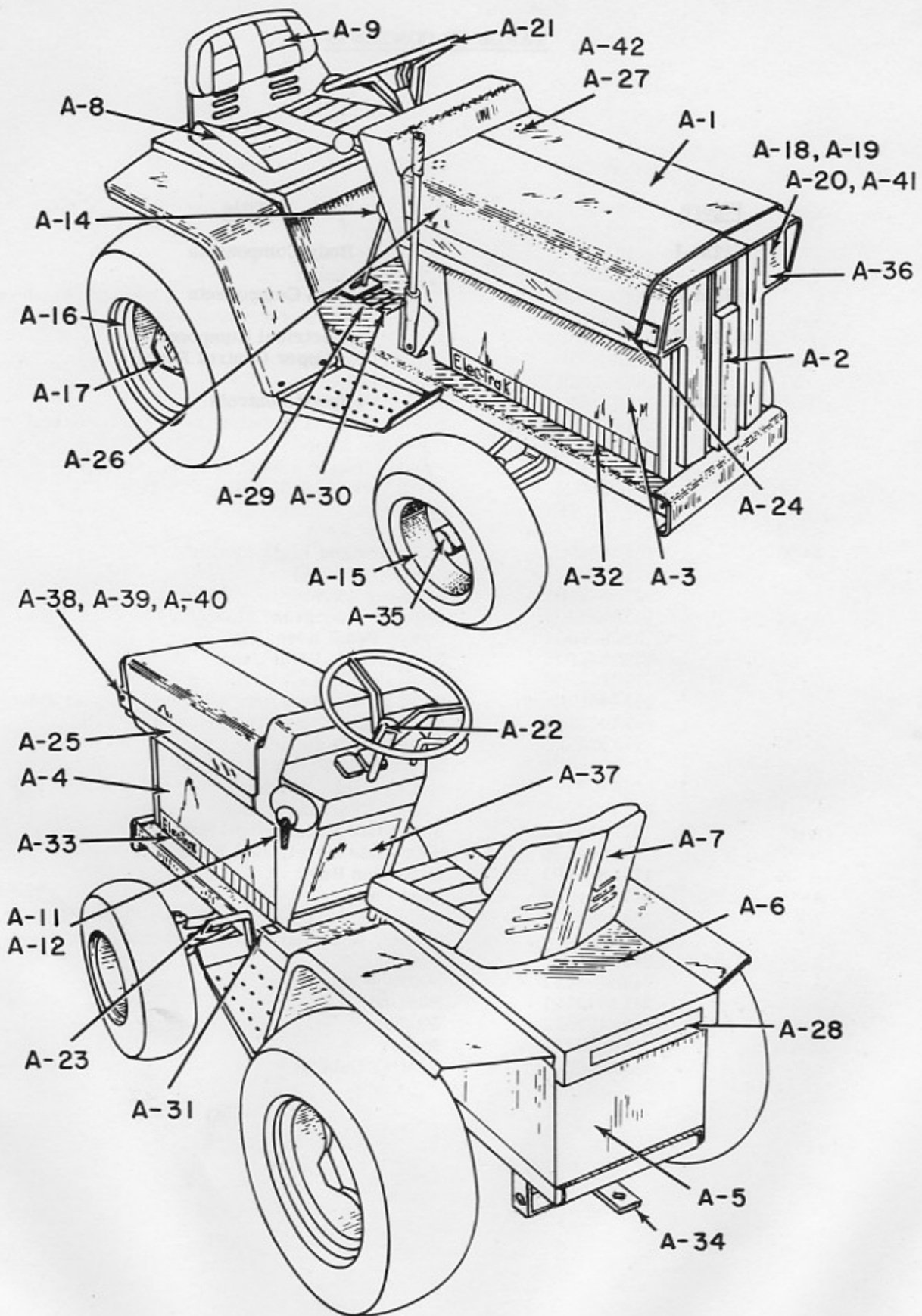

Fig. E12M-1

BODY COMPONENTS

<u>Ref. No.</u>	<u>Part No.</u>	<u>Description</u>
A-1	178B8492G1	Hood Assembly
A-2	423D214P2	Front Grill
A-3	422D837P3	Side Body Panel, Right
A-4	422D838P3	Side Body Panel, Left
A-5	423D221G3	Rear Battery Box Assembly, (Includes Fenders)
A-6	541C937G8	Rear Battery Box Cover (Less Seat)
A-7	243A4770P1	Seat Pan
A-8	178B8030P1	Cushion, Bottom
A-9	243A4852P1	Cushion, Rear
A-11	178B8137G1	Power Disconnect
A-12	211A3448G1	Fusable Link (Located on Power Disconnect)
A-14	211A3249P3	Gearshift Knob
A-15	541C951P1	Front Tire (16 x 4.80/4.00-8) and Rim
A-16	541C658G1	Rear Tire (23 x 8.50-12) and Rim
A-17	243A4589P1	Wheel Lug
A-18	211A3413P1	Headlight Lens
A-19	163B9936G1	Reflector and Light Assembly
A-20	211A3592P1	Lamp (GE 1076)
A-21	127D8023P1	Steering Wheel
A-22	243A4828G2	Cap and Monogram Assembly
A-23	155C8080G2	Brake Pedal Assembly
A-24	422D848P11	Hood Decal, Right Hand
A-25	422D848P12	Hood Decal, Left Hand
A-26	243A4639P1	Hood Rubber Bumper, (Mounted on Both Sides)
A-27	243A4639P2	Hood Rubber Bumper (Mounted on Top)
A-28	211A3250P1	Rear Tail Reflector
A-29	244A7158P1	Decal, "To Facilitate Shifting"
A-30	243A4794P1	Decal, "Shift to Lower Gear"
A-31	211A3247P1	Decal, "Parking Brake"
A-32	127B8095P3	Side Plate Decal, Right Hand
A-33	127B8095P4	Side Plate Decal, Left Hand
A-34	178B8167P1	Extension Bar
A-35	247A7649P1	Dust Cap
A-36	163B9878G1	Headlight Assembly (Includes reflector & light asm, lamp, lens, hardware & spacer)
A-37	542C868P2	Cover
A-38	243A4588P1	Machine Screw
A-39	211A3424P1	Bushing
A-40	243A4576P2	Washer
A-41	243A4550P4	Spacer
A-42	423D260P5	Control Cabinet

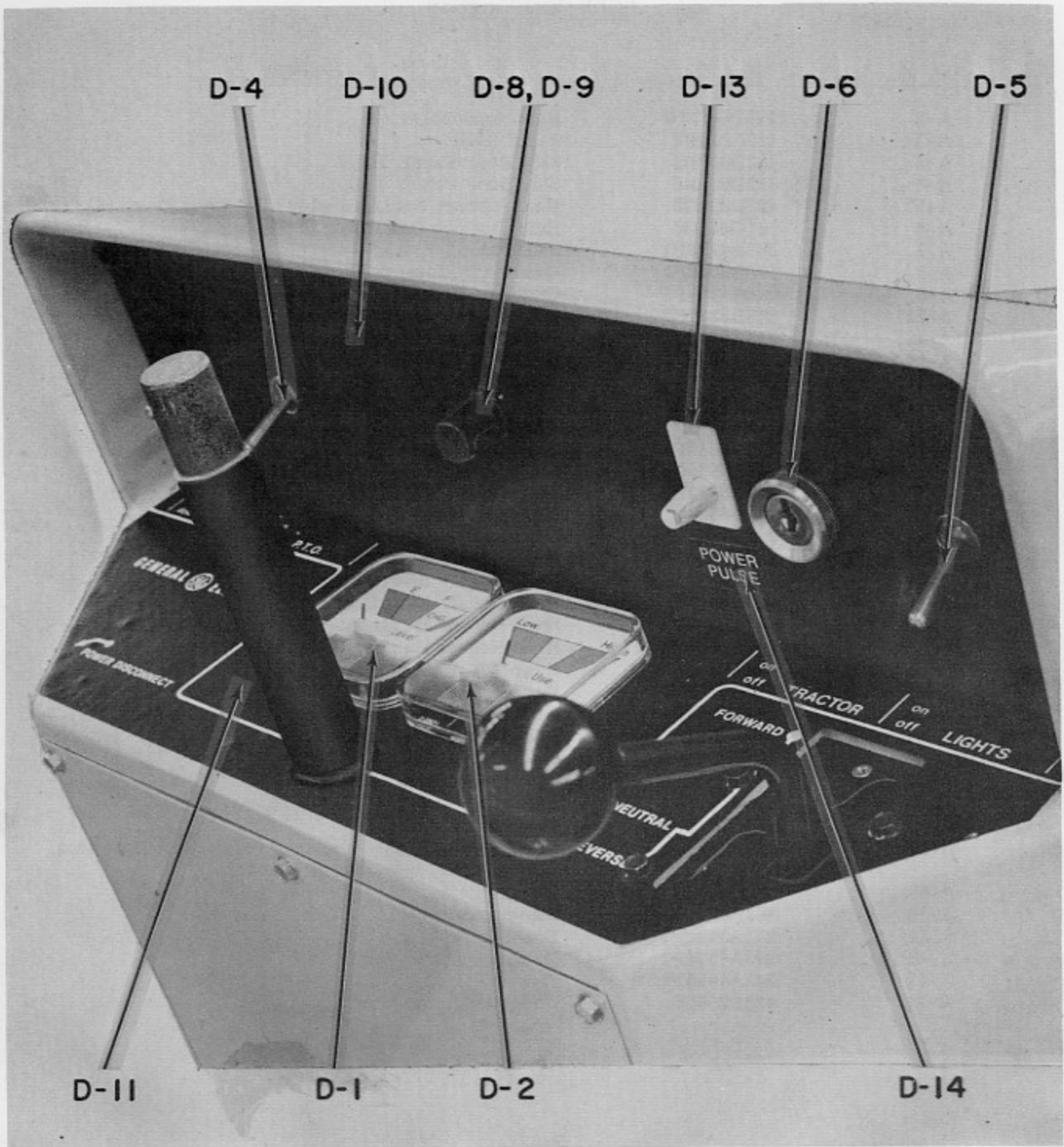

Fig. E12M-2.

DASH COMPONENTS

<u>REF. NO.</u>	<u>PART NO.</u>	<u>DESCRIPTION</u>
D-1	243A4629G1	FUEL LEVEL GAUGE
D-2	243A4630G4	POWER USE GAUGE
D-4	243A4531P1	P.T.O. SWITCH
D-5	243A4531P3	LIGHT SWITCH
D-6	243A4573P1	KEY SWITCH
D-7	211A3597P1	KEY
D-8	243A4574P1	LIGHT, DASH
D-9	211A3591P1	LAMP (GE 1815)
D-10	178B8132P1	DASH PANEL
D-11	541C681P1	DECAL, DASH
D-12	155C8072G1	DASH HARNESS
D-13	243A4790P1	POWER PULSE SWITCH
D-14	244A7088P1	DECAL, POWER PULSE
D-15	211A3551P1	TUBING (NOT PICTURED—INSULATION ON SWITCH TERMINALS)

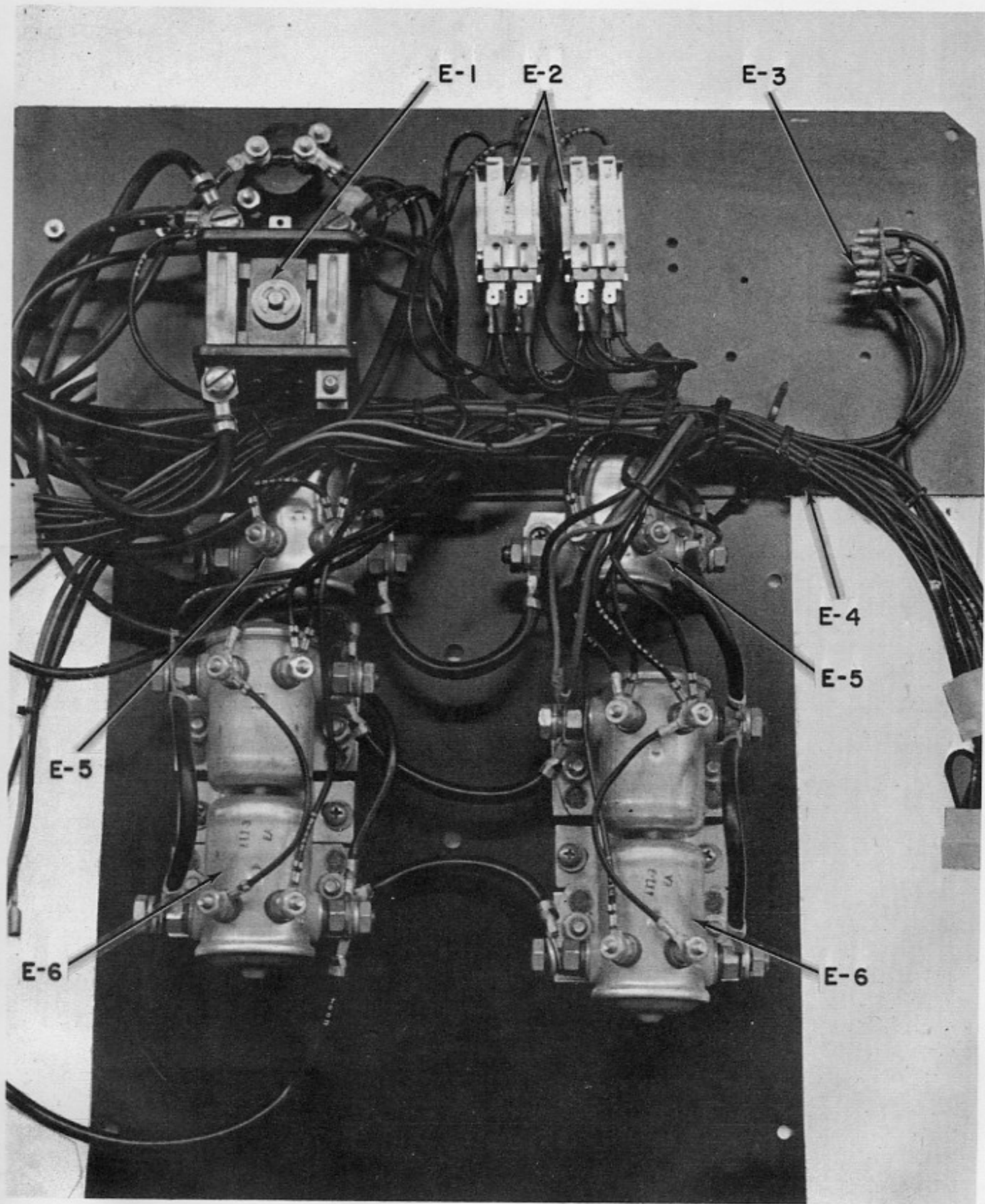

Fig. E12M-3

ELECTRICAL COMPONENTS

<u>REF. NO.</u>	<u>PART NO.</u>	<u>DESCRIPTION</u>
E-1	243A4524P1	P.T.O. CONTACTOR
E-2	243A4562P1	RELAY
E-3	243A4970G1	DIODE AND VARISTOR ASSEMBLY
E-4	423D296G1	CONTROL PANEL HARNESS
E-5	211A3567P1	CONTACTOR
E-6	178B8009P1	DOUBLE CONTACTOR

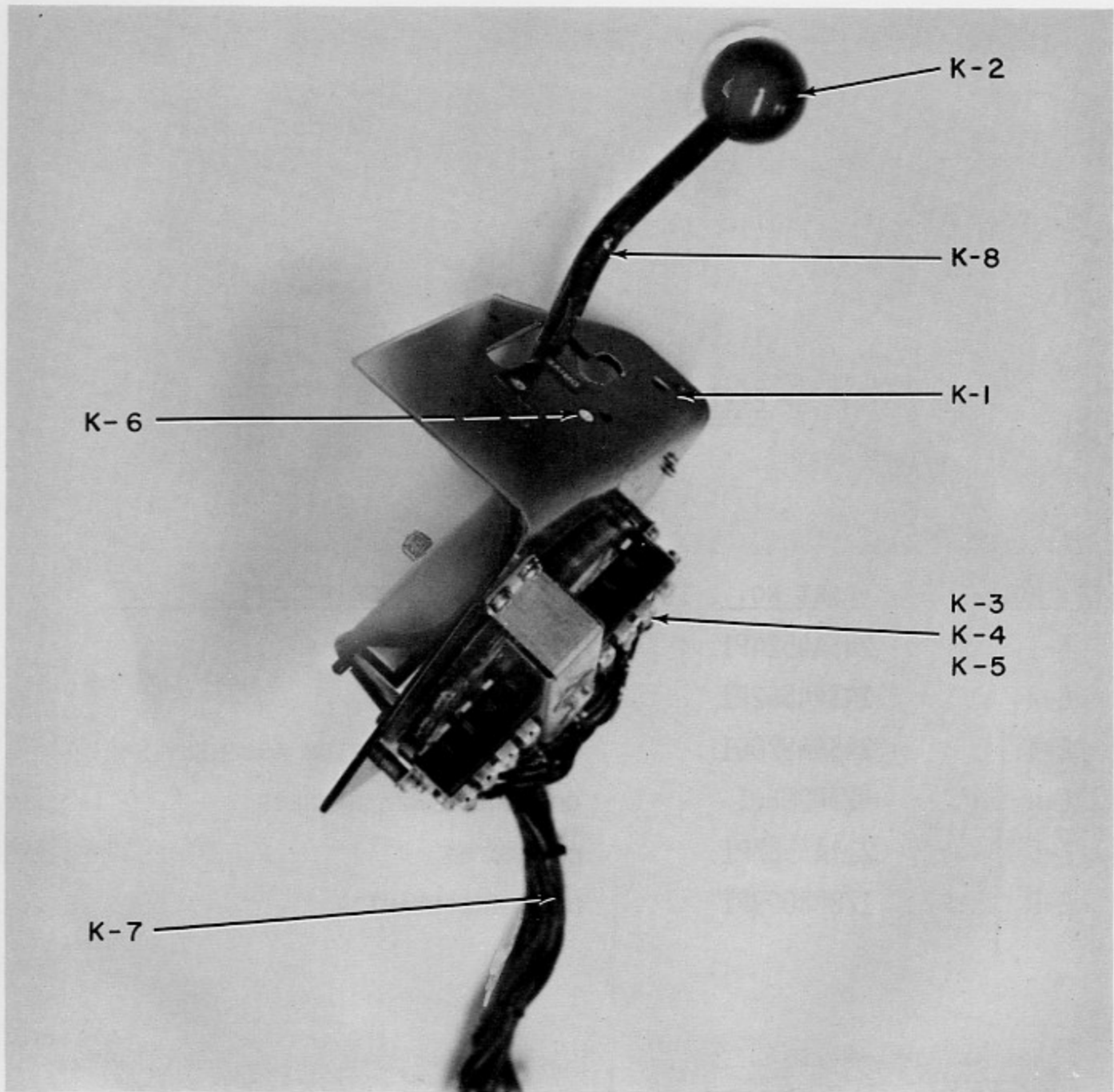

Fig. E12M-4

SPEED CONTROL

<u>Ref. No.</u>	<u>Part No.</u>	<u>Description</u>
K-1*	423D297G1	Speed Control
K-2*	211A3249P1	Speed Control Knob
K-3	211A3198P1	Start Switch, 3 Tabs, N.O., N.C., and Common
K-4	211A3198P2	1A 2A Switch, 2 Tabs, N.O., O, and Common
K-6	211A3558P2	Reverse Switch
K-7*	155C8065G1	Throttle Harness
K-8	211A3239G1	Lever

\*It is imperative, when ordering a speed control or parts, that you specify the model number of the tractor and serial number of the tractor to insure receiving the proper part.

NOTE: Roll Pin connecting throttle lever to cam shaft must be replaced by clevis pin, Part No. 247A7830P1, and cotter pin, Part No. N503P312 1/32 x 3/4 LG. to improve throttle assembly.

E10 AND E8

## TABLE OF CONTENTS

<u>Figure</u>	<u>Title</u>
SF-1	Body Components
SF-2	Front Battery Compartment
SF-3	Charger (See Charger Section)
SF-4	Dash Components
SF-5	Electrical Components (And Motor Compartment)
SF-6	E10M Rear Battery Compartment
SF-7	E8M Rear Battery Compartment
SF-8	Undercarriage Components (AA-CA)
SF-9	Undercarriage Components (DA, EA)
SF-10	Drive Assembly

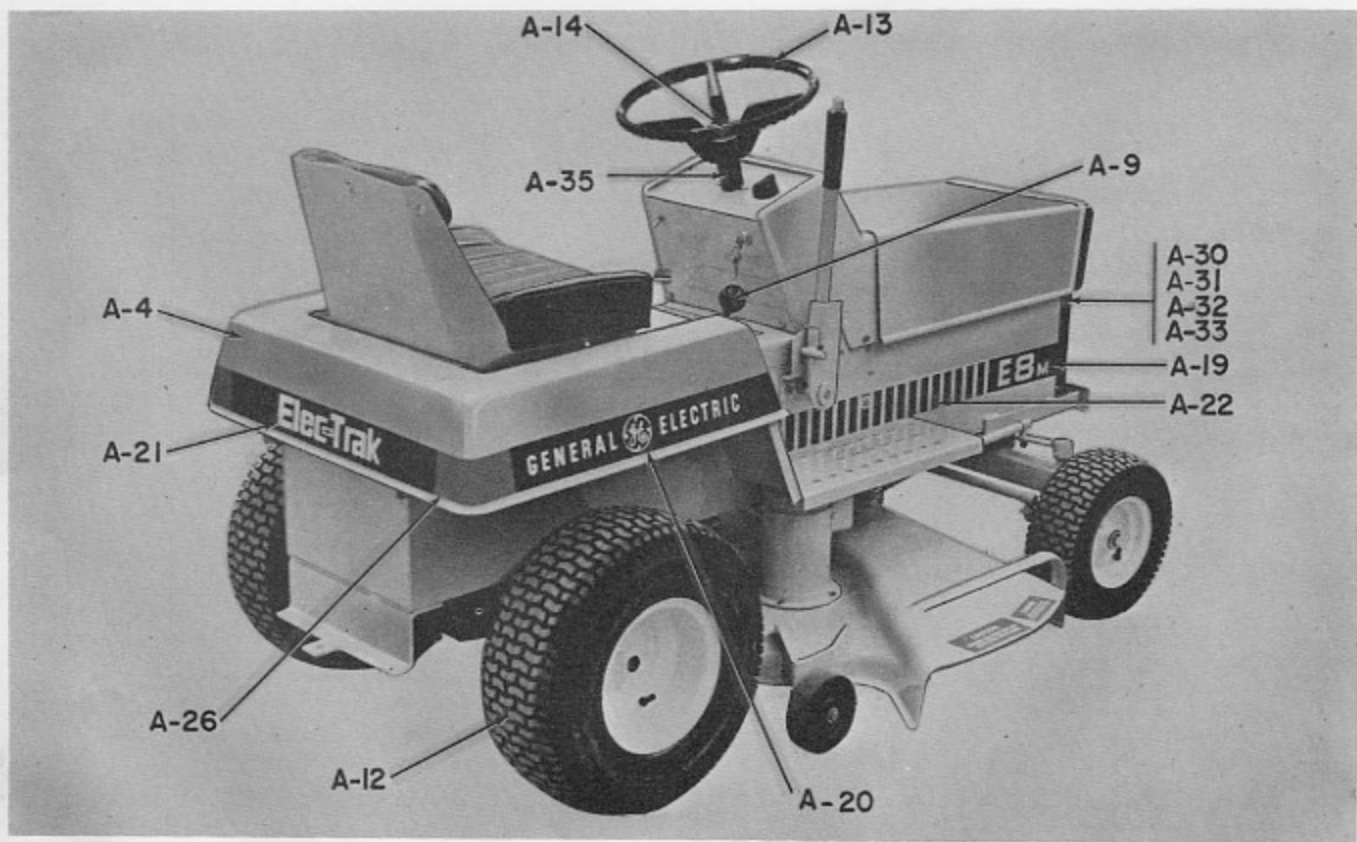
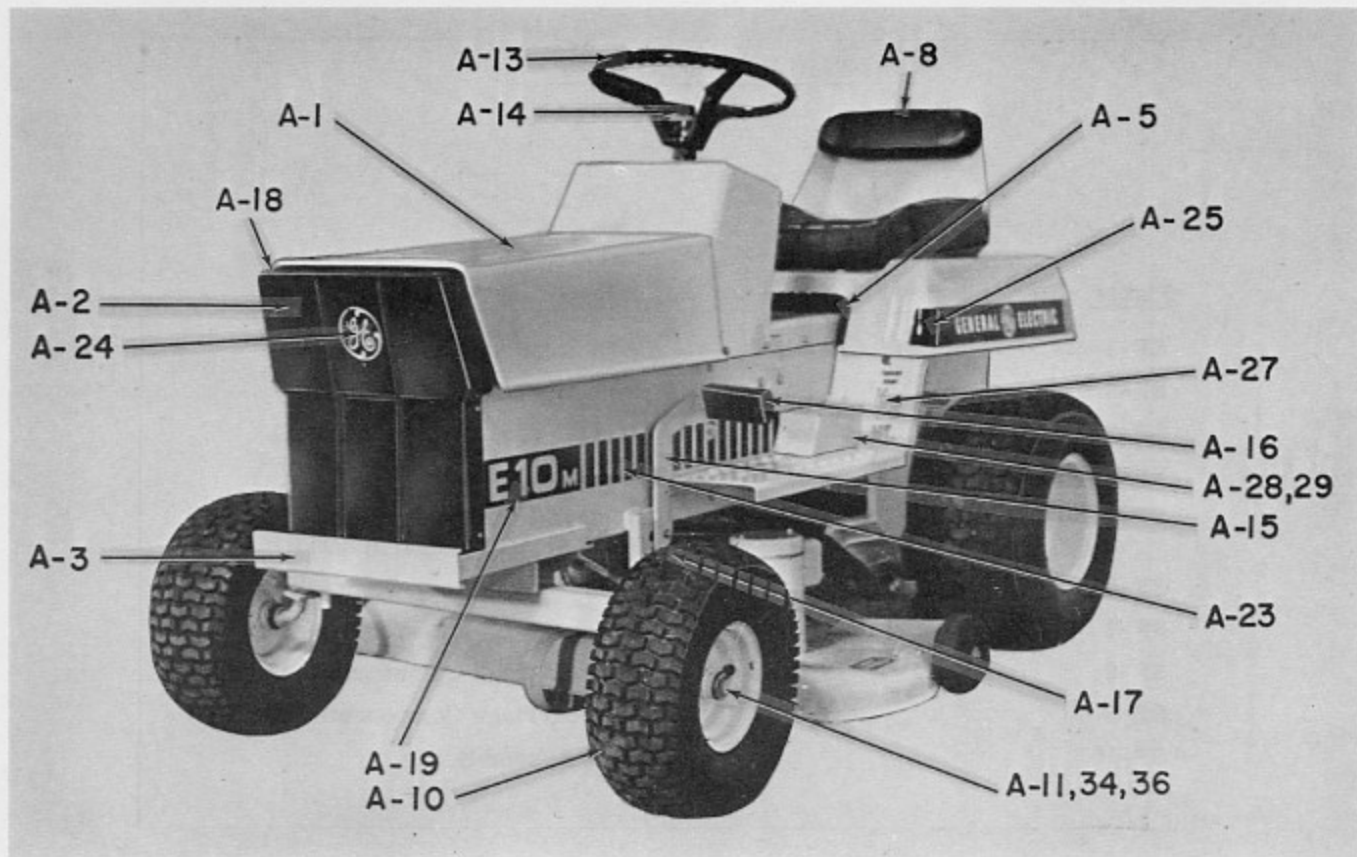

Fig. SF-1

BODY COMPONENTS

<u>Ref. No.</u>	<u>Part No.</u>	<u>Description</u>
A-1	178B8223G2	Hood Assembly
A-2	127D8033P1	Front Grill
A-3	244A7262P1	Bumper
A-4	178B8252G1	Seat Housing Assembly
A-5	244A7448P1	Seat Trim
A-6*	243A4770P1	Seat Pan (All Models Except E8CA, DA, EA)
A-6*	155C8199G1	Seat Assembly E8CA, DA, EA
A-7	243A4852P1	Cushion, Bottom (All Models Except E8CA, DA, EA)
A-8	178B8030P1	Cushion, Rear (All Models Except E8CA, DA, EA)
A-9	211A3249P3	Gear Shift Knob
A-10 *	155C8121G1	Front Tire (13 x 5.00-6) and Rim (E8)
A-10 *	155C8121G2	Front Tire (15 x 6.00-6) and Rim (E10)
A-11	N922P75C6	Snap Ring - 3/4"
A-12 *	155C8125G1	Rear Tire (18 x 6.50-8) and Rim (E8)
A-12 *	155C8131G1	Rear Tire (18 x 9.50-8) and Rim (E10)
A-13	127D8023P1	Steering Wheel
A-14	243A4828G2	Cap and Monogram Assembly
A-15	178B8283G1	Pedal Assembly
A-16	244A7159P1	Brake Pad
A-17	243A4554P3	Push Nut
A-18	244A7448P1	Trim
A-19 *	178B8269P1	Decal, E8M
A-19 *	178B8270P1	Decal, E10M
A-19 *	178B8479P1	Decal, Heavy Duty
A-20	422D848P15	Decal, General Electric
A-21	422D848P16	Decal, Elec-Trak
A-22	422D848P17	Decal, Body (Right Side)
A-23	422D848P18	Decal, Body (Left Side)
A-24	244A7394P1	Decal, General Electric
A-25	178B8261P1	Decal, Corner (Black)
A-26	244A7389P1	Decal, Corner (Red)
A-27	244A7471P1	Parking Brake Decal
A-28	155C8147P1	Belt Cover
A-29	244A7278G1	Belt Retainer (Not Shown Under Belt Cover)
A-30	243A4550P10	Spacer
A-31	N57P16020B6	Slotted Pan Hd. Mach. Screw #10-32 x 1 1/4"
A-32	N405P9C6	Lockwasher #10
A-33	N210P16B6	Hex Nut #10-32
A-34	N402AP18B6	Washer (Spindle) (3/4")
A-35	244A7327P1	Sleeve
A-36	243A4640P1	Front Wheel Bearing

\*When ordering this item it is imperative that care be taken to specify the model number and serial number of the tractor to insure your receiving the proper part.

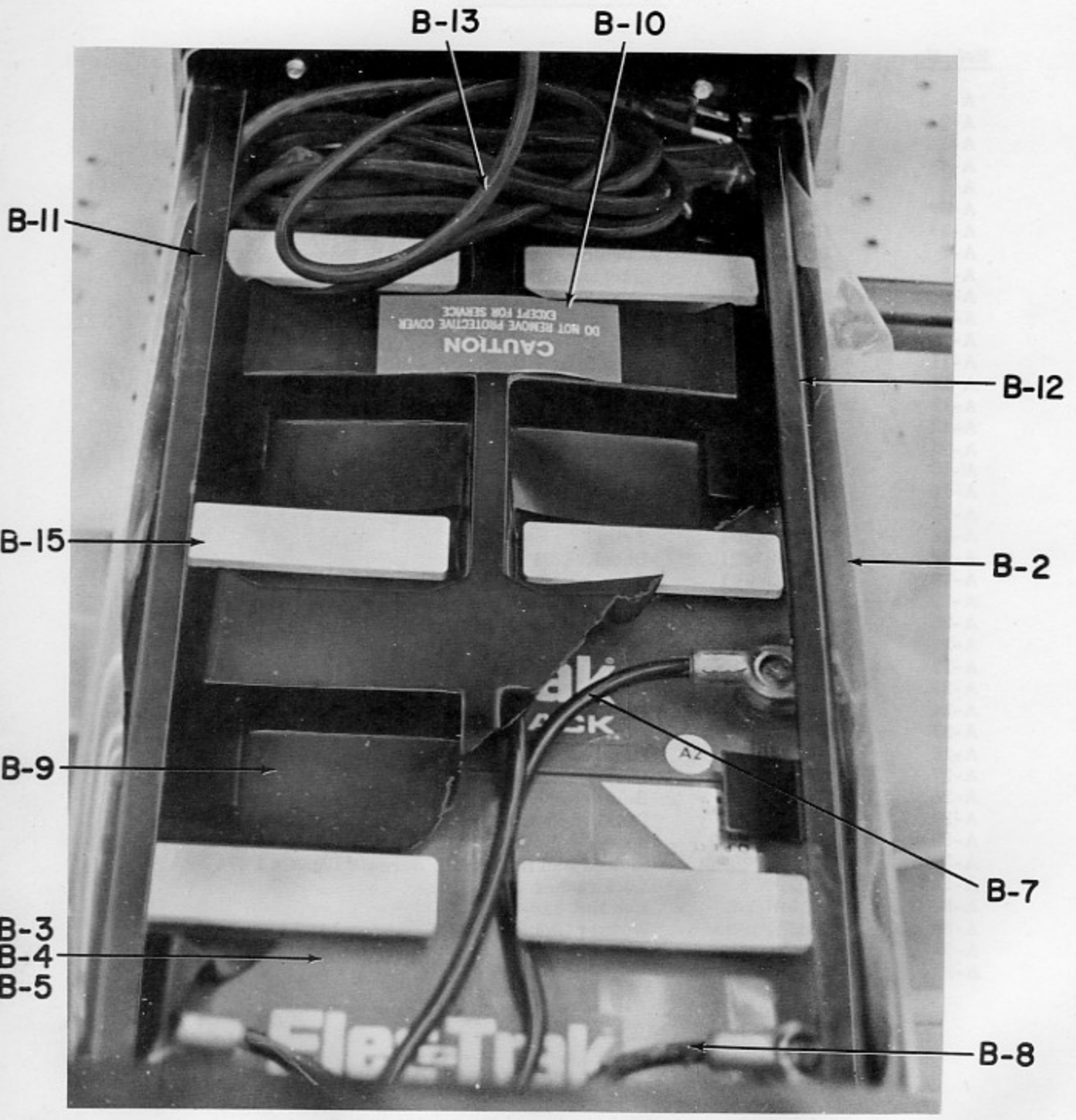

Fig. SF-2

FRONT BATTERY COMPARTMENT

<u>Ref. No.</u>	<u>Part No.</u>	<u>Description</u>
B-1	155C8094P1	Battery Tray (Not Pictured)
B-2	155C8122P1	Battery Liner
B-3	178B8236P1	Battery
B-4	244A7313P2	Battery Protector (Not Pictured-Front)
B-5	244A7313P1	Battery Protector (Not Pictured-Rear)
B-6	178B8165G7	Battery Cable (Not Pictured-B2+)
B-7	178B8165G10	Battery Cable ( Interconnecting )
B-8	178B8165G8	Battery Cable (B3-)
B-9	247A7307G1	Battery Cover (Includes Decal)
B-11	178B8263P1	Battery Clamp (Right Side)
B-12	178B8263P2	Battery Clamp (Left Side)
B-13	211A3555G1	Cord Asm.
B-14	155C8167P1	Decal, Charging Instruction (Not Shown)
B-15	247A7496P1	Battery Cap

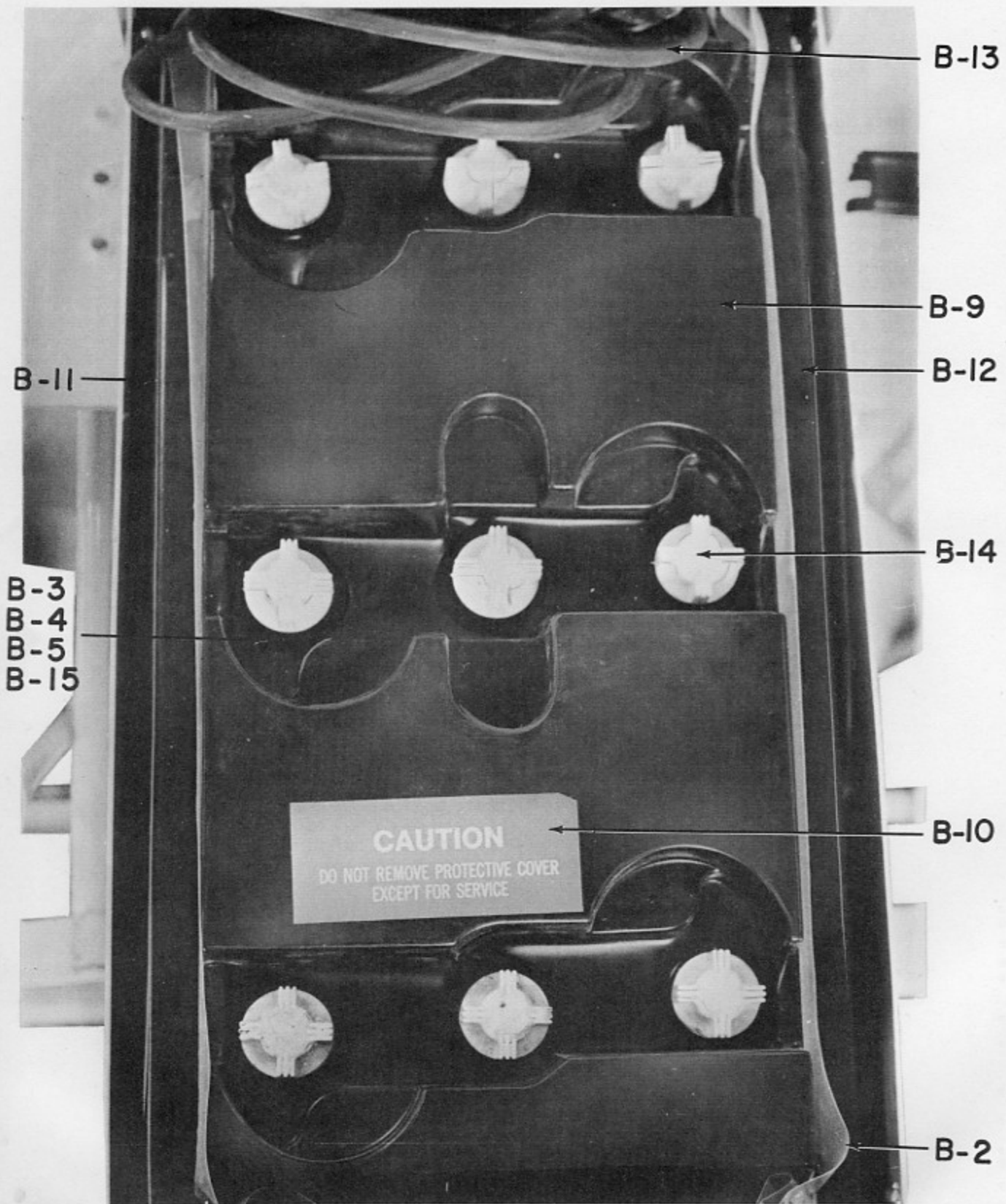

Fig. SF-3

FRONT BATTERY COMPARTMENT

<u>Ref. No.</u>	<u>Part No.</u>	<u>Description</u>
B-1	155C8094P1	Battery Tray (Not Pictured)
B-2	155C8122P1	Battery Liner
B-3	243A4527G1	Battery Std.
B-3	243A4724G1	Battery H. D.
B-4	244A7313P4	Battery Protector (Not Pictured-Front)
B-5	244A7313P3	Battery Protector (Not Pictured-Rear)
B-6	178B8165G7	Battery Cable (Not Pictured-B2 <sup>+</sup> )
B-7	178B8165G1	Battery Cable (Interconnecting ) (Not Pictured)
B-8	178B8165G11	Battery Cable (B3 <sup>-</sup> )
B-9	247A7308G1	Battery Cover (Includes Decal)
B-11	244A7283P2	Battery Clamp (Right Side)
B-12	244A7283P1	Battery Clamp (Left Side)
B-13	211A3555G1	Cord Asm.
B-14	243A4849P1	Battery Cap Old HD
	243A4720P1	Battery Cap New HD + Std.
B-15	244A7313P5	Battery Protector (Not Pictured-Side)
B-16	155C8167P1	Decal, Charging Instruction (Not Shown)

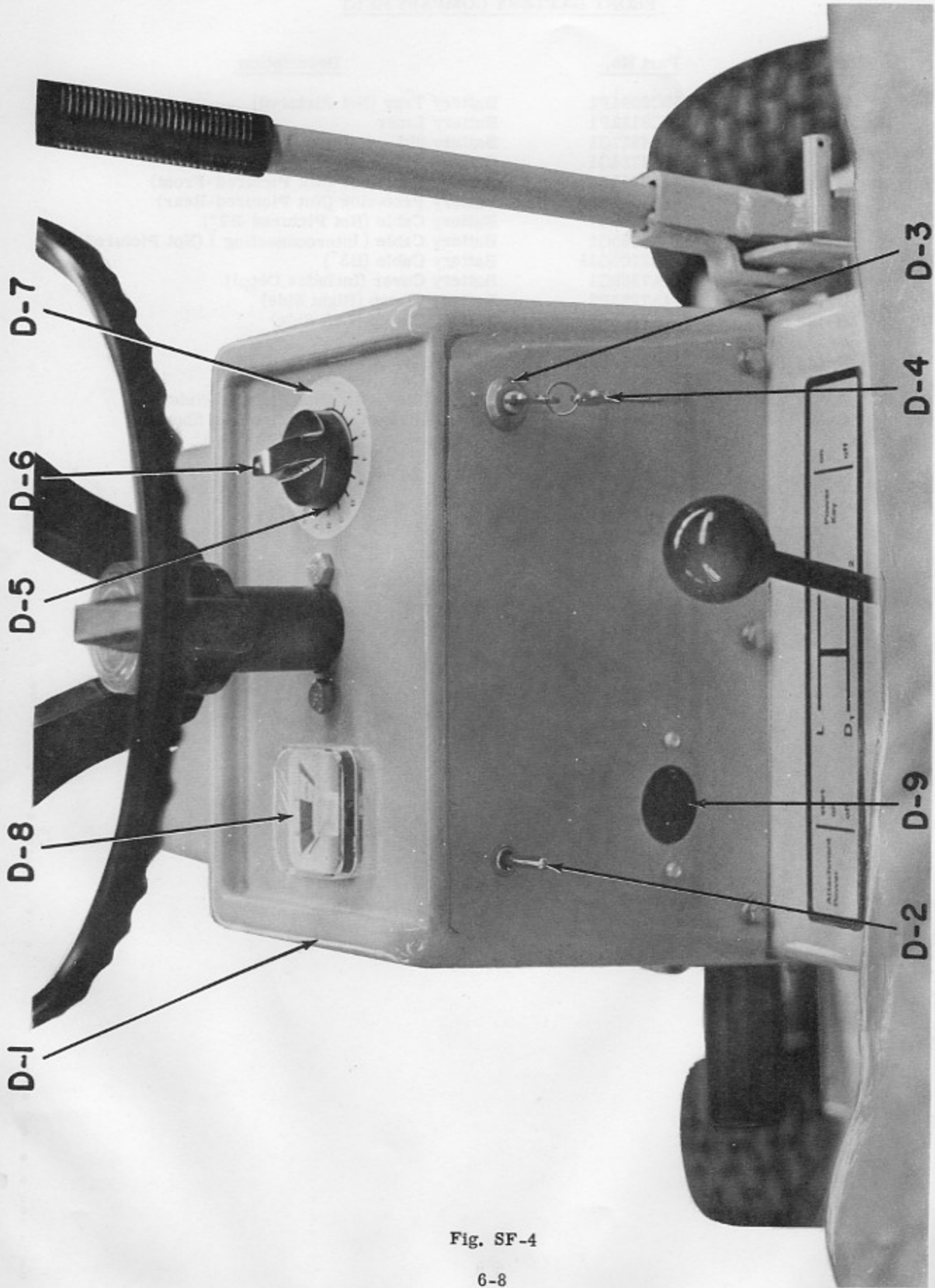

Fig. SF-4

DASH COMPONENTS

<u>Ref. No.</u>	<u>Part No.</u>	
D-1	127D8019P1	Dash Compartment (E10)
D-1	127D8019P2	Dash Compartment (E8)
D-2	244A7229P1	PTO Switch
D-3	244A7308P1	Key Switch
D-4	247A7354P1	Key
D-5	211A3507P1	Timer (All Models Except E8EA)
D-5	247A7484P1	Timer (E8EA Only)
D-6	243A4549P1	Timer Knob
D-7	244A7386P1	Timer Decal
D-8	243A4629G1	Fuel Level Gage (E10 Only)
D-9	243A4542P1	Accessory Outlet (E10 Only)
D-10	178B8238G1	Timer Assembly (All Models Except E8EA)
D-10	178B8238G2	Timer Assembly (E8EA Only)
D-11	211A3555G1	Cord Assembly (110 V a-c, not shown)
D-12	178B8246G1	Extension Cable (Not Shown - Jumper From Charger to Timer)

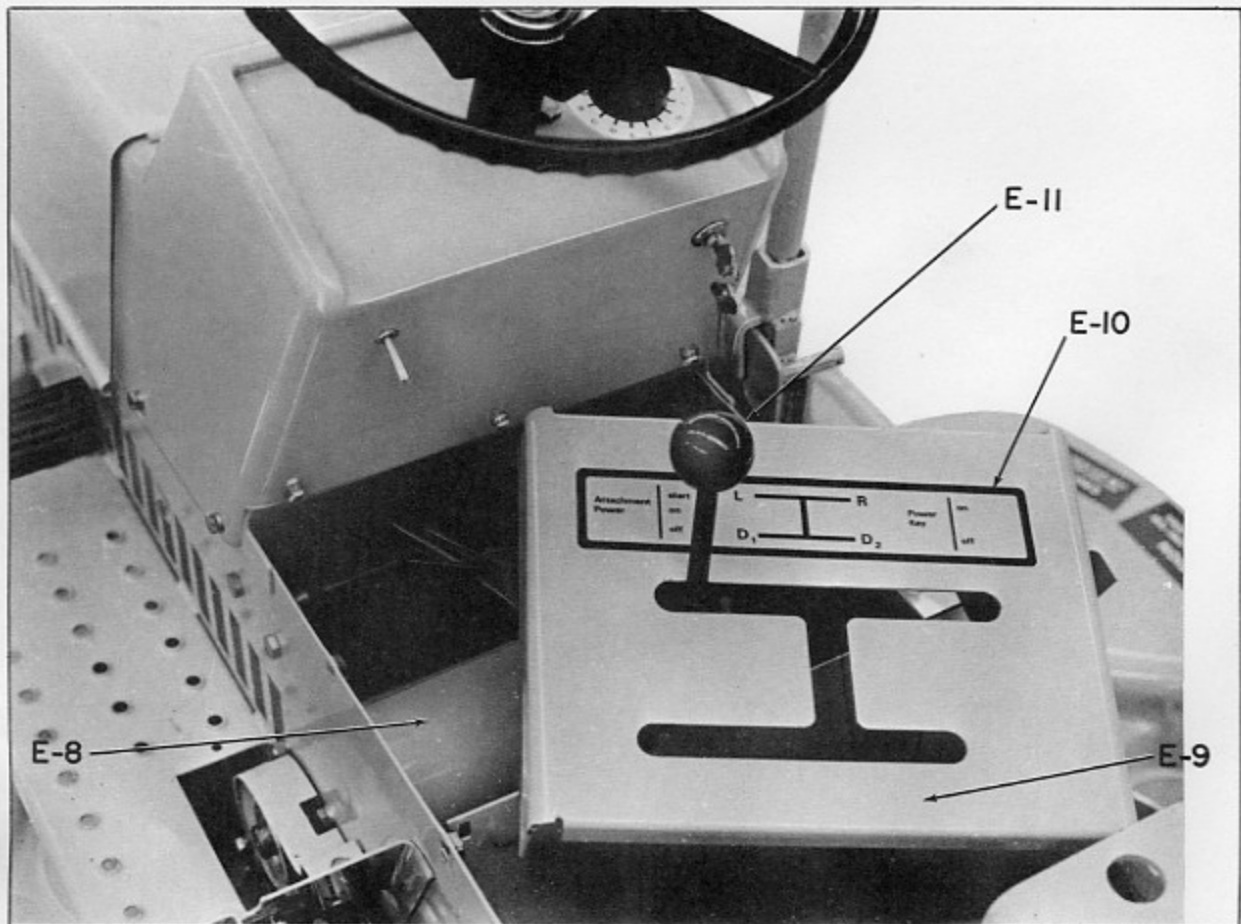
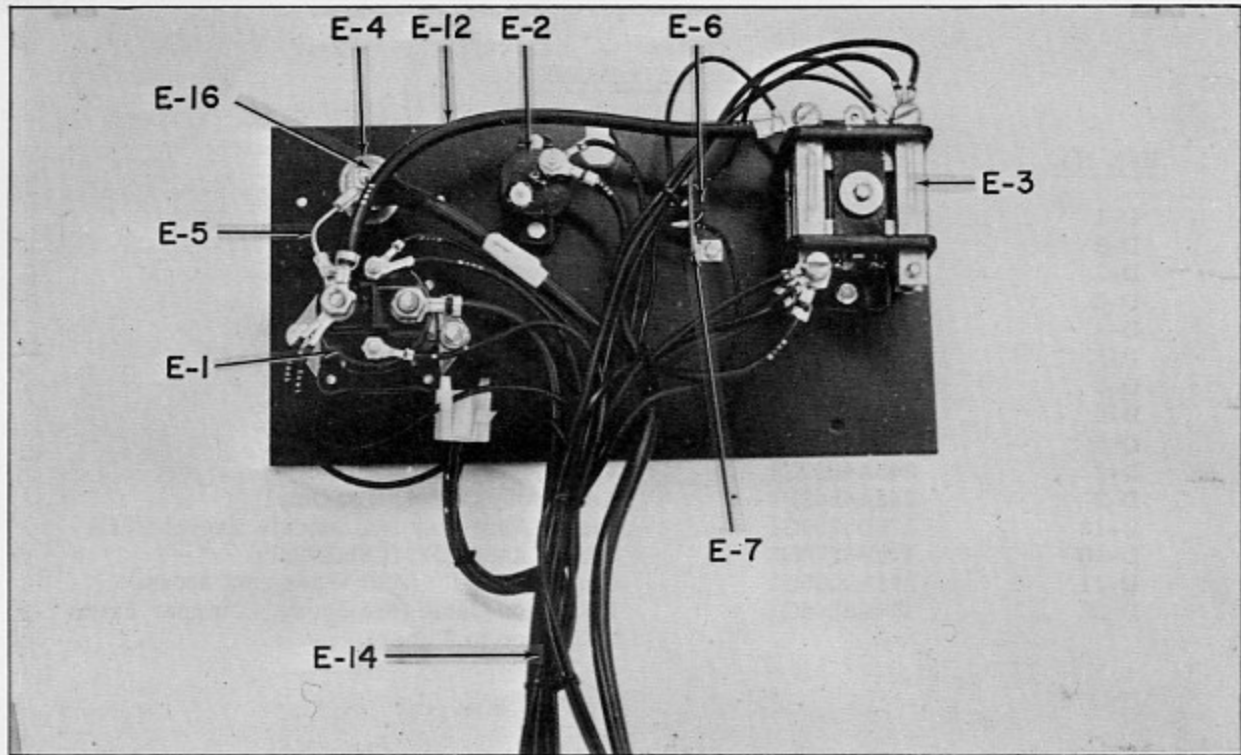

Fig. SF-5

ELECTRICAL COMPONENTS

<u>Ref. No.</u>	<u>Part No.</u>	<u>Description</u>
E-1	244A7063P1	L Contactor
E-2	243A4719P1	Circuit Breaker (CB-2)
E-3*	243A4524P1	P.T.O. Contactor (AA, BA, CA Models)
E-3*	178B8385P1	P.T.O. Contactor (DA + EA Models)
E-4	211A3165P1	Insulator
E-5	211A3448G2	Fusible Link
E-6	244A7326G2	Diode Asm. (All Models)
E-7	243A4953P1	Terminal Strip
E-8*	178B8244P1	Drive Motor (E10) (New) - 247A7750P2 (Factory Rebuilt)
E-8*	178B8216P1	Drive Motor (E8) (New) - 247A7750P1 (Factory Rebuilt)
E-9	155C8142P1	Motor Compartment Cover
E-10	178B8267P1	Shifting Decal
E-11	211A3249P3	Shifting Knob
E-12	244A7334G13	Connection Wire #1-01
E-13	243A4606P1	Circuit Breaker (CB-3, AA Models Only)
E-14*	127D8048G4	Cable Harness (AA, BA, CA Models)
E-14*	127D8079G1	Cable Harness (DA + EA Models)
E-15*	155C8136G1	Dash Harness (E10, AA Model) Not Shown
E-15*	155C8178G1	Dash Harness (E10, BA, CA, DA Models) Not Shown
E-15*	155C8132G1	Dash Harness (E8 Models) Not Shown
E-16	243A4658P1	Stud
E-17	243A4652P1	Diode (Not Shown)
E-8*	247A7750P1	Drive Motor E8 (Reconditioned)
E-8*	247A7750P2	Drive Motor E10 (Reconditioned)

\*When ordering this item it is imperative that care be taken to specify the model number and serial number of the tractor to insure your receiving the proper part.

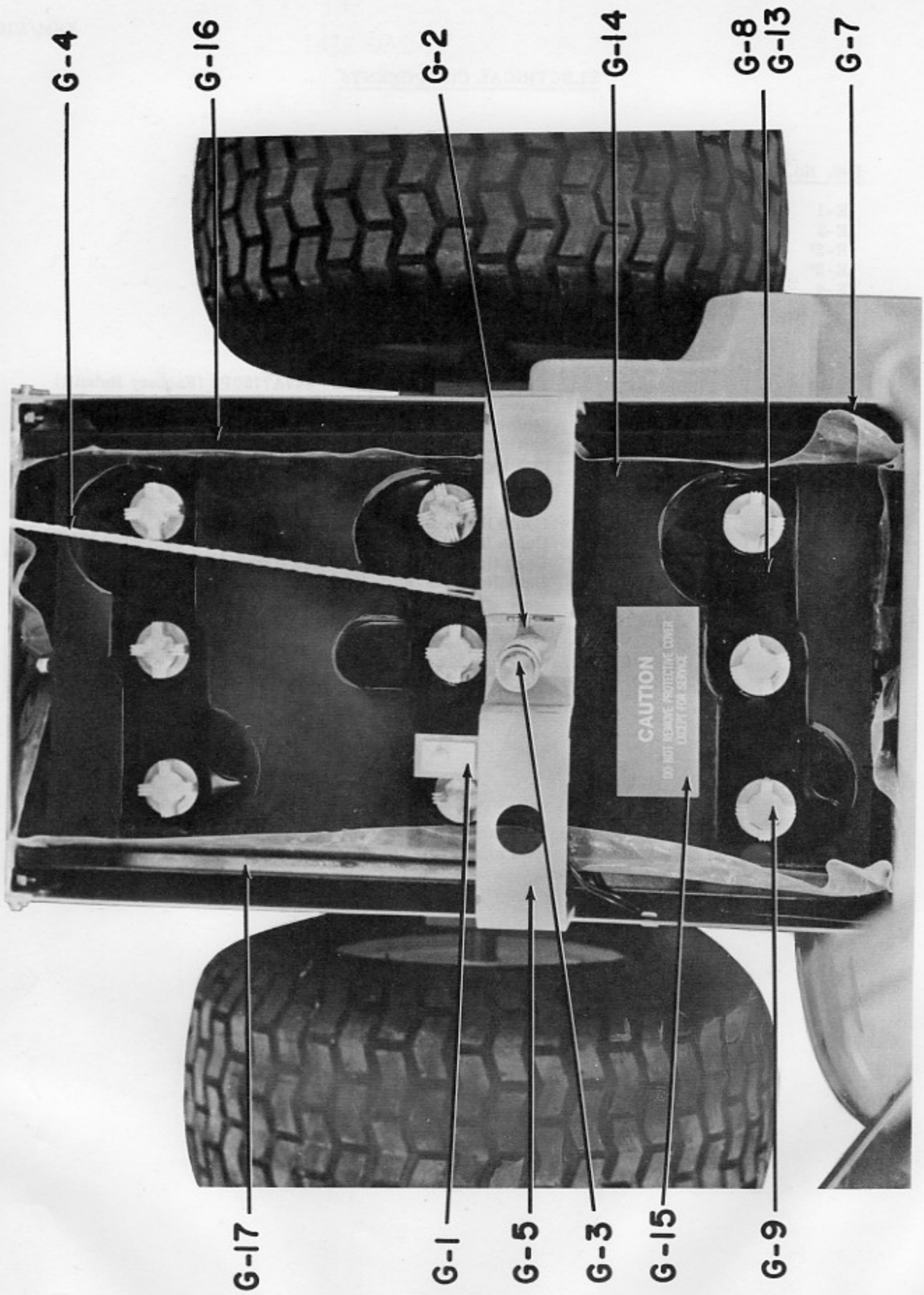

Fig. SF-6

REAR BATTERY COMPARTMENT

<u>Ref. No.</u>	<u>Part No.</u>	<u>Description</u>
G-1	243A4790P1	Seat Switch
G-2	211A3577P1	Seat Spring
G-3	211A3191P1	Rivet
G-4	244A7424G1	Line Asm.
G-5	244A7321G1	Seat Support Asm.
G-6	155C8094P1	Battery Tray (Not Pictured)
G-7	155C8122P1	Battery Liner
G-8	243A4527G1	Battery, Std.
G-8	243A4724G1	Battery, Hd.
G-9	243A4849P1	Battery Cap Old H. D.
G-9	243A4720P1	Battery Cap New H. D. + Standard
G-10	178B8165G11	Battery Cable (B4 <sup>+</sup> - Not Pictured)
G-11	178B8165G1	Battery Cable (Interconnecting, Not Pictured)
G-12	178B8165G8	Battery Cable (B5 <sup>-</sup> - Not Pictured)
G-13	244A7313P5	Battery Protector (Side)
G-14	247A7308G1	Battery Cover (Includes Decal)
G-16	244A7317P1	Battery Clamp (Left Side)
G-17	244A7317P2	Battery Clamp (Right Side)

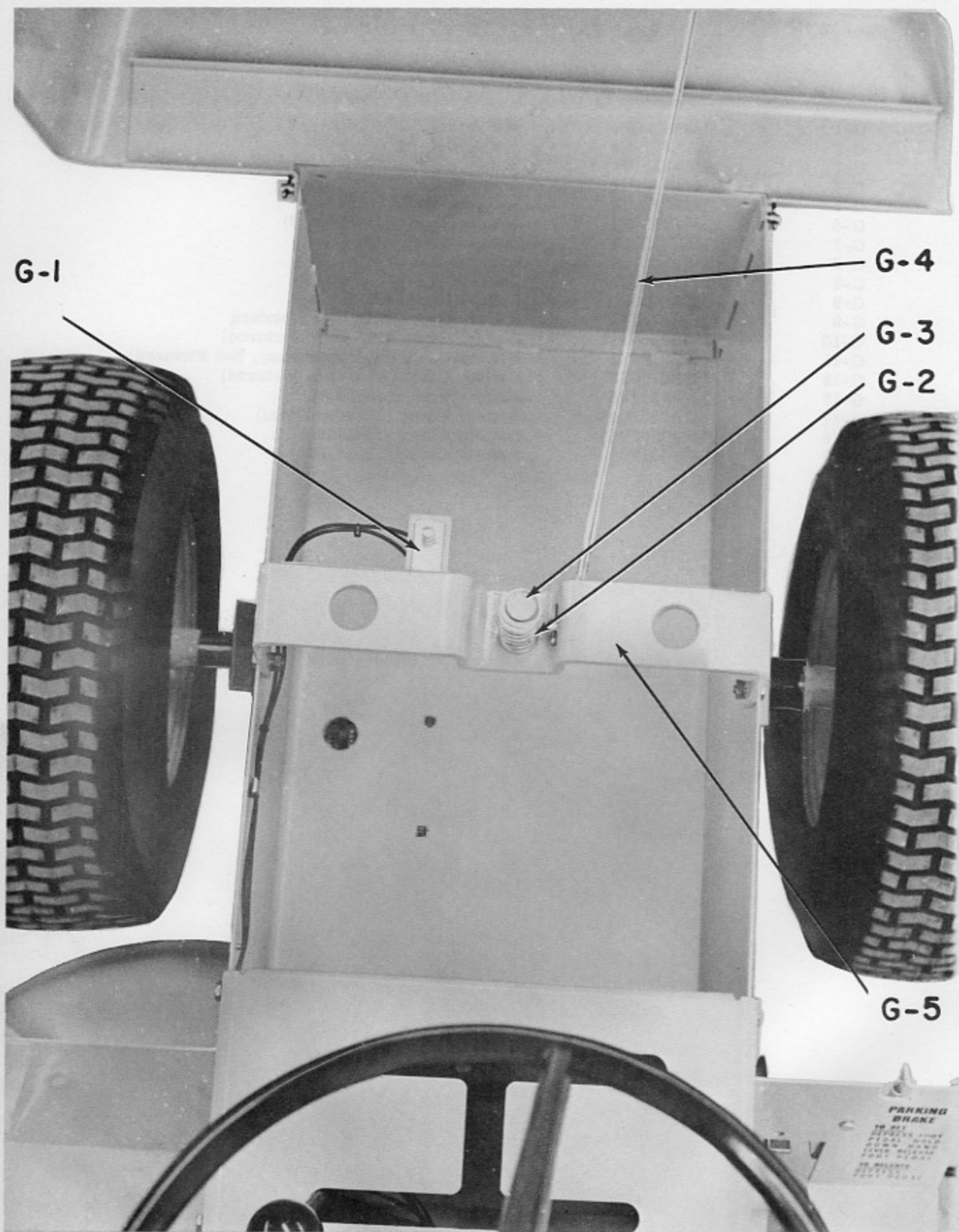

Fig. SF-7

REAR BATTERY COMPARTMENT

<u>Ref. No.</u>	<u>Part No.</u>	<u>Description</u>
G-1	243A4790P1	Seat Switch
G-2	211A3577P1	Seat Spring
G-3	211A3191P1	Rivet
G-4	244A7424G1	Line Asm.
G-5	244A7321G1	Seat Support Asm.
E8EA Heavy Duty (Not Pictured)		
G-6	155C8094P1	Battery Tray
G-7	155C8122P1	Battery Liner
G-8	178B8236G1	Battery (12 V)
G-9	244A7313P1	Battery Protector (Rear)
G-10	178B8165G10	Battery Cable (Interconnecting)
G-11	247A7307G1	Battery Cover
G-12	178B8476P1	Battery Clamp (Right)
G-13	178B8476P2	Battery Clamp (Left)
G-14	247A7504P1	Hold Down Stud
G-15	N405P11C6	Lockwasher - 1/4"
G-16	N210P21B6	Hex Nut - 1/4" -20
G-17	247A7496G1	Battery Cap

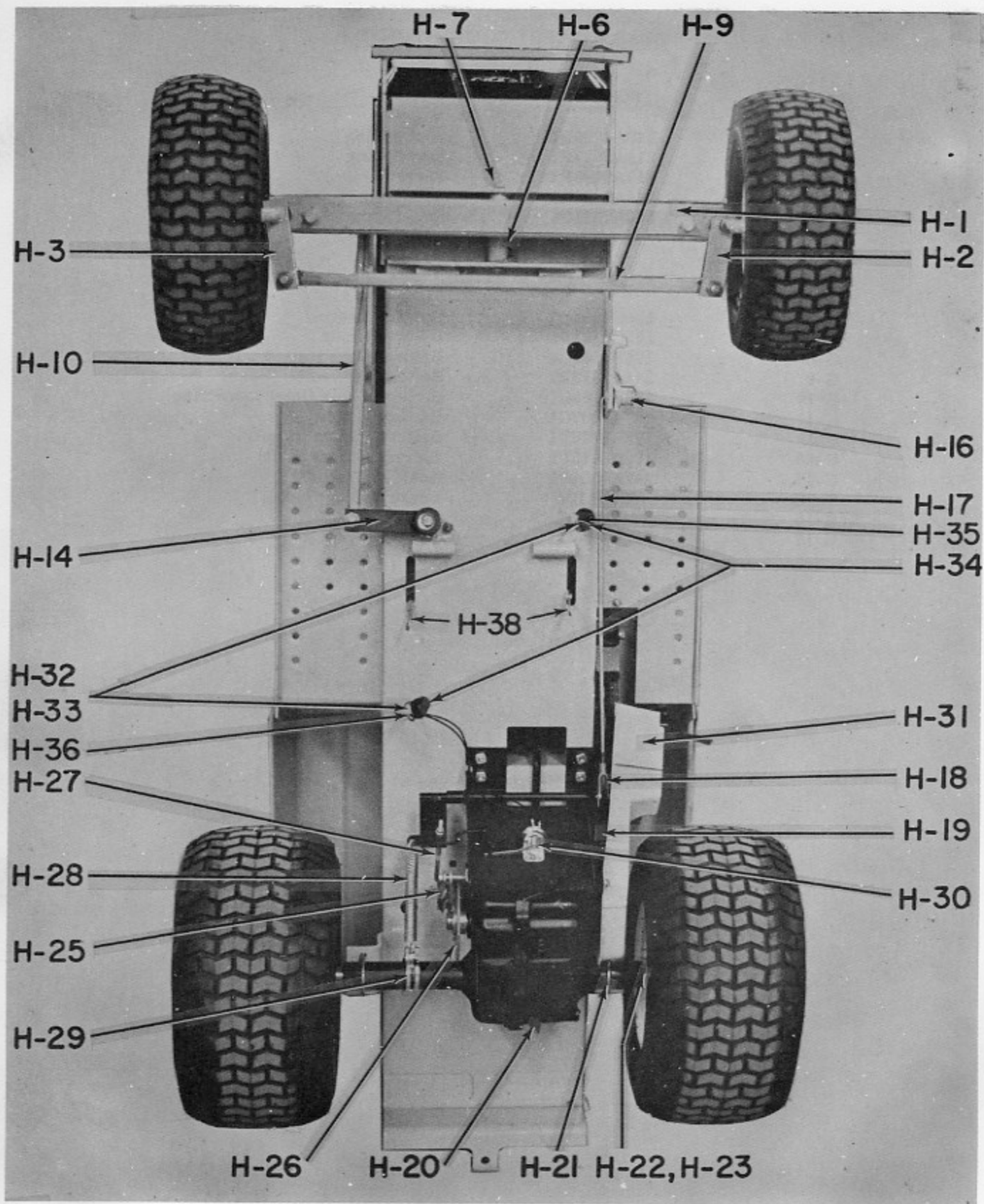

Fig. SF-8

UNDERCARRIAGE COMPONENTS

<u>Ref. No.</u>	<u>Part No.</u>	<u>Description</u>
H-1	178B8032G1	Front Axle
H-2	178B8282G1	Spindle, Left
H-3	178B8217G1	Spindle, Right
H-4	243A4587P1	Thrust Washer (Located on Spindle)
H-5	N922P75C6	Snap Ring (Located at Top of Spindle) - 3/4"
H-6	243A4867P1	Grease Fitting
H-7	244A7416P1	Pivot Pin
H-8	N922P62C6	Retaining Ring for Pivot Pin - 5/8"
H-9	178B8203P1	Tie Rod
H-10	178B8203P2	Tie Rod
H-11	244A7180G1	Steering Arm Asm. (Top of Right Spindle)
H-12	N3400P606	Key (3/16 x 3/4 Woodruff)
H-13	N72P2108B6	Set Screw (1/4-20 x 1/2)
H-14*	244A7183G1	Steering Arm Asm. - Use Pt. 13 and 15 (All E8's & E10's except below)
H-14*	178B8402G1	Steering Arm Asm. - Use Pt. 37 (E10 DA, EA)
H-15	N3400P405	Key (1/8 x 5/8 Woodruff)
H-16	243A4554P3	Push Nut
H-17	244A7126P2	Rod
H-18	244A7168P1	Clevis
H-19	178B8262G1	Torque Plate
H-20	127D8015P1	Transaxle (Peerless 1216)
H-21	244A7234P1	U-Bolt
H-22	244A7221P1	Clevis Pin (Wheel)
H-23	N503P1516B6	Cotter Pin (Wheel) 5/32" x 1"
H-24	244A7295P1	Transaxle Sheave (Not Pictured)
H-25	155C8149G1	Brake Assembly
H-26	244A7301G1	Disk and Hub
H-27	244A7409P1	Brake Rod
H-28	244A7415P1	Return Spring
H-29	244A7404P1	Strap
H-30	211A3481P1	Clutch Switch
H-31	155C8126P1	Belt Guard
H-32	243A4596P1	Mower Socket Housing
H-33	243A4552P1	Contact Pins
H-34	211A3589P4	Grommet
H-35	191B4548G2	Replacement Lead Kit (7-01-7, 8-01-8) - Left
H-36	191B4548G3	Replacement Lead Kit (7-02-7, 8-02-8) - Right
H-37	N533P2524	Spring Dowel Pin 1/4" x 1 1/2"
H-38	244A7185P1	Lift Cable

\*When ordering this item it is imperative that care be taken to specify the model number and serial number of the tractor to insure your receiving the proper part.

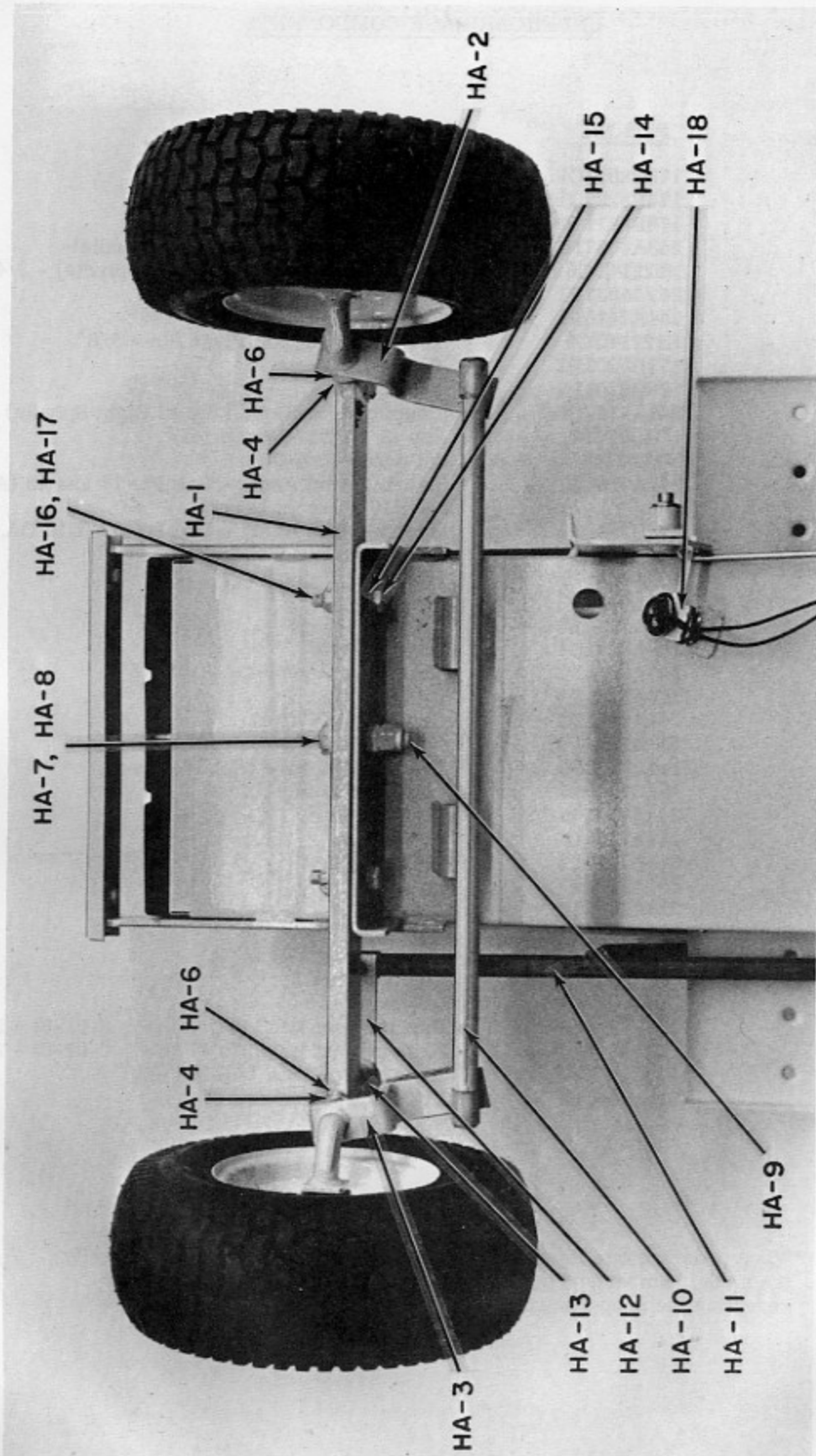

Fig. SF-9

UNDERCARRIAGE COMPONENTS

<u>Ref. No.</u>	<u>Part No.</u>	<u>Description</u>
HA-1	178B8215G1	Front Axle
HA-2	178B8449G1	Spindle (Left)
HA-3	178B8448G1	Spindle (Right)
HA-4	243A4587P1	Thrust Washer
HA-5	N922P75C6	Snap Ring (On Spindle) - 3/4"
HA-6	247A7301P1	Grease Fitting
HA-7	N22P33040B6	Bolt - (5/8-11 x 2 1/2") - self locking
HA-8	244A7469P1	Bearing
HA-9	247A7466P1	Lock Nut
HA-10	178B8203P1	Tie Rod
HA-11	178B8203P2	Tie Rod
HA-12	178B8409G1	Steering Arm Asm. (Top of Right Spindle)
HA-13	N533P2524	Spring Dowel Pin (Top of Right Spindle) 1/4" x 1 1/2"
HA-14	N22P29032B6	Hex Head Bolt - (1/2 - 13 x 2") self locking
HA-15	247A7494P1	Flanged Bearing
HA-16	N405P15C6	Lock Washer - (1/2")
HA-17	N258P29B6	Hex Nut (1/2" - 13)
HA-18	211A3481P1	Clutch Switch
HA-19	178B8342G2	Complete Axle Assembly (Includes HA-1 through HA-6, HA-10, HA-12, HA-13 and HA-16)

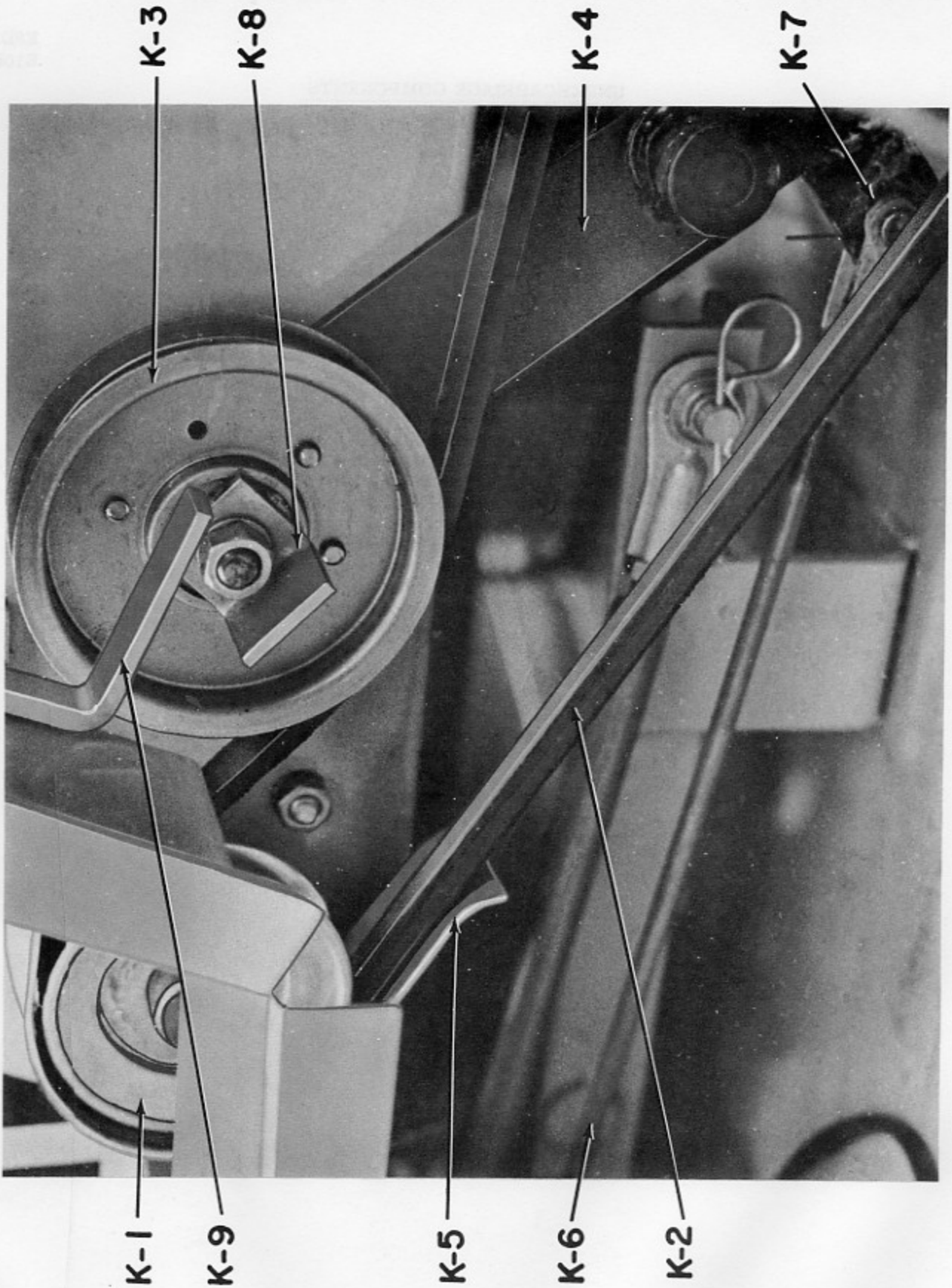

Fig. SF-10

DRIVE ASM.

<u>Ref. No.</u>	<u>Part No.</u>	<u>Description</u>
K-1	247A7394P1	Motor Sheave (Replaces 244A7329P1)
K-2	211A3226P11	Drive Belt
K-3	244A7318P1	Idler Pulley
K-4	244A7407G1	Idler Arm Asm.
K-5	244A7278G1	Belt Retainer Asm.
K-6	244A7126P2	Rod
K-7	244A7168P1	Clevis
K-8	244A7369P1	Parking Brake Angle
K-9	178B8237P1	Hand Parking Brake
K-10	244A7466P1	Hand Grip (For Parking Brake)
K-11	244A7319P1	Spring, Parking Brake (Not Shown)



TABLE OF CONTENTS

<u>FIGURE</u>	<u>TITLE</u>
E16-1	Body Components
E16-2	Dash Components
E16-3	Electrical Components
E16-4	Speed Control

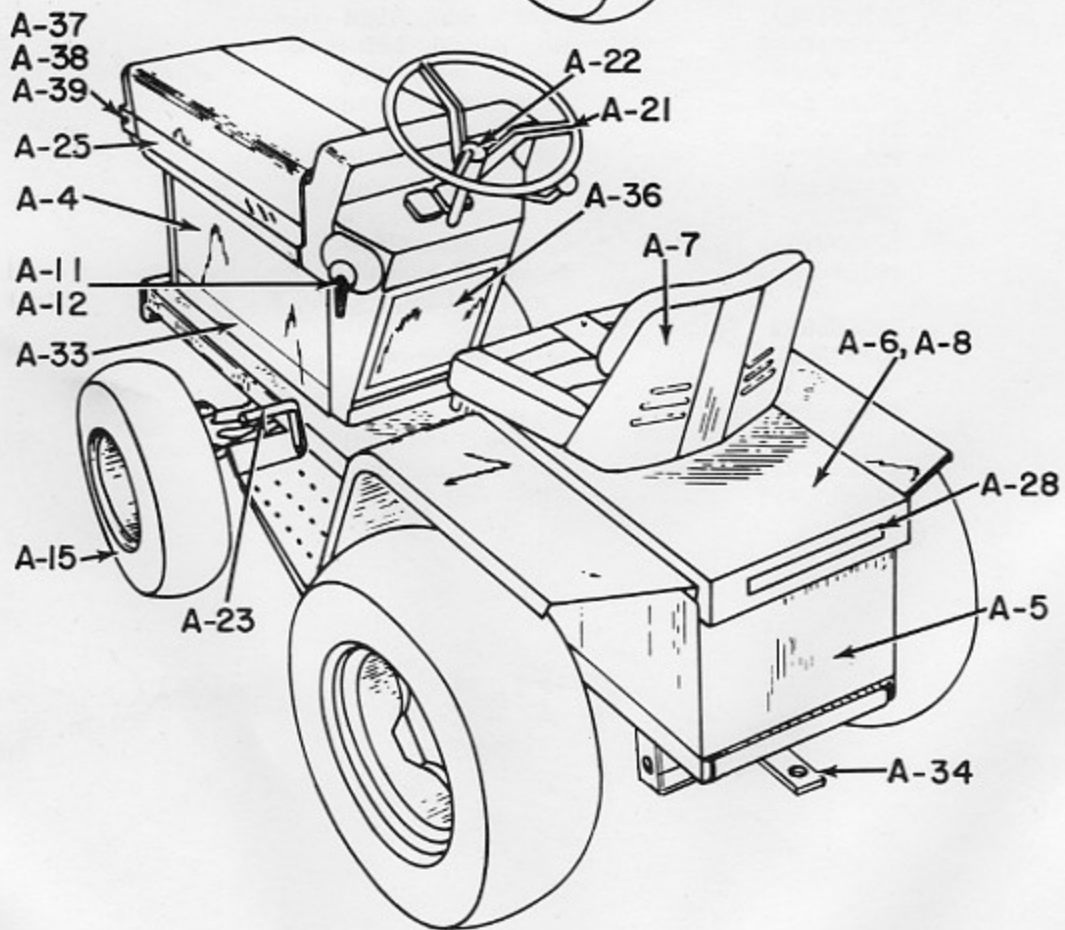
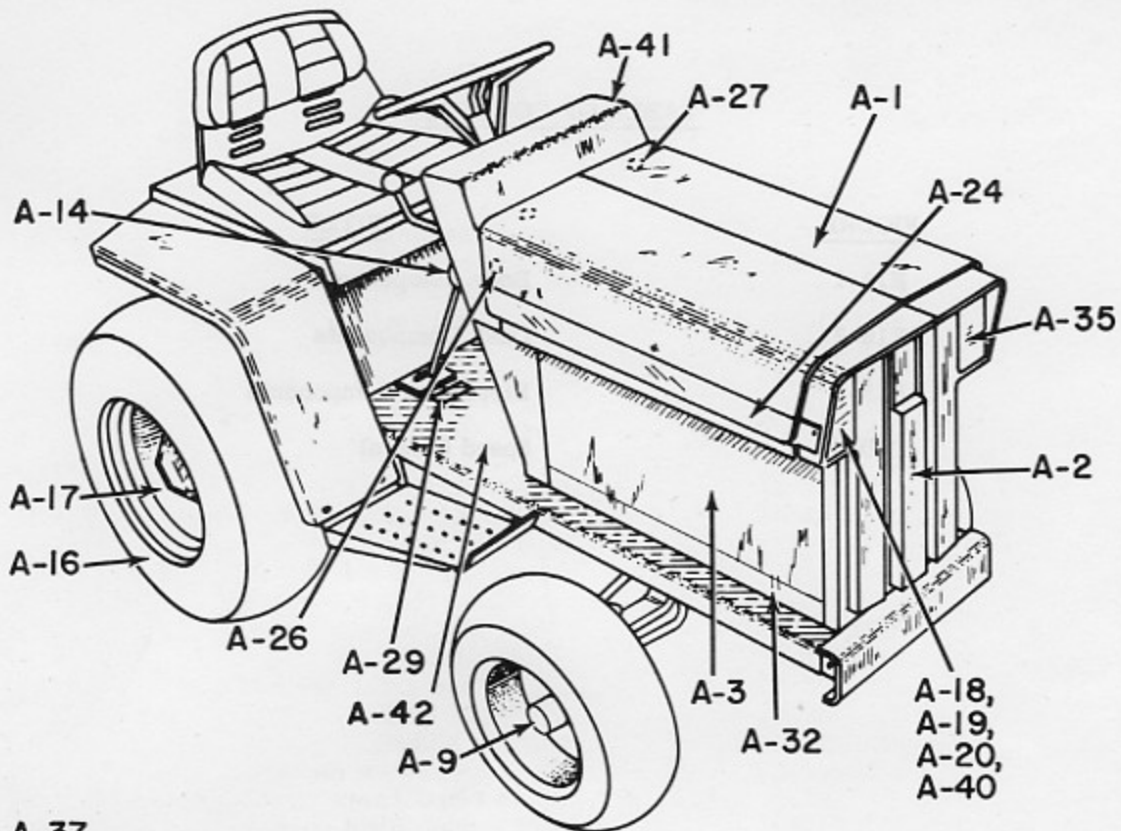

Fig. E16-1

BODY COMPONENTS

<u>Ref. No.</u>	<u>Part No.</u>	<u>Description</u>
A-1	178B8492G1	Hood Assembly
A-2	423D214P2	Front Grill
A-3	422D837P3	Side Body Panel, Right
A-4	422D838P3	Side Body Panel, Left
A-5	423D221G3	Rear Battery Box Assy. (Includes Fenders)
A-6	541C937G8	Rear Battery Box Cover (less Seat)
A-7	247A7442G2	Seat Assembly
A-8	243A4789P1	Seat Stiffener
A-9	247A7649P1	Dust Cap
A-11	178B8137G1	Power Disconnect
A-12	211A3448G1	Fusible Link (Located on Power Disconnect)
A-14	211A3249P3	Gearshift Knob
A-15	541C951G1	Front Tire (16 x 4.80/4.00-8) & Rim
A-16	541C658G2	Rear Tire (23 x 9.50-12) & Rim
A-17	243A4589P1	Wheel Lug
A-18	211A3413P1	Headlight Lens
A-19	163B9936G1	Reflector & Light Assembly
A-20	211A3592P1	Lamp (GE 1076)
A-21	423D255P1	Steering Wheel
A-22	243A4828G1	Cap & Monogram Assy.
A-23		Brake Pedal Assembly (See Section 10)
A-24	127D8143P1	Hood Decal, Right Hand
A-25	127D8143P2	Hood Decal, Left Hand
A-26	243A4639P1	Hood Rubber Bumper (Mounted on Both Sides)
A-27	243A4639P2	Hood Rubber Bumper (Mounted on Top)
A-28	211A3250P1	Rear Tail Reflector
A-29	247A7473P1	Decal, "To Facilitate Shifting"
A-32	127D8095P3	Elec-Trak Insignia RH
A-33	127D8095P4	Elec-Trak Insignia LH
A-34	163B9919P1	Convenience Hitch
A-35	163B9878G1	Headlight Assembly (Includes Reflector and Light Asm., Lamp, Lens, Hardware and Spacer)
A-36	542C868P2	Cover
A-37	243A4588P1	Machine Screw
A-38	211A3424P1	Bushing
A-39	243A4576P2	Washer
A-40	243A4550P4	Spacer (Headlight)
A-41	423D260P5	Control Cabinet
A-42	247A7802P1	Floor Mat

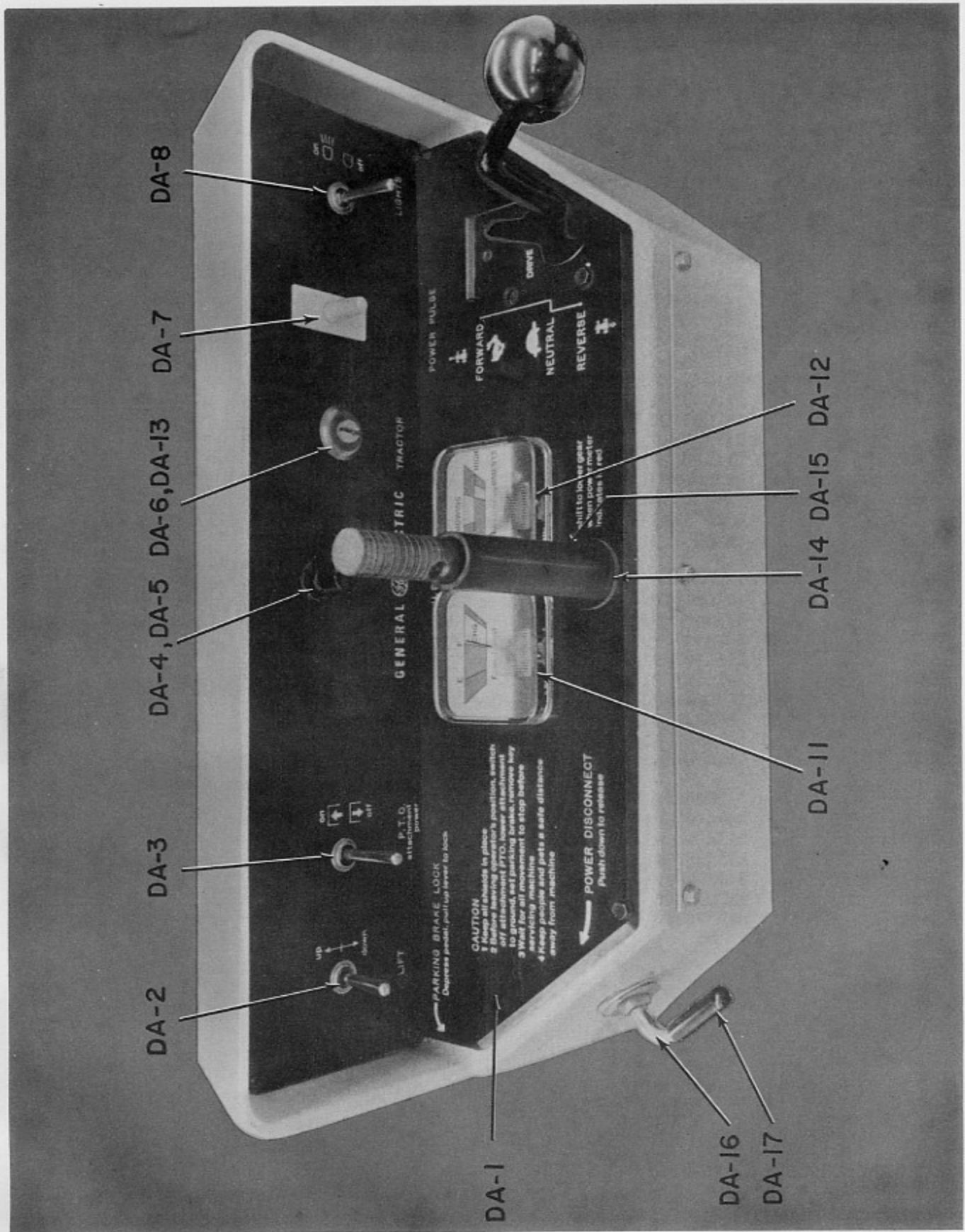

Fig. E16-2

DASH COMPONENTS

<u>Ref. No.</u>	<u>Part No.</u>	<u>Description</u>
DA-1	127D8106P2	Dash Panel
DA-2	243A4531P2	Lift Switch
DA-3	244A7229P1	P. T. O. Switch
DA-4	243A4574P1	Light, Dash
DA-5	211A3591P1	Lamp
DA-6	244A7308P1	Key Switch
DA-7	247A7455P1	Power Pulse Switch
DA-8	243A4531P3	Light Switch
DA-9	158C9052G1	Dash Harness
DA-10	211A3551P1	Tubing (Not Pictured - Insulation on Switch Terminal)
DA-11	243A4629G1	Fuel Level Gage
DA-12	243A4630G4	Power Use Gage
DA-13	247A7354P1	Key
DA-14	243A4576P3	Washer
DA-15	243A4809P2	Sleeve
DA-16	178B8137G1	Power Disconnect (Includes Hand Grip)
DA-17	244A7089P1	Hand Grip

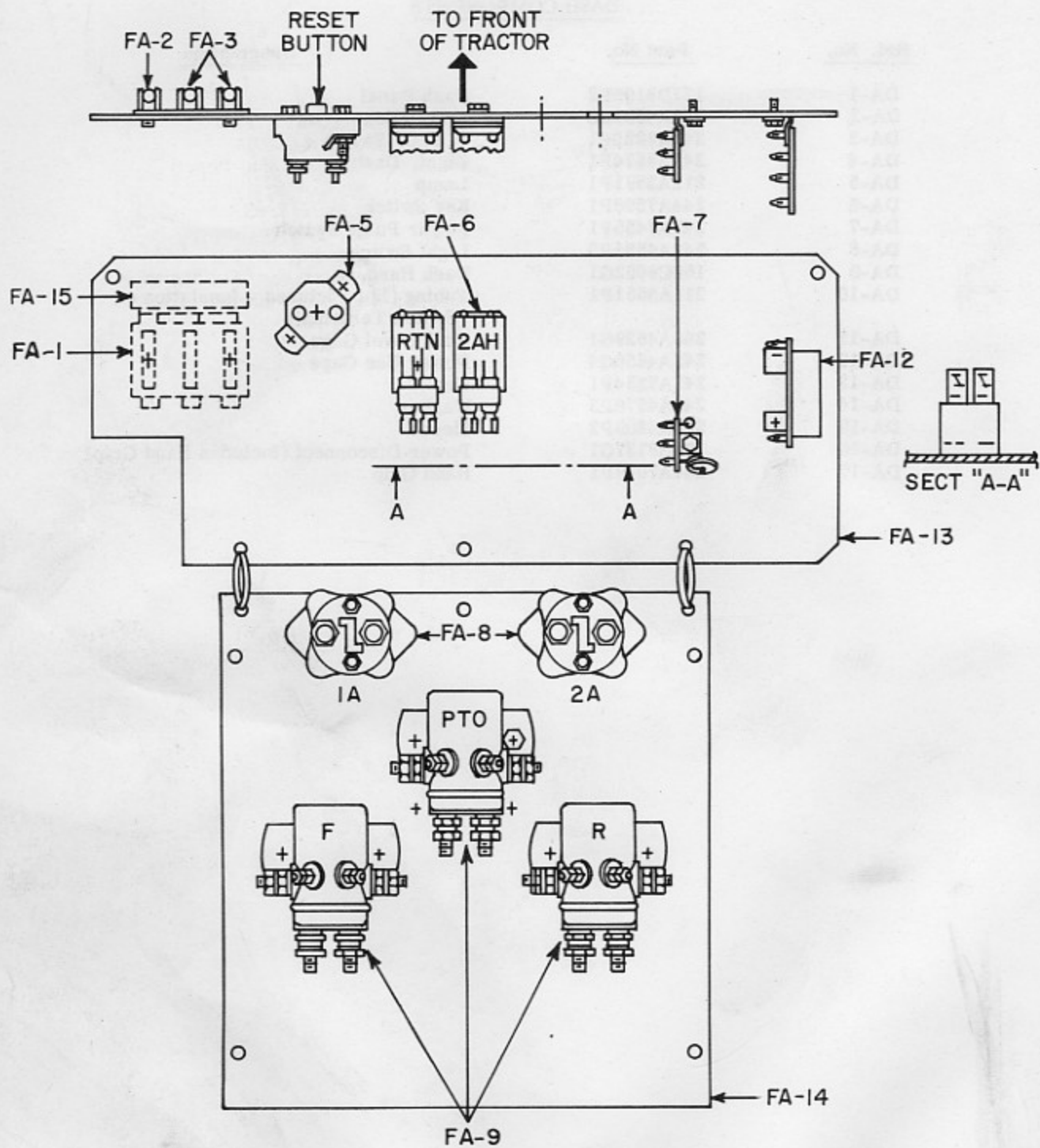

Fig. E16-3

ELECTRICAL COMPONENTS

<u>Ref. No.</u>	<u>Part No.</u>	<u>Description</u>
FA-1	244A7463P1	Fuse Block
FA-2	243A4597P1	Fuse 30 Amp Slo Blo, FU2
FA-3	243A4657P1	Fuse 20 Amp, FU3, FU4
FA-5	243A4719P1	Circuit Breaker (Manual Reset)
FA-6	243A4562P1	Relay (Rtn, 2AH)
FA-7	178B8457G3	Diode and Varistor Asm.
FA-8	247A7462P1	Contactor (1A, 2A)
FA-9	178B8385P1	Contactor (P. T. O., F. R.)
FA-10	127D8112G1	Control Panel Harness (Not Shown)
FA-11	158C9064G2	Control Panel Adder Harness (Not Shown)
FA-12	178B8459G1	Field Resistor Asm.
FA-13	178B8444P1	Upper Control Panel
FA-14	178B8445P1	Lower Control Panel
FA-15	211A3523P1	Fuse Decal

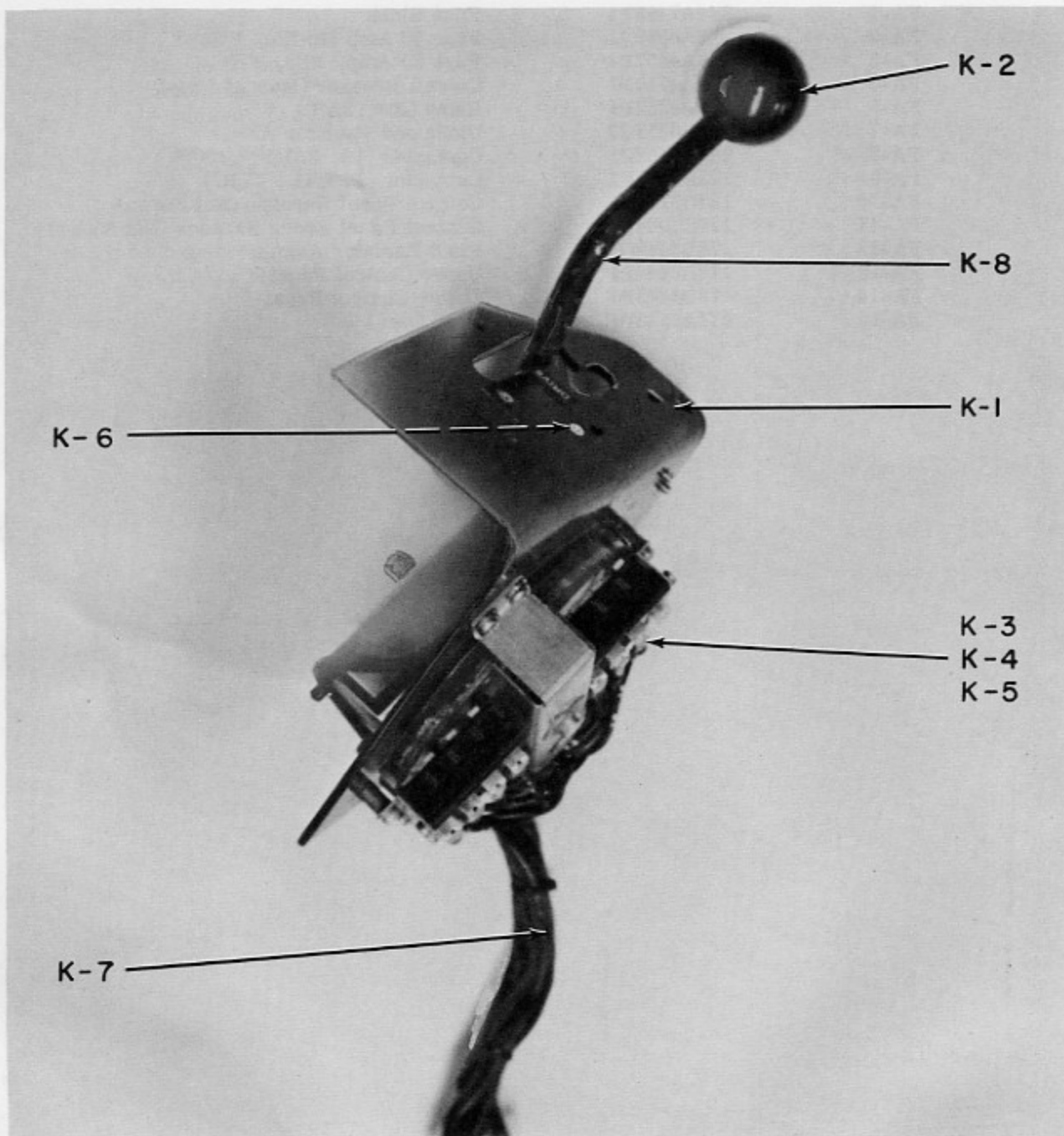

Fig. E16-4

SPEED CONTROL

<u>Ref. No.</u>	<u>Part No.</u>	<u>Description</u>
K-1	423D213G6	Speed Control
K-2	211A3249P1	Speed Control Knob
K-3	211A3198P1	Start Switch, 3 Tabs, N. O. N. C. and Common
K-4	211A3198P2	1A, 2A Switch, 2 Tabs, N. O. and Common
K-5	211A3198P3	FW, 1-4, 2 Tabs, ;N. C. and Common
K-6	211A3558P2	Reverse Switch
K-7	158C9051G2	Throttle Harness
K-8	211A3239G1	Lever

NOTE: Roll Pin connecting throttle lever to cam shaft must be replaced by clevis pin, Part No. 247A7830P1, and cotter pin, Part No. N503P312 1/32 x 3/4 LG. to improve throttle assembly.



TABLE OF CONTENTS

<u>FIGURE</u>	<u>TITLE</u>
E14-1	Body Components
E14-2	Dash Components
E14-3	Electrical Components (E14RC, RD, RH)
E14-4	Electrical Components (E14AA, RJ)
E14-5	Speed Controls

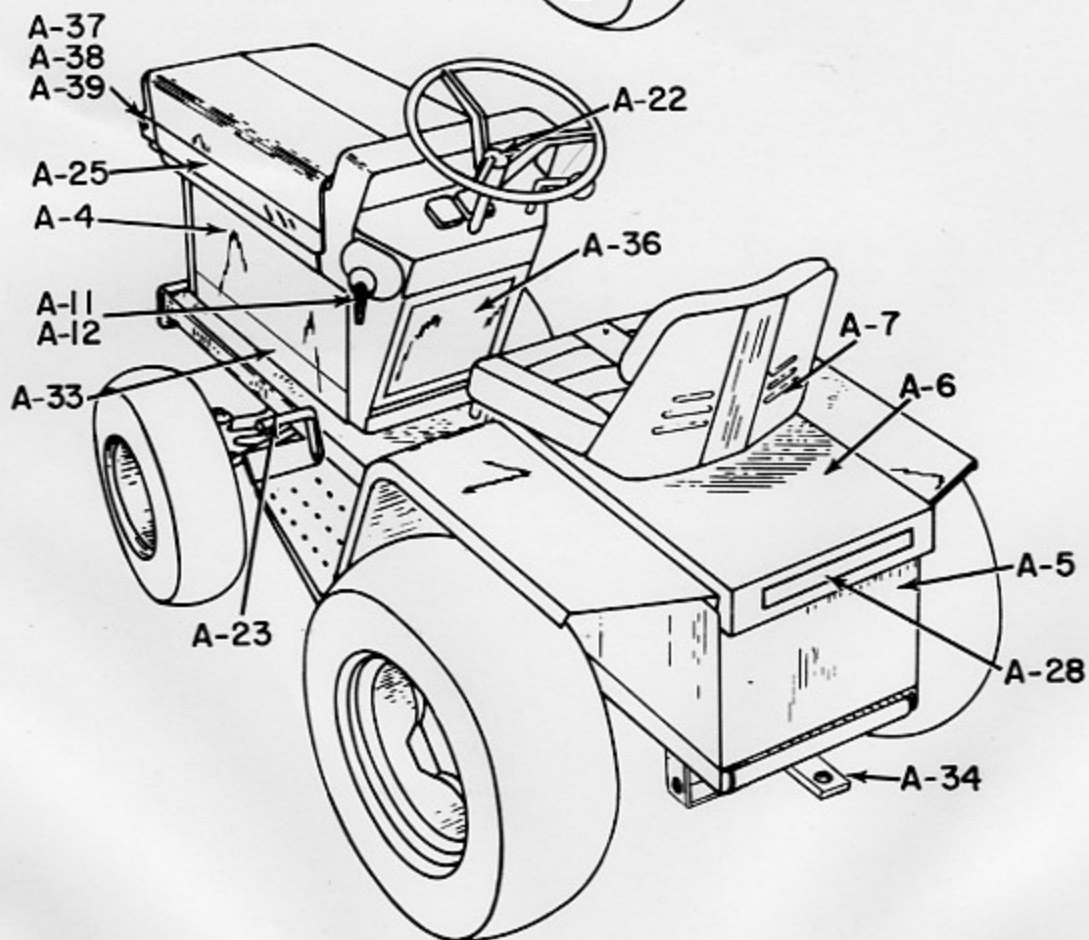
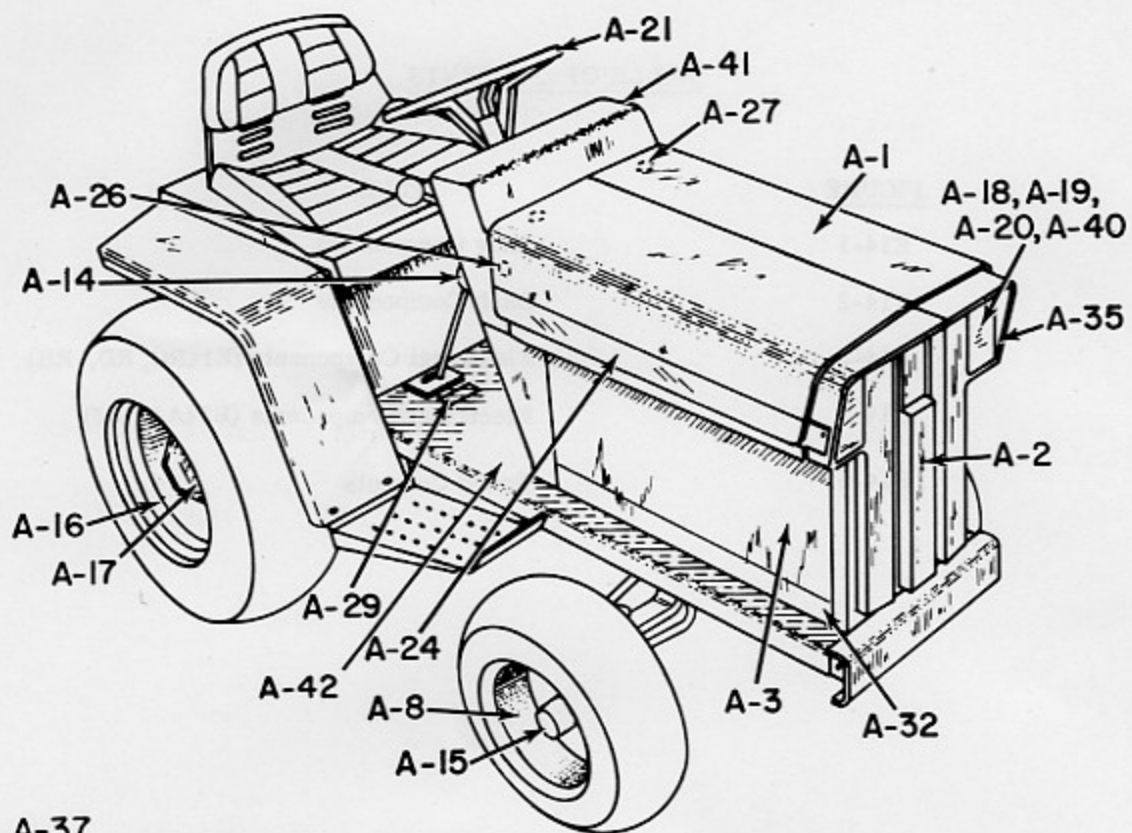

Fig. E14-1

BODY COMPONENTS

<u>Ref. No.</u>	<u>Part No.</u>	<u>Description</u>
A-1	178B8492G1	Hood Assembly
A-2	423D214P2	Front Grill
A-3	422D837P3	Side Body Panel, Right
A-4	422D838P3	Side Body Panel, Left
A-5	423D221G3	Rear Battery Box Assembly, (Includes Fenders)
A-6	541C937G8	Rear Battery Box Cover (Less Seat)
A-7*	247A7442G2	Seat
A-8	247A7649P1	Dust Cap
A-11	178B8137G1	Power Disconnect
A-12	211A3448G1	Fusible Link (Located on Power Disconnect)
A-14	211A3249P3	Gearshift Knob
A-15	541C951G1	Front Tire (16 x 4.80/4.00-8) and Rim
A-16	541C658G1	Rear Tire (23 x 8.50-12) and Rim
A-17	243A4589P1	Wheel Lug
A-18	211A3413P1	Headlight Lens
A-19	163B9936G1	Reflector and Light Assembly
A-20	211A3592P1	Lamp (GE 1076)
A-21	423D255P1	Steering Wheel
A-22	243A4828G1	Cap and Monogram Assembly
A-23		Brake Pedal Assembly (See Section 10)
A-24	127D8093P1	Hood Decal, Right Hand
A-25	127D8093P2	Hood Decal, Left Hand
A-26	243A4639P1	Hood Rubber Bumper (Mounted on Both Sides)
A-27	243A4639P2	Hood Rubber Bumper (Mounted on Top)
A-28	211A3250P1	Rear Tail Reflector
A-29	247A7473P1	Decal to Facilitate Shifting
A-32	127D8095P3	Elec-Trak Insignia RH
A-33	127D8095P4	Elec-Trak Insignia LH
A-34	163B9919P1	Conv. Hitch
A-35	163B9878G1	Headlight Assembly (Includes Reflector and Light Assm., Lamp, Lens, Hardware and Spacer)
A-36	542C868P2	Cover
A-37	243A4588P1	Machine Screw
A-38	211A3424P1	Bushing
A-39	243A4576P2	Washer
A-40	243A4550P4	Spacer (Headlight)
A-41	423D260P5	Control Cabinet
A-42	247A7802P1	Floor Mat

## \*Consists of:

243A4770P1	Seat Pan
178B8030P1	Cushion Bottom
243A4852P1	Cushion Rear (Non-Adj.)

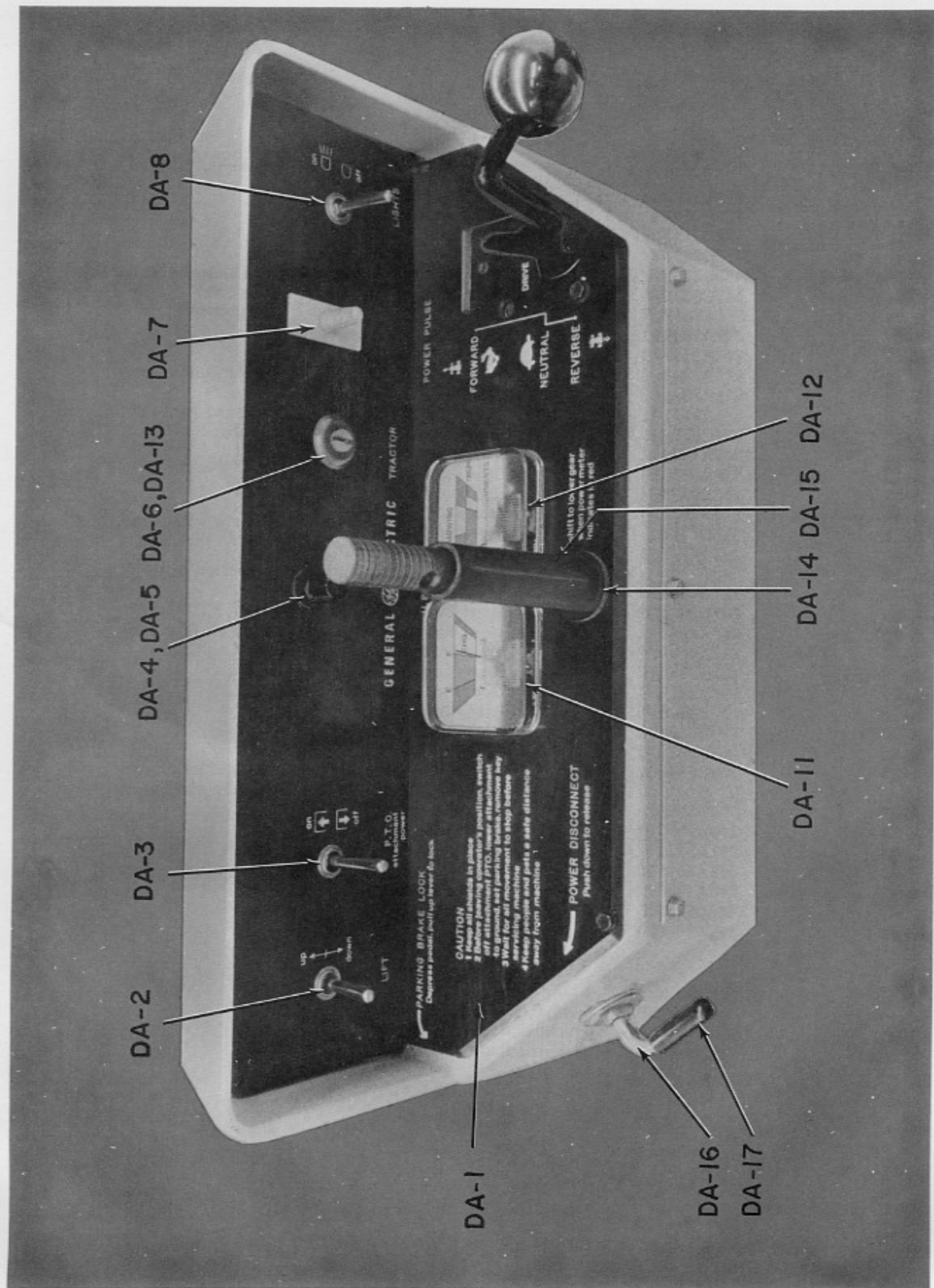

Fig. E14-2

DASH COMPONENTS

<u>Ref. No.</u>	<u>Part No.</u>	<u>Description</u>
DA-1	127D8106P2	Dash Panel
DA-2	243A4531P2	Lift Switch
DA-3	244A7229P1	P. T. O. Switch
DA-4	243A4574P1	Light, Dash
DA-5	211A3591P1	Lamp
DA-6	244A7308P1	Key Switch
DA-7	247A7455P1	Power Pulse Switch
DA-8	243A4531P3	Light Switch
DA-9	158C9052G1	Dash Harness
DA-10	211A3551P1	Tubing (Not Pictured - Insulation on Switch Terminal)
DA-11	243A4629G1	Fuel Level Gage
DA-12	243A4630G4	Power Use Gage
DA-13	247A7354P1	Key
DA-14	243A4576P3	Washer
DA-15	243A4809P2	Sleeve
DA-16	178B8137G1	Power Disconnect (Includes Hand Grip)
DA-17	244A7089P1	Hand Grip

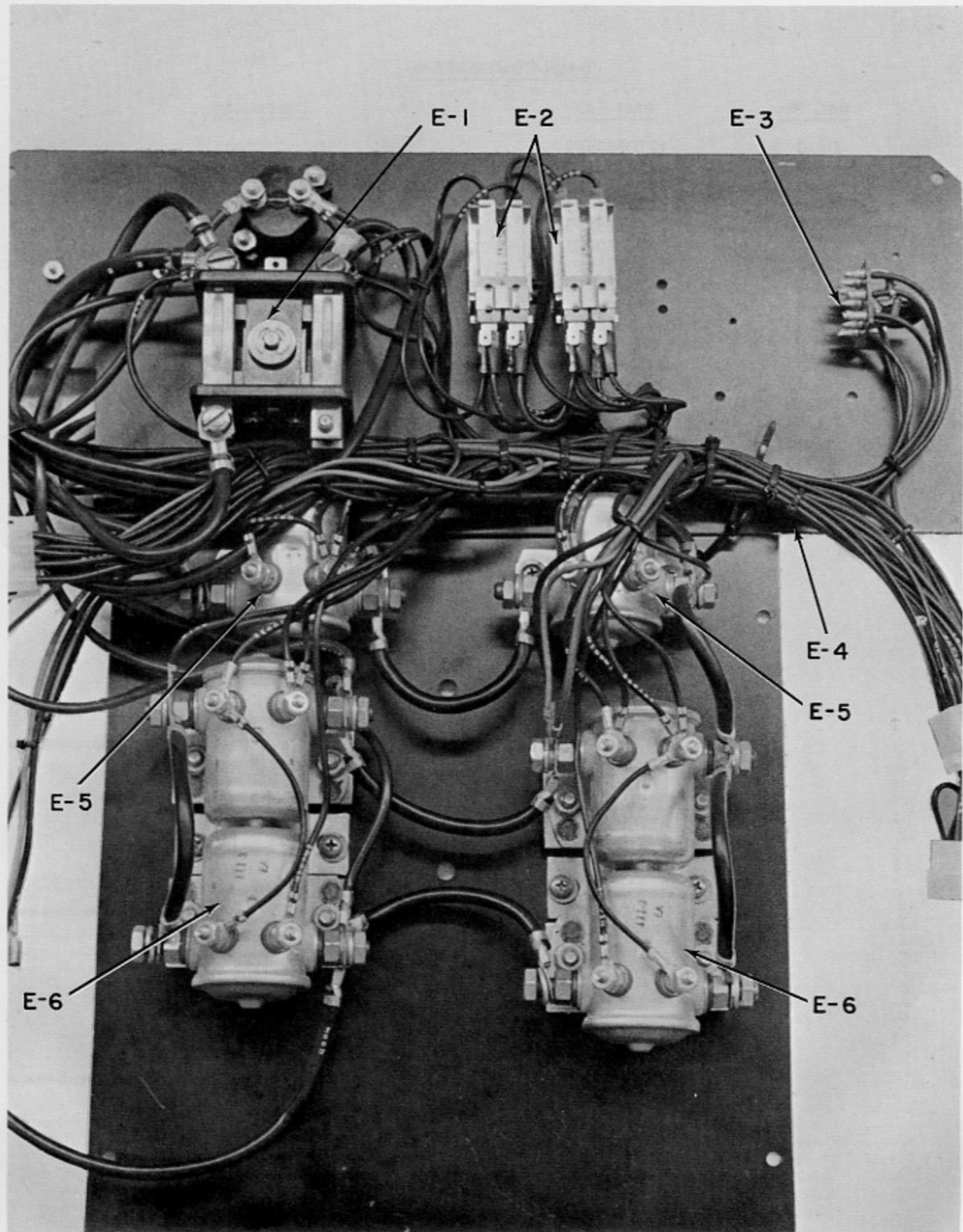

Fig. E14-3

6B-6

ELECTRICAL COMPONENTS  
(Upper Control Panel)

<u>Ref. No.</u>	<u>Part No.</u>	<u>Description</u>
E-1	243A4524P1	P. T. O. Contactor
E-2	243A4562P1	Relay
E-3	243A4970G1	Diode and Varistor Assembly
E-4	423D229G1	Control Panel Harness
E-5	211A3567P1	Contactor
E-6	178B8009P1	Double Contactor

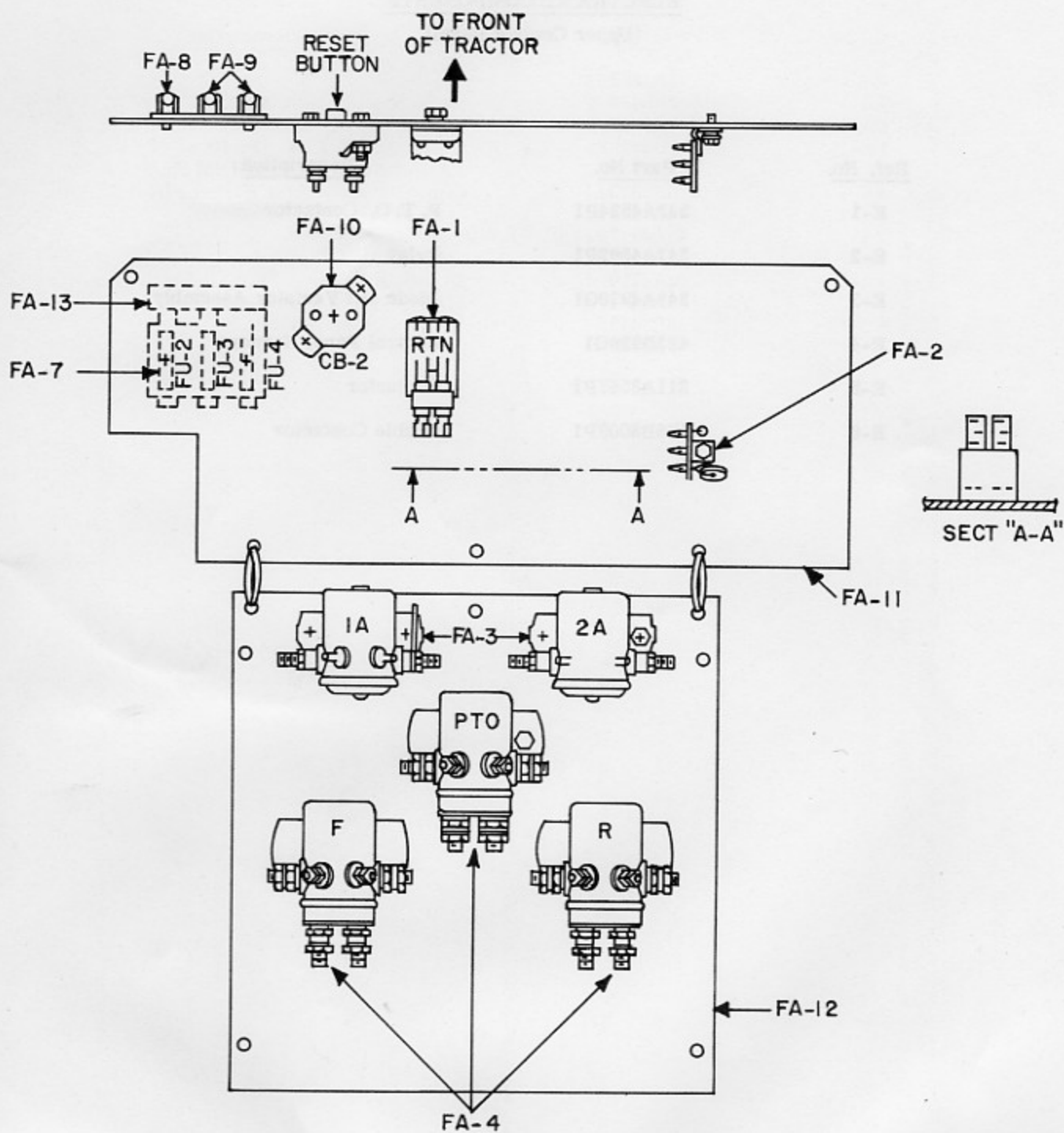

Fig. E14-4

ELECTRICAL COMPONENTS

<u>Ref. No.</u>	<u>Part No.</u>	<u>Description</u>
FA-1	243A4562P1	Relay
FA-2	178B8457G2	Diode and Varistor Asm.
FA-3	247A7462P1	Contactor (1A, 2A)
FA-4	178B8385P1	Contactor (P. T. O., F, R)
FA-5	127D8112G1	Control Panel Harness (Not Shown)
FA-6	178B8310G1	Control Panel Adder Harness (Not Shown)
FA-7	244A7463P1	Fuse Block
FA-8	243A4597P1	Fuse 30
FA-9	243A4657P1	Fuse 20
FA-10	243A4719P1	Circuit Breaker
FA-11	178B8444P1	Upper Control Panel
FA-12	178B8445P1	Lower Control Panel
FA-13	211A3528P1	Fuse Decal

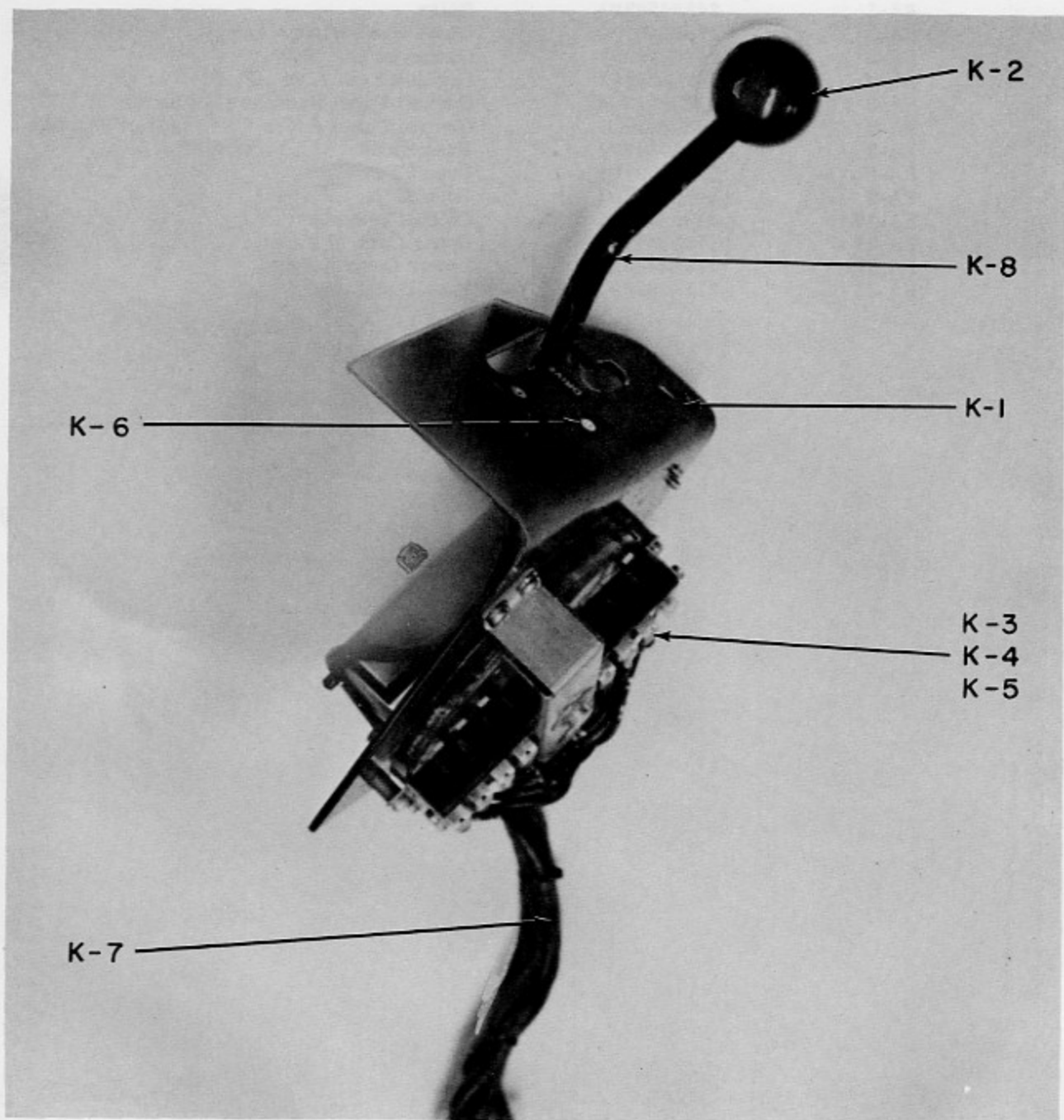

Fig. E14-5

SPEED CONTROL

<u>Ref. No.</u>	<u>Part No.</u>	<u>Description</u>
K-1*	423D259G1	Speed Control (E14RC)
K-1*	423D297G1	Speed Control (E14RD, RH)
K-1*	423D297G3	Speed Control (E14AA, RJ)
K-2	211A3249P1	Speed Control Knob
K-3	211A3198P1	Start Switch, 3 Tabs, N. O., N. C. and Common
K-4	211A3198P2	1A, 2A Switch, 2 Tabs, N. O. and Common (Also Rev. Sw. in E14RC)
K-6	211A3558P2	Reverse Switch (E14AA, RD, RH, RJ)
K-7*	541C985G1	Throttle Harness (E14RC)
K-7*	155C8065G1	Throttle Harness (E14RD, RH)
K-7*	158C9044G1	Throttle Harness (E14AA, RJ)
K-8	211A3239G1	Lever

\*It is imperative when ordering a speed control or parts, that you specify the model number of the tractor and serial number of the tractor to insure receiving the proper part.

NOTE: Roll Pin connecting throttle lever to cam shaft must be replaced by clevis pin, Part No. 247A7830P1, and cotter pin, Part No. N503P312 1/32 x 3/4 LG. to improve throttle assembly.

ER8-36

## TABLE OF CONTENTS

<u>FIGURE</u>	<u>TITLE</u>
ER8-1	Body Assembly, Side View
ER8-2	Body Assembly, Top View
ER8-3	Brake Pedal Detail
ER8-4	Clutch Rod Clip Detail
ER8-5	Shift Bracket Detail
ER8-6	Chassis Assembly, Side View
ER8-7	Steering Assembly Detail
ER8-8	Mower Lift Pivot Detail
ER8-9	Lift Bar Detail
ER8-10	Fuse Block
ER8-11	Chassis Assembly, Top View
ER8-12	Belt Drive Detail
ER8-13	Motor and Plate Detail
ER8-14	Motor Plate Pivot Detail
ER8-15	Brake Rod Chain Detail
ER8-16	Control Panel Assembly

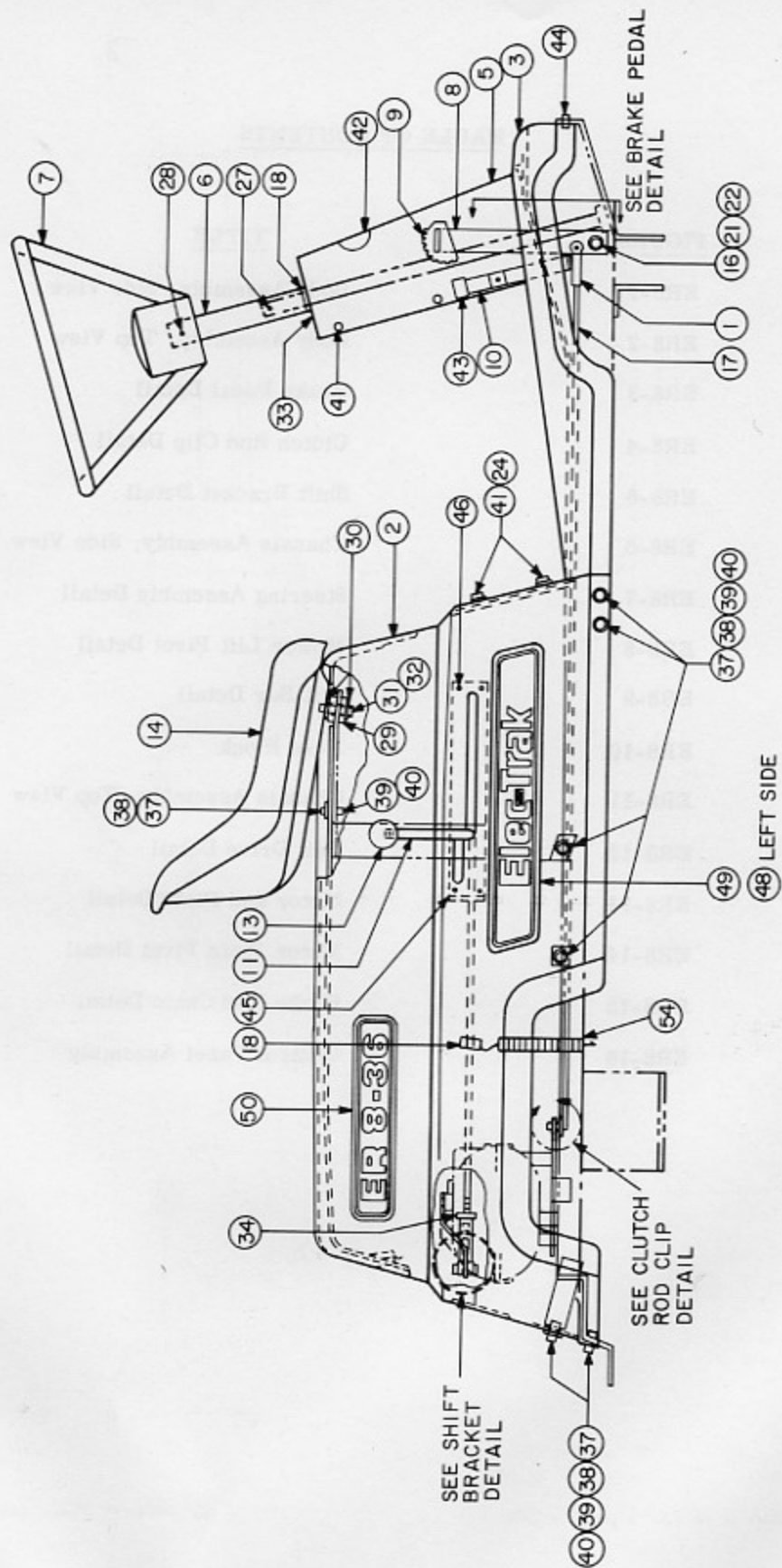

Fig. ER8-1

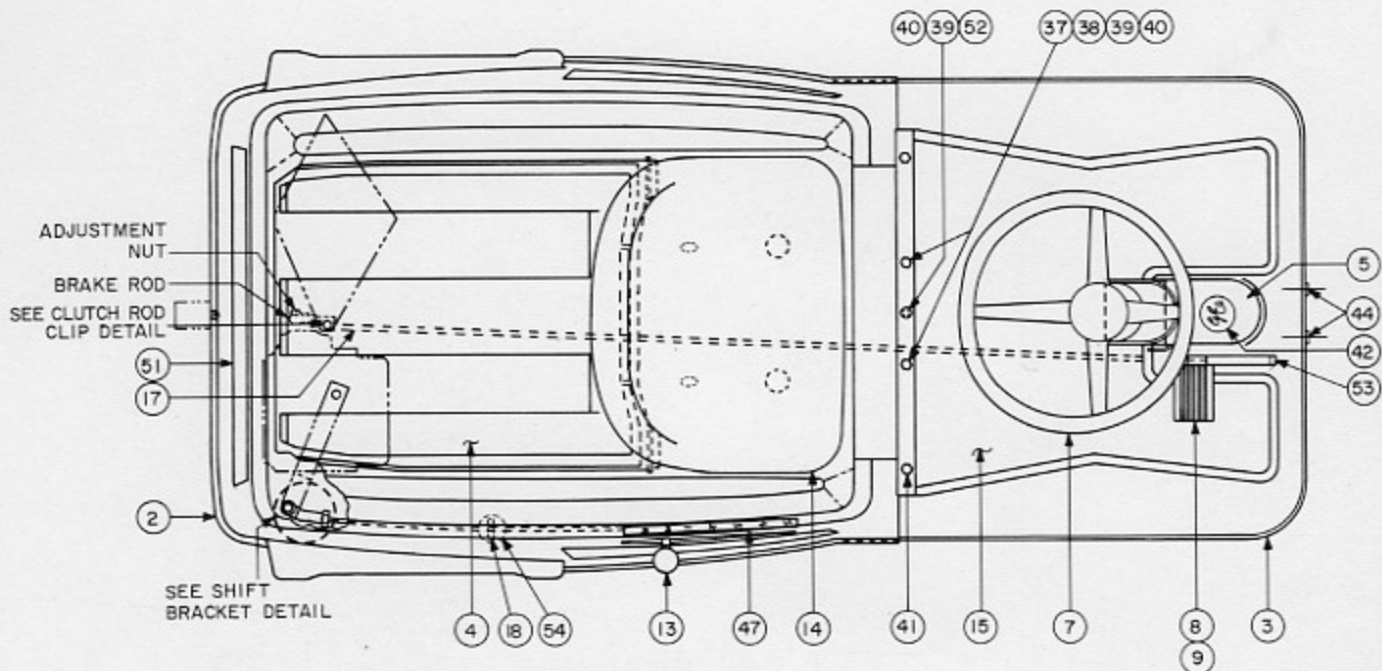

Fig. ER8-2 Body Assembly, Top View

MOTOR PLATE

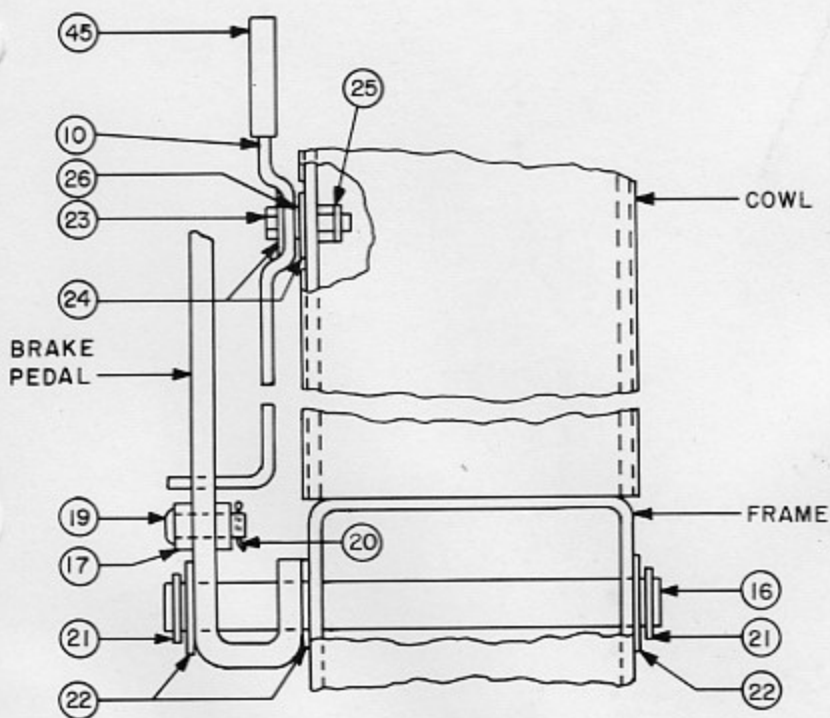

Fig. ER8-3 Brake Pedal Detail

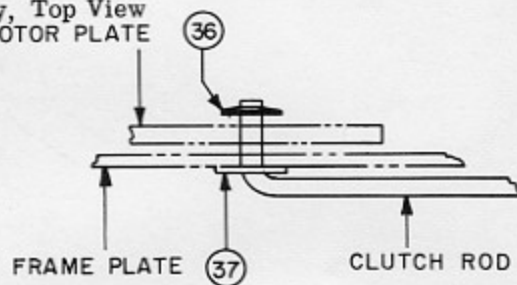

Fig. ER8-4 Clutch Rod Clip Detail

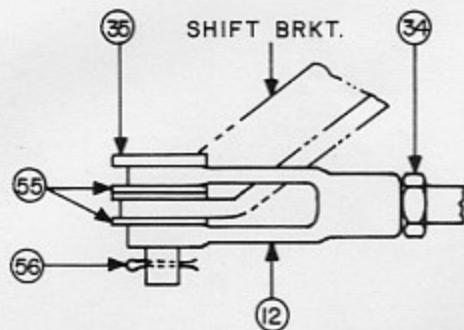

Fig. ER8-5 Shift Bracket Detail



BODY ASSEMBLY

<u>Ref. No.</u>	<u>Part No.</u>	<u>Description</u>
1	244A7168P1	Clutch Rod Clevis
2	127D8182G1	Body Housing with Decals and Shift Gate
3	127D8163P1	Foot Pan
4	247A7765G1	Cover and Latch Asm.
	247A7458P3	Pop Rivet (0.125 x 0.337 L)
	247A7752P1	Latch
5	191B4569P1	Cowl
6	247A7660P1	Steering Shaft Extension
7	127D8176P1	Steering Wheel
8	191B4575P1	Brake Pedal
9	247A7767P1	Brake Pedal Pad
10	247A7729P1	Parking Brake Lever
11	191B4587P1	Shift Rod
12	247A7740P1	Shift Rod Clevis
13	211A3249P1	Shift Knob
14	158C9099P1	Seat (With bumpers)
	243A4639P1	Seat Bumper (Some ER8AA Only)
15	191B4581P1	Floor Mat
16	247A7775P1	Brake Pedal Pin
17	244A7126P4	Clutch Rod
18	244A7322P1	Washer
19	211A3505P14	Clevis Pin
20	N503P912B6	Cotter Pin (3/32 x 3/4)
21	N922P50B6	Retaining Ring 1/2 dia.
22	N402AP15B6	Washer 1/2 dia.
23	N68P16012B6	Machine Screw #10-32 x 3/4
24	N402AP39B6	Washer #10
25	N264P16B6	Lock Nut #10-32
26	211A3584P1	Curved Washer #10
27	N533P2516	Spring Dowel Pin 1/4 x 1
28	N533P2536	Spring Dowel Pin 1/4 x 2 1/4
29	243A4550P32	Spacer
30	N402AP72B6	Washer 5/16
31	N22P23030B6	Hex Head Bolt 5/16-18 x 1 7/8 (ER8AA)
	247A7816P1	Stud (ER8BA)
	N210P23B6	Hex Nut, 5/16-18 (ER8BA)
32	N405P12B6	Lockwasher 5/16
33	247A7777P1	Decal-Parking Brake
34	N213P24B6	Jam Nut 3/8-24
35	211A3505P15	Clevis Pin
36	211A3488P1	Spring Clip 1/4
37	N402AP41B6	Washer 1/4
38	N22P21012B6	Hex Head Bolt 1/4-20 x 3/4
39	N405P11C6	Lockwasher 1/4
40	N210P21B6	Hex Nut 1/4-20
41	N722AP16008C6	Thread Rolling Screw #10-32 x 1/2
42	244A7394P1	Decal - GE
43	244A7466P3	Hand Grip - Parking Brake
44	N722AP21008C6	Thread Rolling Screw 1/4-20 x 1/2
45	191B4568P1	Shift Gate
46	247A7458P4	Rivet
47	191B4594P1	Decal - Shift
48	158C9093P1	Decal - Electrak (left side)
49	158C9093P2	Decal - Electrak (right side)
50	191B4582P1	Decal - ER8-36
51	158C9090P1	Decal - General Electric
52	N22P21010B6	Hex Head Bolt 1/4-20 x 5/8
53	247A7428P3	Trim
54	211A3489P1	Spring
55	247A7656P1	Plastic Washer
56	N503P1212B6	Cotter Pin, 1/8 x 3/4

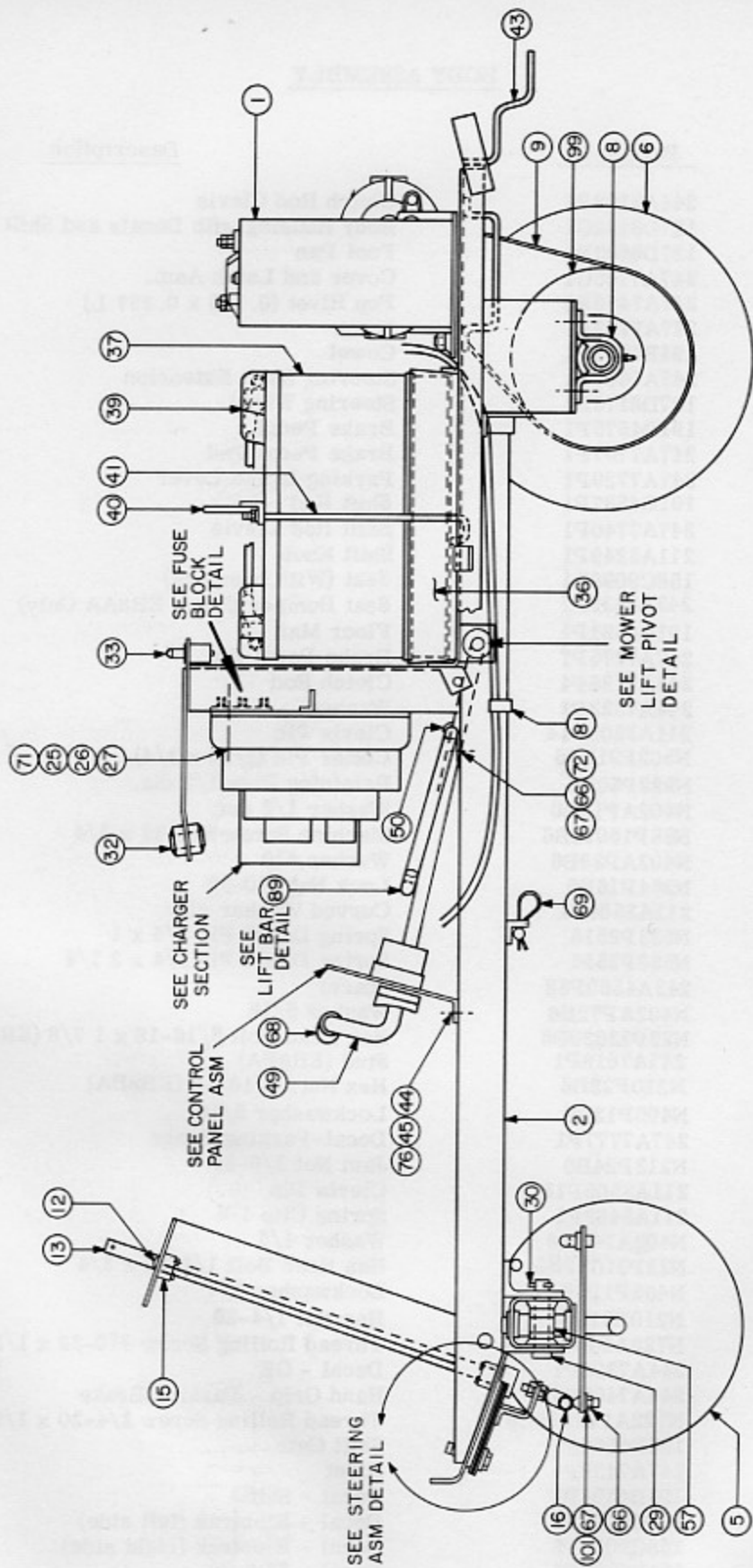

Fig. ER8-6

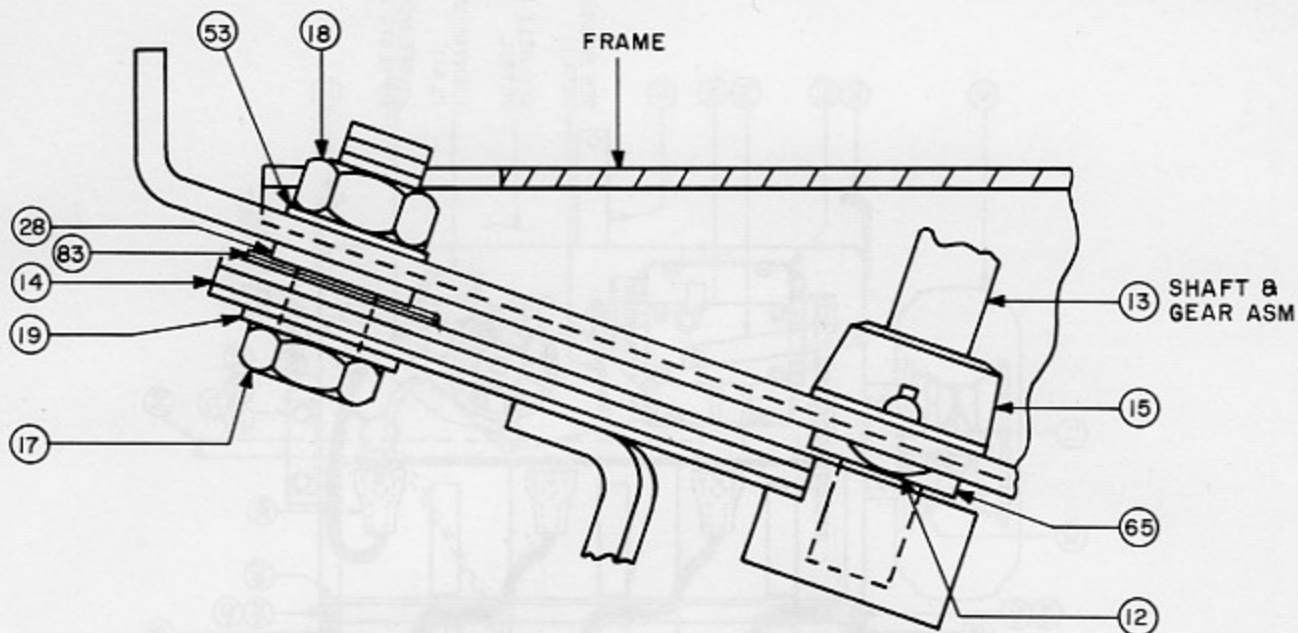

Fig. ER8-7 Steering Assembly Detail

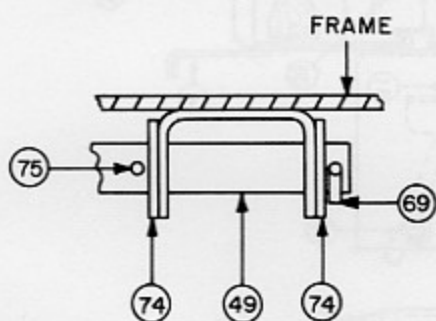

Fig. ER8-8 Mower Lift Pivot Detail

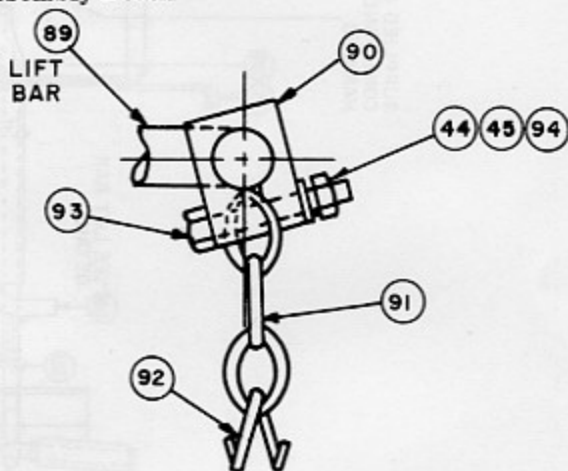

Fig. ER8-9 Lift Bar Detail

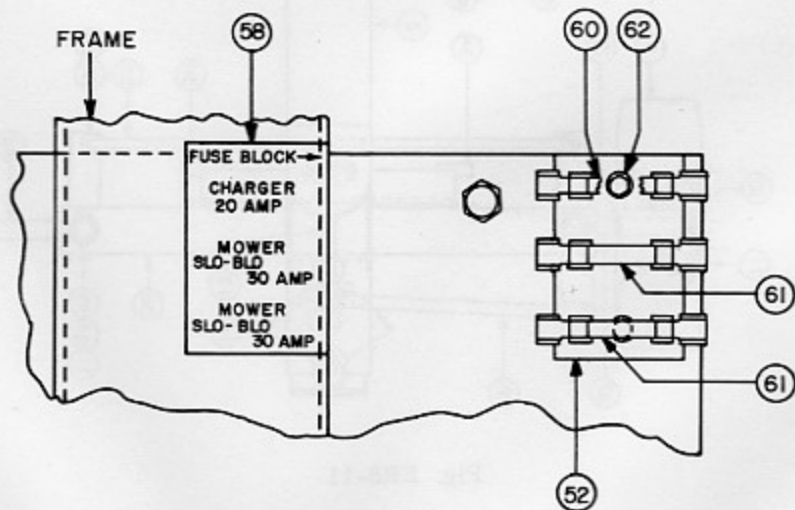

Fig. ER8-10 Fuse Block

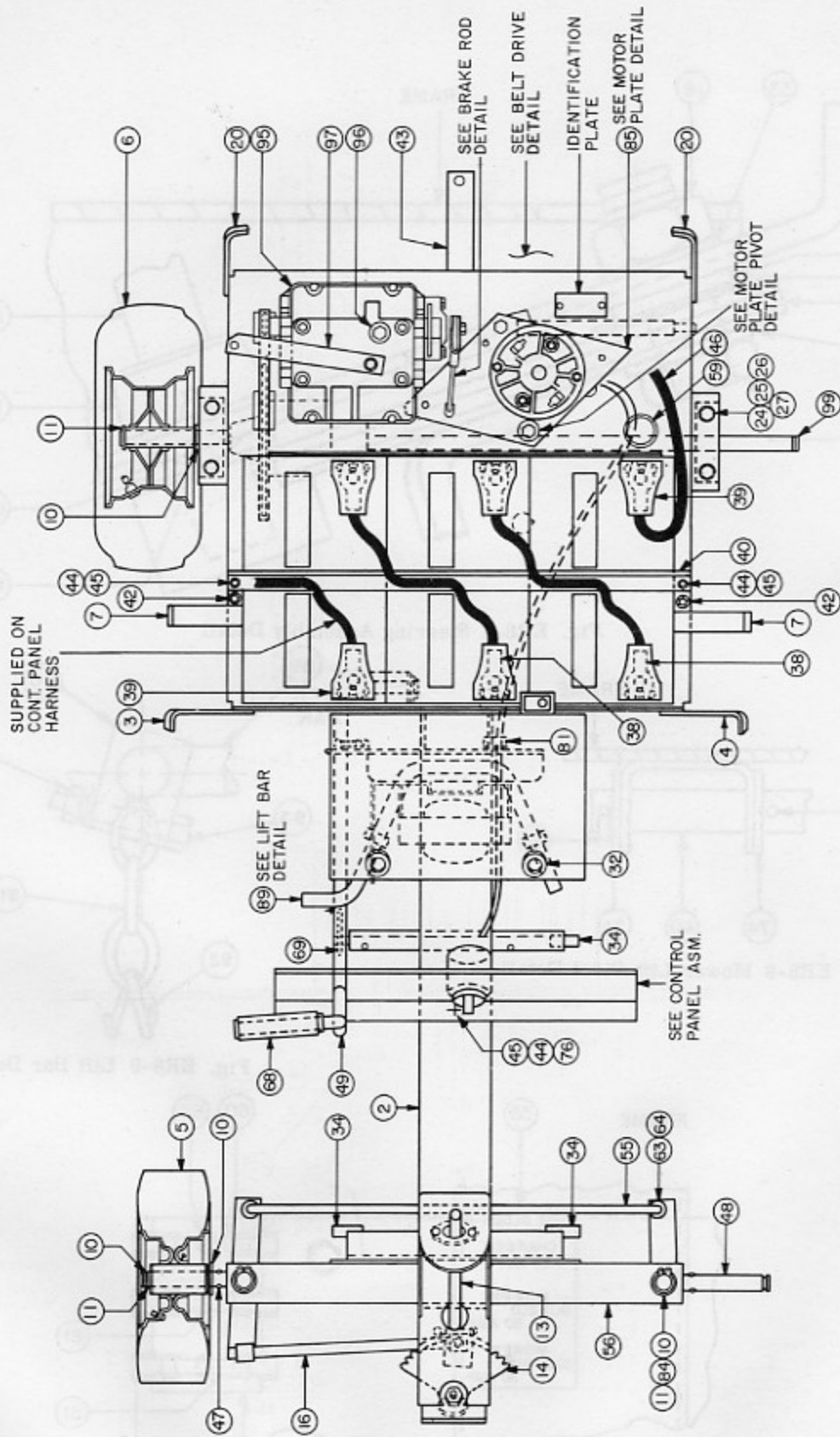

Fig. ER8-11

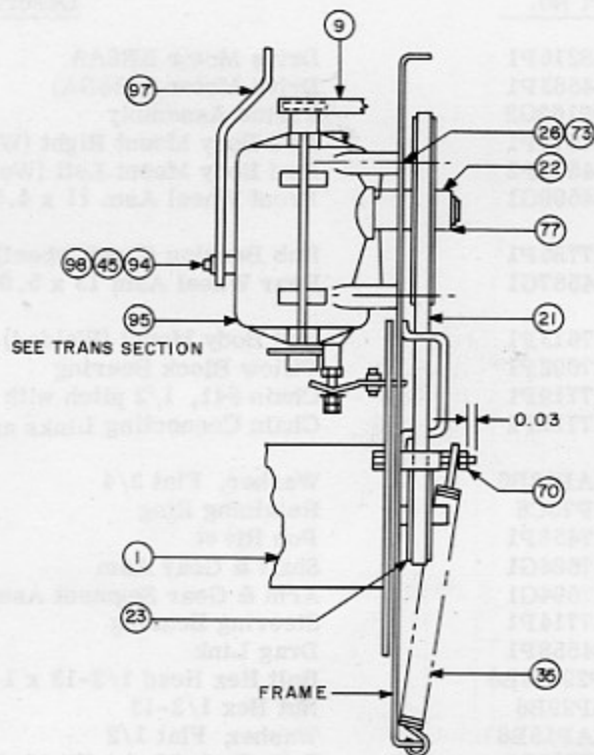

Fig. ER8-12 Belt Drive Detail

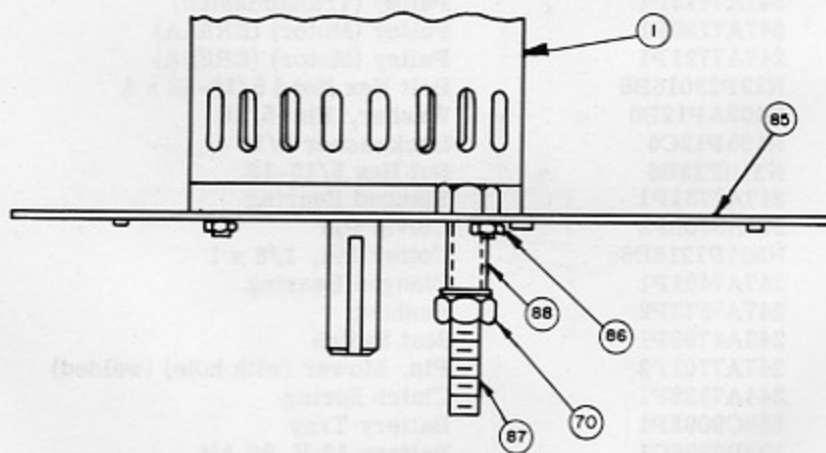

Fig. ER8-13 Motor Plate Detail

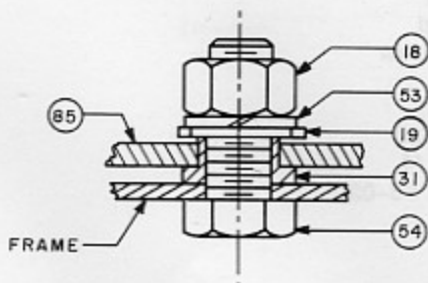

Fig. ER8-14 Motor Plate Pivot Detail

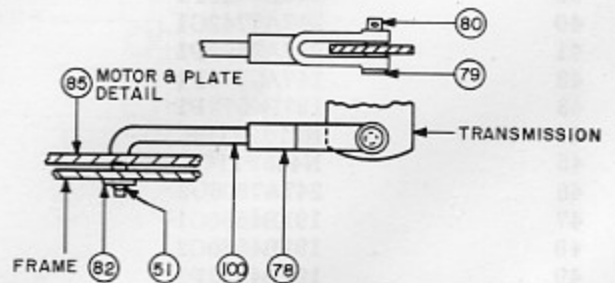

Fig. ER8-15 Brake Rod Detail

CHASSIS ASSEMBLY

<u>Ref. No.</u>	<u>Part No.</u>	<u>Description</u>
1	178B8216P1	Drive Motor ER8AA
	191B4563P1	Drive Motor (ER8BA)
2	127D8162G2	Frame Assembly
3	191B4573P1	Fwd Body Mount Right (Welded)
4	191B4573P2	Fwd Body Mount Left (Welded)
5	191B4599G1	Front Wheel Asm 11 x 4.00-5
	247A7785P1	Hub Bearing (2 per wheel)
6	191B4567G1	Rear Wheel Asm 13 x 5.00-6
7	247A7613P1	Mid Body Mount (Welded)
8	247A7692P1	Pillow Block Bearing
9	247A7719P1	Chain #41, 1/2 pitch with links & clip
	247A7719P2	Chain Connecting Links and Spring Clip
10	N402AP18B6	Washer, Flat 3/4
11	N922P75C6	Retaining Ring
12	247A7458P1	Pop Rivet
13	247A7686G1	Shaft & Gear Asm
14	247A7694G1	Arm & Gear Segment Asm
15	247A7714P1	Steering Bearing
16	191B4558P1	Drag Link
17	N22P29024B6	Bolt Hex Head 1/2-13 x 1 1/2
18	N258P29B6	Nut Hex 1/2-13
19	N402AP15B6	Washer, Flat 1/2
20	247A7717P1	Rear Body Mount (Welded)
21	211A3226P14	Belt (ER8AA)
	211A3226P15	Belt (ER8BA)
22	247A7715P1	Pulley (Transmission)
23	247A7720P1	Pulley (Motor) (ER8AA)
	247A7721P1	Pulley (Motor) (ER8BA)
24	N22P23016B6	Bolt Hex Head 5/16-18 x 1
25	N402AP12B6	Washer, Flat 5/16
26	N405P12C6	Lockwasher 5/16
27	N210P23B6	Nut Hex 5/16-18
28	247A7731P1	Flanged Bearing
29	211A3505P2	Clevis Pin
30	N503P1216B6	Cotter Pin, 1/8 x 1
31	247A7494P1	Flanged Bearing
32	247A7573P2	Bushing
33	243A4790P1	Seat Switch
34	247A7701P2	Pin, Mower (with hole) (welded)
35	244A7328P1	Clutch Spring
36	158C9092P1	Battery Tray
37	178B8236G1	Battery 12 V 90 AH
38	247A7804G1	Battery Cable and Cover Assembly
39	178B8142P1	Battery Cover
40	247A7742G1	Battery Clamp
41	247A7699P1	Battery Holddown
42	247A7773P1	Push Nut
43	191B4572P1	Hitch (Welded)
44	N210P21B6	Nut, Hex 1/4-20
45	N405P11C6	Lockwasher 1/4
46	247A7806G2	Battery Cable #8-03
47	191B4560G1	Spindle Right
48	191B4560G2	Spindle Left
49	191B4593P1	Lift Rod
50	247A7754P1	Mower Lift Clamp
51	211A3488P1	Push Nut

## CHASSIS ASSEMBLY (Cont'd)

<u>Ref. No.</u>	<u>Part No.</u>	<u>Description</u>
52	244A7463P1	Fuse Block
53	N405P15C6	Lockwasher 1/2
54	N22P29020B6	Bolt Hex Head 1/2-13 x 1 1/4
55	191B4561P1	Tie Rod
56	191B4562G1	Front Axle
57	247A7689P1	Sleeve Bearing
58	247A7771P1	Fuse Decal (ER8AA)
	247A7818P1	Fuse Decal (ER8BA)
59	247A7772P1	Snap Bushing
60	243A4657P1	Fuse 20A
61	243A4597P1	Fuse 30A Slow Blow (ER8AA)
	247A7817P1	Fuse, 40 amp Slow Blow (ER8BA)
62	N722AP13008C	Screw Self Tapping 6-32 x 1/2
63	247A7697P1	Flanged Bearing
64	243A4554P1	Push Nut
65	244A7322P1	Washer
66	N210P25B6	Nut, Hex 3/8-16
67	N405P13C6	Lockwasher 3/8
68	247A7760P1	Handle Grip
69	211A3256P1	Spring Cotter Pin
70	N264P25C6	Lock Nut 3/8-16
71	N22P23030B6	Bolt Hex Head 5/16-18 x 1 7/8
72	N22P25012B6	Bolt Hex Head 3/8-16 x 3/4
73	N22P23010B6	Bolt Hex Head 5/16-18 x 5/8
74	N402AP17B6	Washer, Flat 5/8
75	N503P1012B6	Cotter Pin, 7/64 x 3/4
76	N22P21010B6	Bolt Hex Head 1/4-20 x 5/8
77	247A7776P1	Retaining Ring
78	244A7168P1	Clevis
79	211A3505P13	Clevis Pin
80	N503P912B6	Cotter Pin 3/32 x 3/4
81	244A7163P1	Cable Clip
82	N402AP11B6	Washer, Flat 1/4
83	243A4642P4	Shim Washer, 1/16 x 0.010
84	211A3236P1	Bearing (2 per spindle)
85	541C653P1	Plate, Motor
86	N264P23B6	Lock Nut 5/16-18
87	N25P25044B6	Bolt Hex Head 3/8-16 x 2 3/4
88	243A4550P33	Spacer
89	191B4592P1	Lift Bar
90	247A7759P1	Clamp
91	244A7153P1	Chain, Lift
92	243A4845P2	Lap Link
93	N22P21024B6	Bolt, Hex Head 1/4-20 x 1 1/2
94	243A4613P1	Shim Washer, 3/4 x 0.008
95	158C9089P1	Transmission & Brake Asm
96	191B4601P1	Neutral Switch
97	191B4586P1	Shift Bracket
98	N22P20012B6	Bolt Hex Head 1/4-28 x 3/4
99	158C9088G1	Differential & Sprocket Asm
100	244A7126P3	Brake Rod
101	N402AP13B6	Washer, Flat 3/8
102	247A7719G1	Roller Chain Assembly
103	247A7719G2	Connecting Link Set

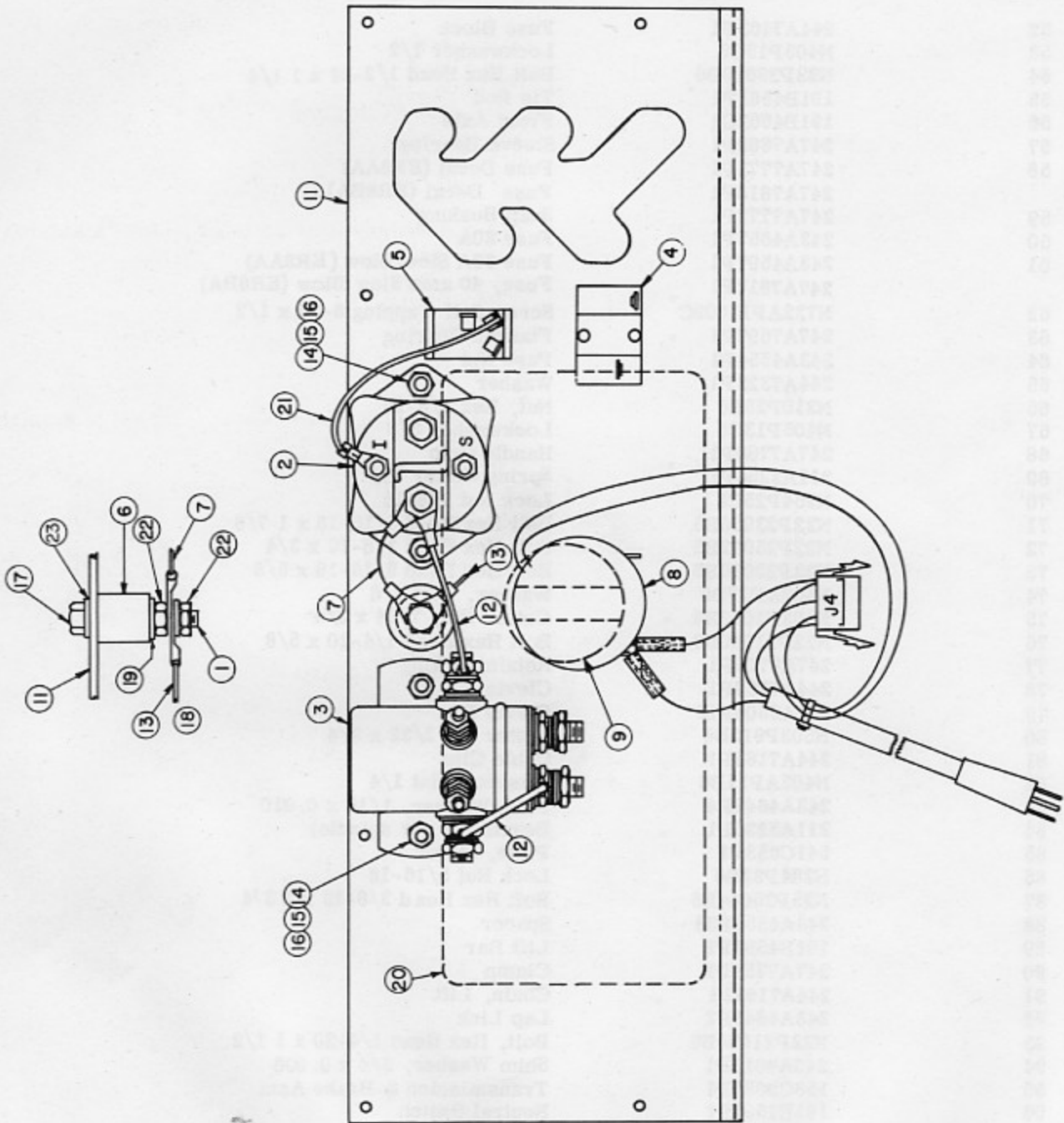

Fig. ER8-16

CONTROL PANEL ASSEMBLY

<u>Ref. No.</u>	<u>Part No.</u>	<u>Description</u>
1	N90P21018	Stud 1/4-20 x 1 1/8
2	244A7063P1	Line Contactor
3	178B8385P1	PTO Contactor
4	247A7778G1	Key Switch (With Keys)
	247A7780P1	Keys (2 Only)
5	244A7229P1	PTO Switch
6	211A3165P1	Insulator
7	211A3448G2	Fusible Link
8	178B8238G3	Timer Assembly (May Be Used On E8M Standard Tractors)
	211A3507P1	Timer (Only)
	211A3555G1	Cord Asm (Only)
9	243A4549P1	Timer Knob
10	244A7386P1	Timer Decal
11	127D8174P1	Control Panel
12	244A7334G15	Jumper Wire
13	127D8185G1	Control Panel/Tractor Harness with Diode Assembly
	247A7784G1	Diode Asm
14	N68P16008	Screw #10-32 x 1/2, Black
15	N405P9C6	Lockwasher #10
16	N210P16B6	Hex Nut #10-32
17	N22P21008	Bolt 1/4-20 x 1/2, Black
18	N405P11C6	Lockwasher 1/4
19	N402AP41B6	Flat Washer 1/4
20	155C8044P1	Control Panel Decal
21	178B8294G19	Jumper Wire
22	N210P21B6	Hex Nut 1/4-20
23	N405P11	Lockwasher, #10, Black



TABLE OF CONTENTS

<u>FIGURE</u>	<u>TITLE</u>
I5-1	Body Components
I5-2	Dash Components (26CE20AA and BA)
I5-3	Dash Components (26CE20CA and Later)
I5-4	Electrical Components (26CE20AA and BA)
I5-5	Electrical Components (26CE20CA and Later)
I5-6	Speed Controls

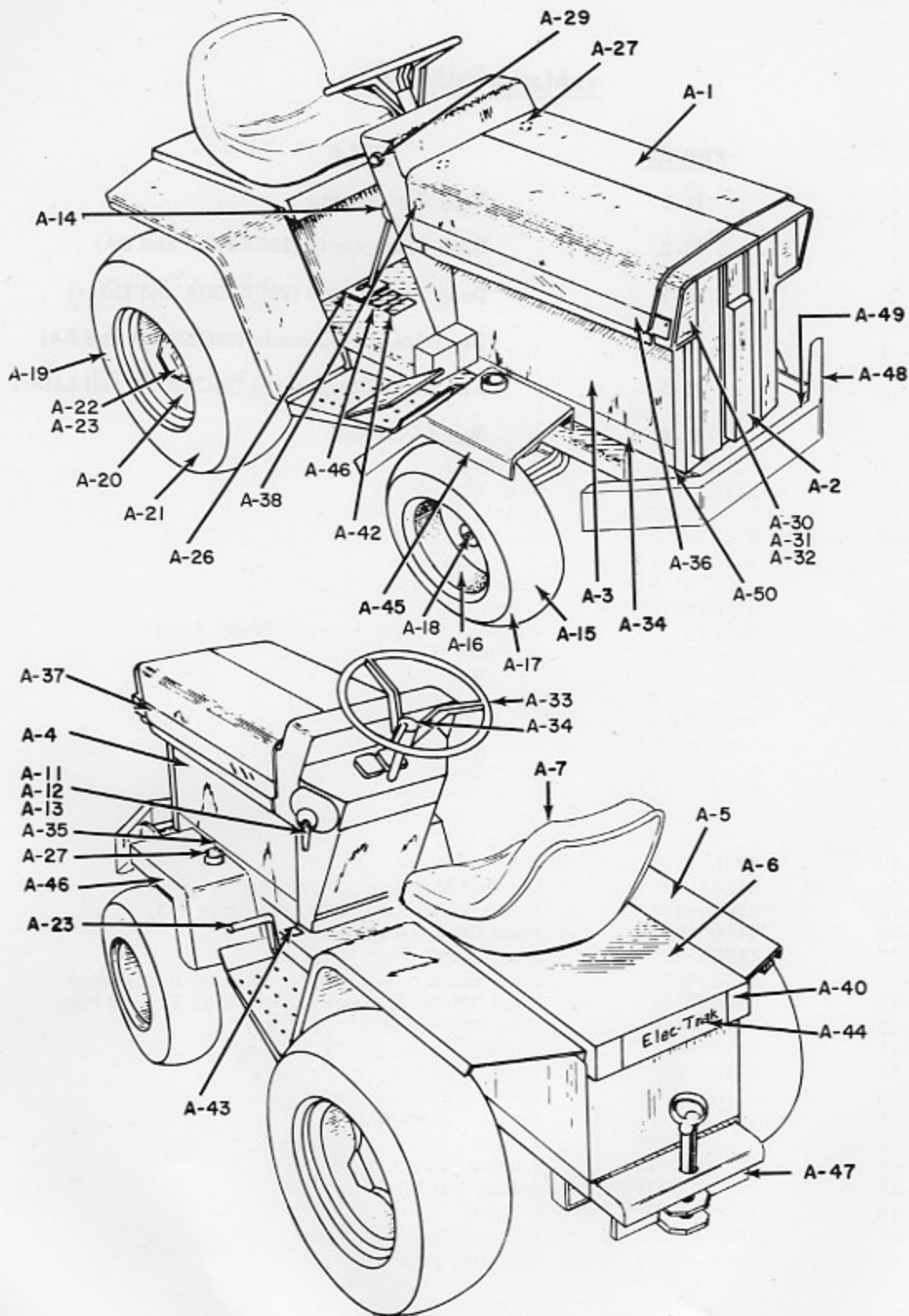

Fig. 15-1

## BODY COMPONENTS

<u>Ref. No.</u>	<u>Part No.</u>	<u>Description</u>
A-1	155C8031G1	Hood Assembly
A-2	422D214P2	Front Grill
A-3	422D837P2	Side Body Panel, Right
A-4	422D838P2	Side Body Panel, Left
A-5	423D221G4	Rear Battery Box Assy. (Includes Fenders)
A-6	541C38G3	Rear Battery Box Cover (Less Seat, Stiffener, Decals)
A-7	247A7412G1	Seat Assembly - 1 Piece
A-11	178B8137G1	Power Disconnect
A-12	211A3448G1	Fusible Link (Located on Power Disconnect)
A-13	244A7089P1	Hand Grip for Power Disconnect
A-14	211A3249P3	Gear Shift Knob
A-15	155C8034G2	Front Wheel-Tire
A-16	158C9070P1	Wheel-Front
A-17	244A7033P2	Tire-Front
A-18	243A4640P1	Bearing, Front Wheel
A-19	244A7032G1	Rear Wheel-Tire
A-20	155C8052P1	Wheel-Rear
A-21	244A7031P1	Tire-Rear
A-22	243A4589P1	Wheel Lug
A-23	244A7030P1	Washer, Dished (Used on Wheel Lugs)
A-24	243A4789P1	Stiffener (For Cover)
A-25	243A4526P1	"T" -Nut (For Stiffener)
A-26	243A4797P1	Decal, "D2, D1, L, LL)
A-27	244A7287A1	Tube and Support (For Overhead Guard)
A-28	178B8226P1	Wire Cover (Under Carriage)
A-29	243A4881P1	Horn Button
A-30	211A3413P1	Headlight Lens
A-31	163B9936G1	Reflector and Light Assembly
A-32	211A3592P1	Lamp (GE 1076)
A-33	423D255P1	Steering Wheel
A-34	243A4828G1	Cap and Monogram Assembly
A-35	422D848P14	Brake Pedal Assembly (See Page 5-3)
A-36	422D848P13	Hood Decal, Right Hand
A-37	422D848P1	Hood Decal, Left Hand
A-38	243A4639P1	Hood Rubber Bumper (Mounted on Both Sides)
A-39	243A4639P2	Hood Rubber Bumper (Mounted on Top - 2 Req.)
A-40	243A4870P1	Rear Tail Reflector (2 Req.)
A-41	243A4869P1	Decal, "To Facilitate Shifting"
A-42	243A4794P1	Decal, "Shift to Lower Gear"
A-43	211A3247P1	Decal, "Parking Brake"
A-44	178B8024P1	Decal, "Elec-Trak"
A-45	155C8108P1	Fender, Front (Right)
A-46	155C8108P2	Fender, Front (Left)
A-47	178B8088G1	Spring Pin Hitch
A-48	155C8027P1	Bumper
A-49	178B8089P1	Bumper Support
A-50	243A4999P1	Mounting Bracket

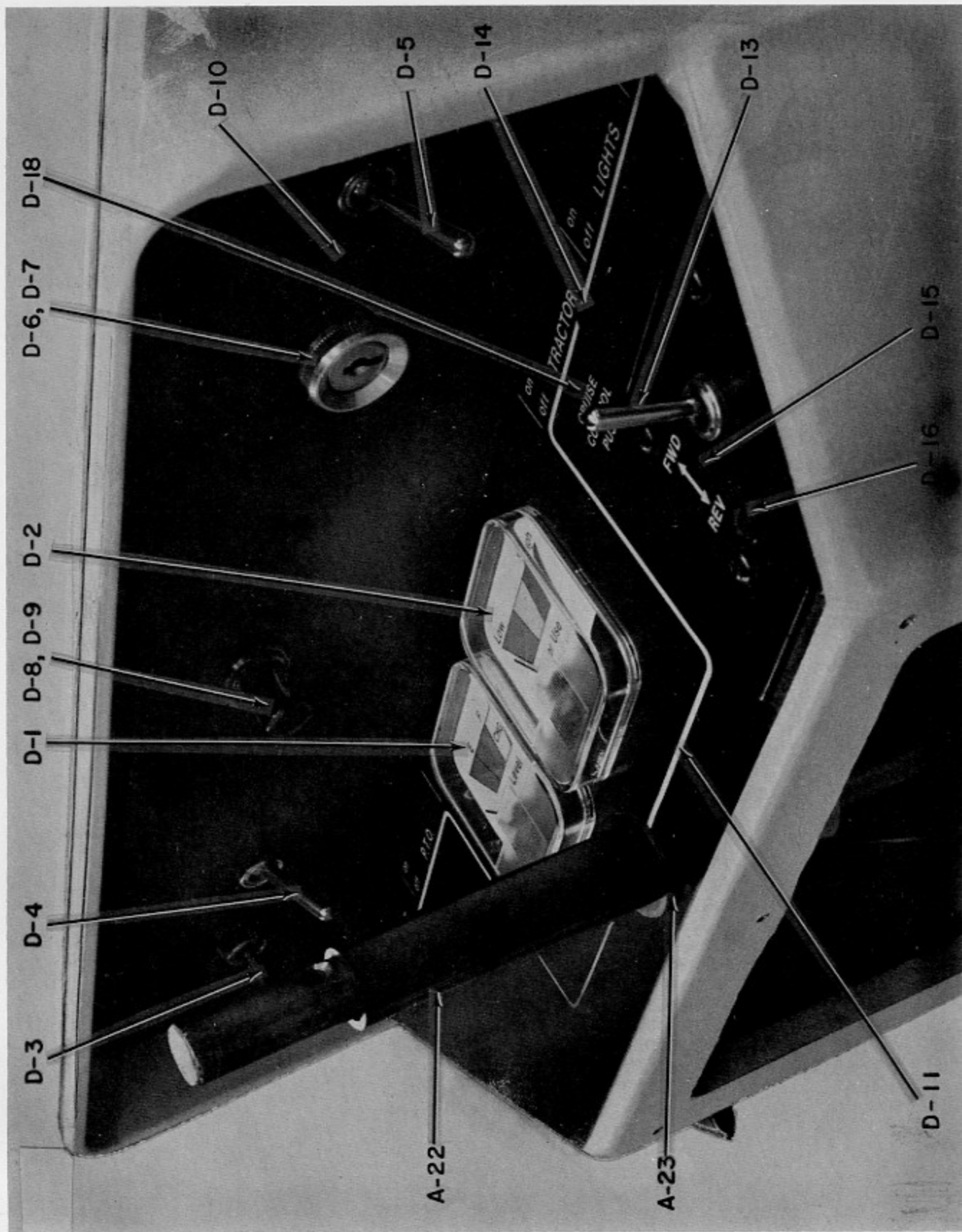

Fig. 15-2

DASH COMPONENTS

Models 26CE20AA - 26CE20BA

<u>Ref. No.</u>	<u>Part No.</u>	<u>Description</u>
D-1	243A4629G1	Fuel Level Gauge
D-2	243A4630G4	Power Use Gauge
D-3	243A4531P2	Lift Switch
D-4	243A4531P1	P. T. O. Switch
D-5	243A4531P3	Light Switch
D-6	243A4573P1	Key Switch
D-7	211A3597P1	Key
D-8	243A4574P1	Light, Dash
D-9	211A3591P1	Lamp (GE 1815)
D-10	163B9821P1	Dash Panel
D-11	541C681P1	Decal, Dash
D-12	541C994G1	Dash Harness
D-13	243A4814P1	F-R Switch
D-14	243A4848P1	Cruise Control Switch
D-15	243A4815P2	Decal (F-R)
D-16	243A4979P1	Reverse Light
D-17	178B8095G1	Cruise Control Harness (Not Pictured)
D-18	243A4815P1	Decal (Cruise Control)
D-19	211A3551P1	Tubing (Not Pictured - Insulation for Switch Terminals)
D-20	127D8106P1	Dash Panel (Requires REF D-21)
D-21	247A7469P1	Plug, Switch
D-22	243A4809P1	Sleeve (AA, BA only)
D-23	243A4576P3	Washer (AA, BA only)

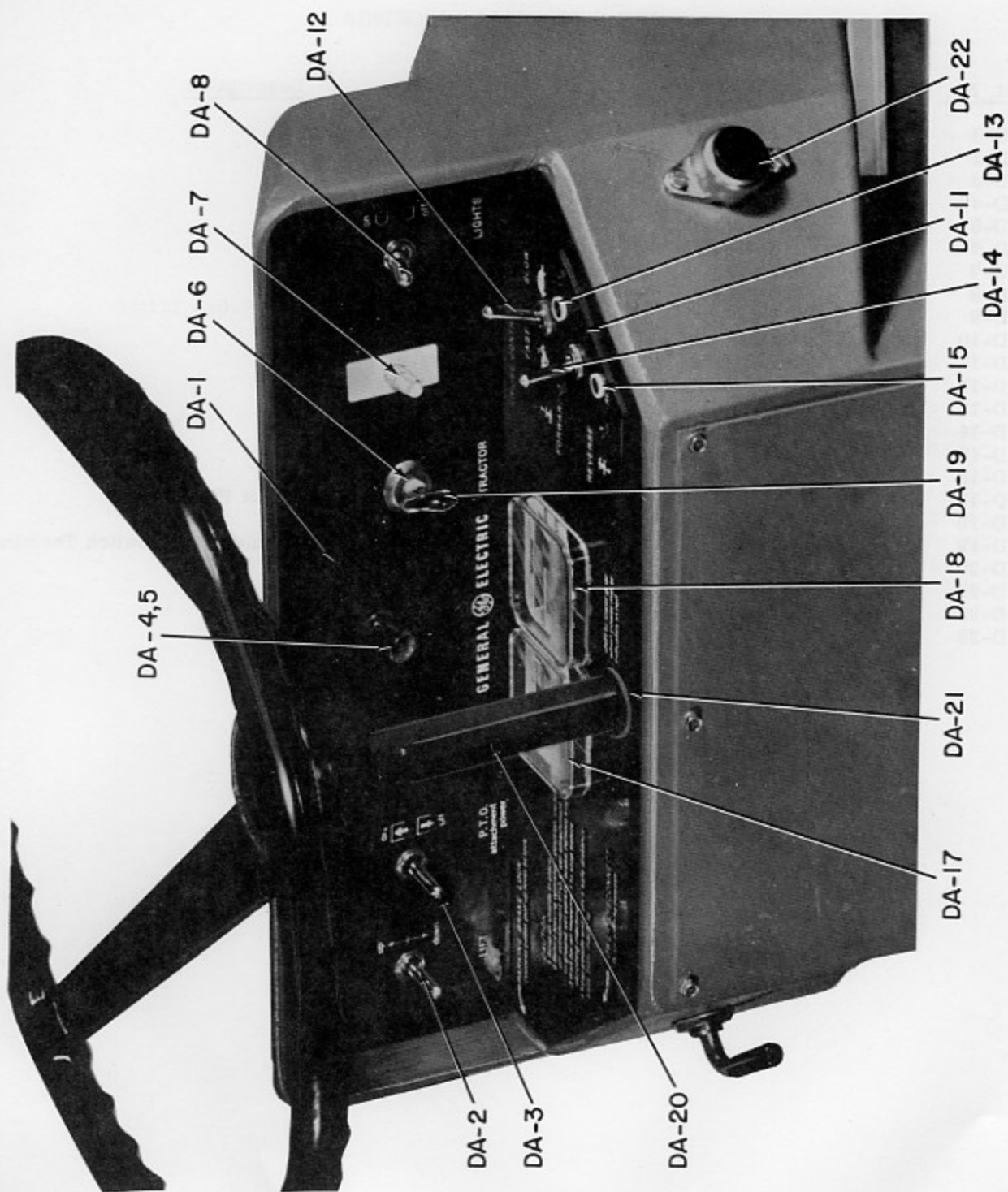

Fig. 15-3

### DASH COMPONENTS

Model 26CE20CA and Later

<u>Ref. No.</u>	<u>Part No.</u>	<u>Description</u>
DA-1	127D8106P1	Dash Panel
DA-2	243A4531P2	Lift Switch
DA-3	244A7229P1	P. T. O. Switch
DA-4	243A4574P1	Light, Dash
DA-5	211A3591P1	Lamp (GE 1815)
DA-6	244A7308P1	Key Switch
DA-7	247A7455P1	Cruise Control Button (Switch)
DA-8	243A4531P3	Light Switch
DA-9	158C9052G1	Dash Harness
DA-10	211A3551P1	Tubing (Not Pictured-Insulation for Switch Terminals)
DA-11	178B8468P1	Plate, Fwd. - Rev.
DA-12	243A4531P3	Cruise Control Switch
DA-13	247A7474P2	Cruise Control Light
DA-14	243A4814P1	Fwd./Rev. Switch
DA-15	247A7474P1	Reverse Light
DA-16	178B8472G1	F-R Control Harness
DA-17	243A4629G1	Fuel Level Gage
DA-18	243A4630G4	Power Use Gage
DA-19	247A7354P1	Key
DA-20	243A4809P2	Sleeve
DA-21	243A4576P3	Washer
DA-22	243A4881P1	Horn Button

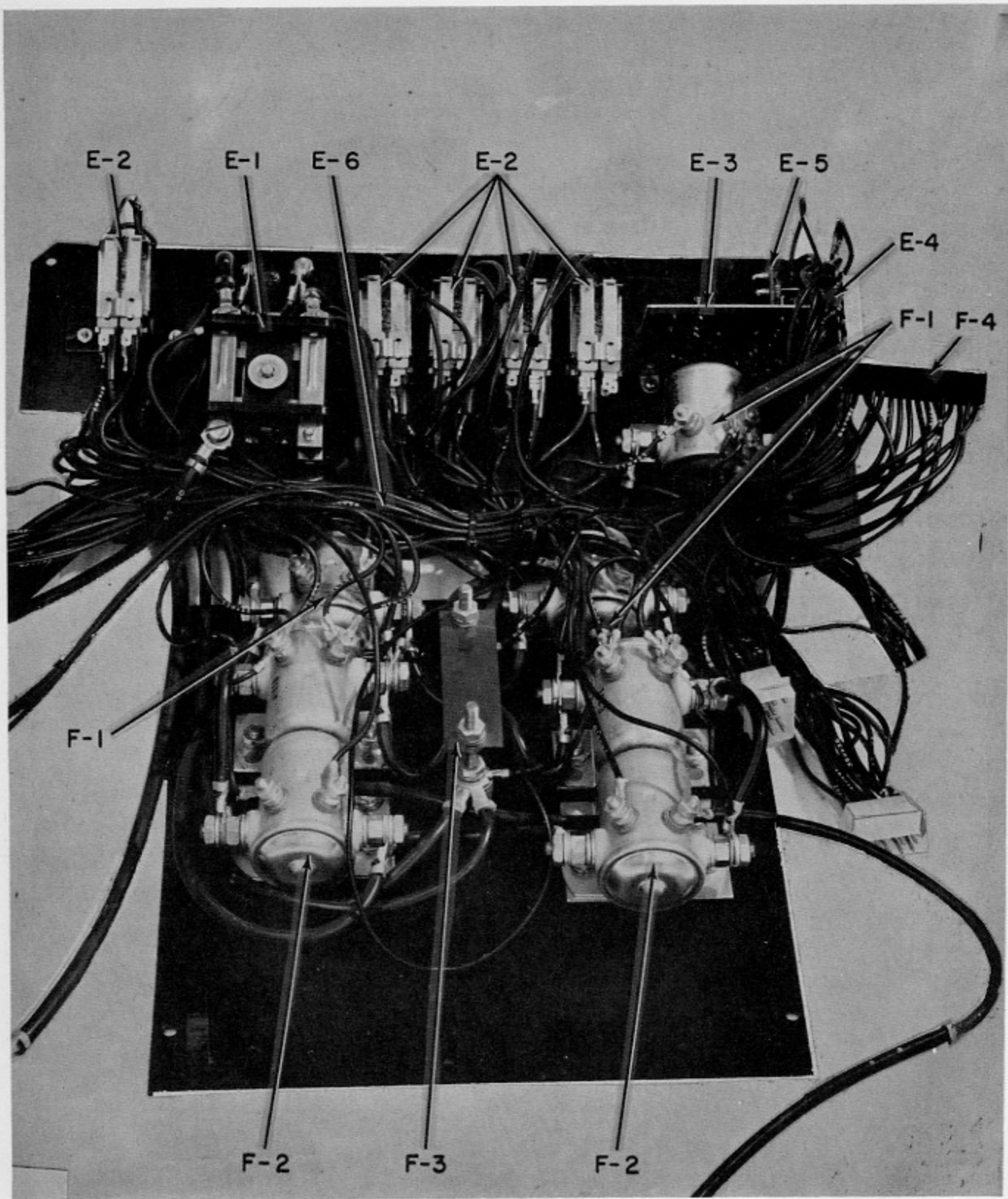

Fig. 15-4

ELECTRICAL COMPONENTS  
Models 26CE20AA and 26CE20BA  
(Upper Control Panel)

<u>Ref. No.</u>	<u>Part No.</u>	<u>Description</u>
E-1	243A4524P1	P. T. O. Contactor
E-2	243A4562P1	Relay
E-3*	178B8107G1	Card #4 (CE20BA)
E-4*	163B9977G1	Card #4 (CE20AA)
E-4	211A3162G2	Card #3
E-5	243A4940G1	Diode and Resistor Assembly (CE20AA Only)
E-6§	127D8006G1	Control Panel Harness (CE20AA)
E-6§	127D8008G1	Control Panel Harness (CE20BA)

(Lower Control Panel)

F-1	211A3567P1	Contactor
F-2	178B8009P1	Double Contactor
F-3	211A3213P3	Current Sensing Shunt
F-4	178B8013P3	Edge Connector

§ It is imperative that when ordering this part you specify the model number and serial number of the tractor to insure your receiving the proper part.

\* To facilitate manufacturing, the diode and resistor assembly was incorporated in the card #4 which caused other electrical changes. Therefore, when ordering this part it is imperative you include the model number and serial number to insure your receiving the proper part.

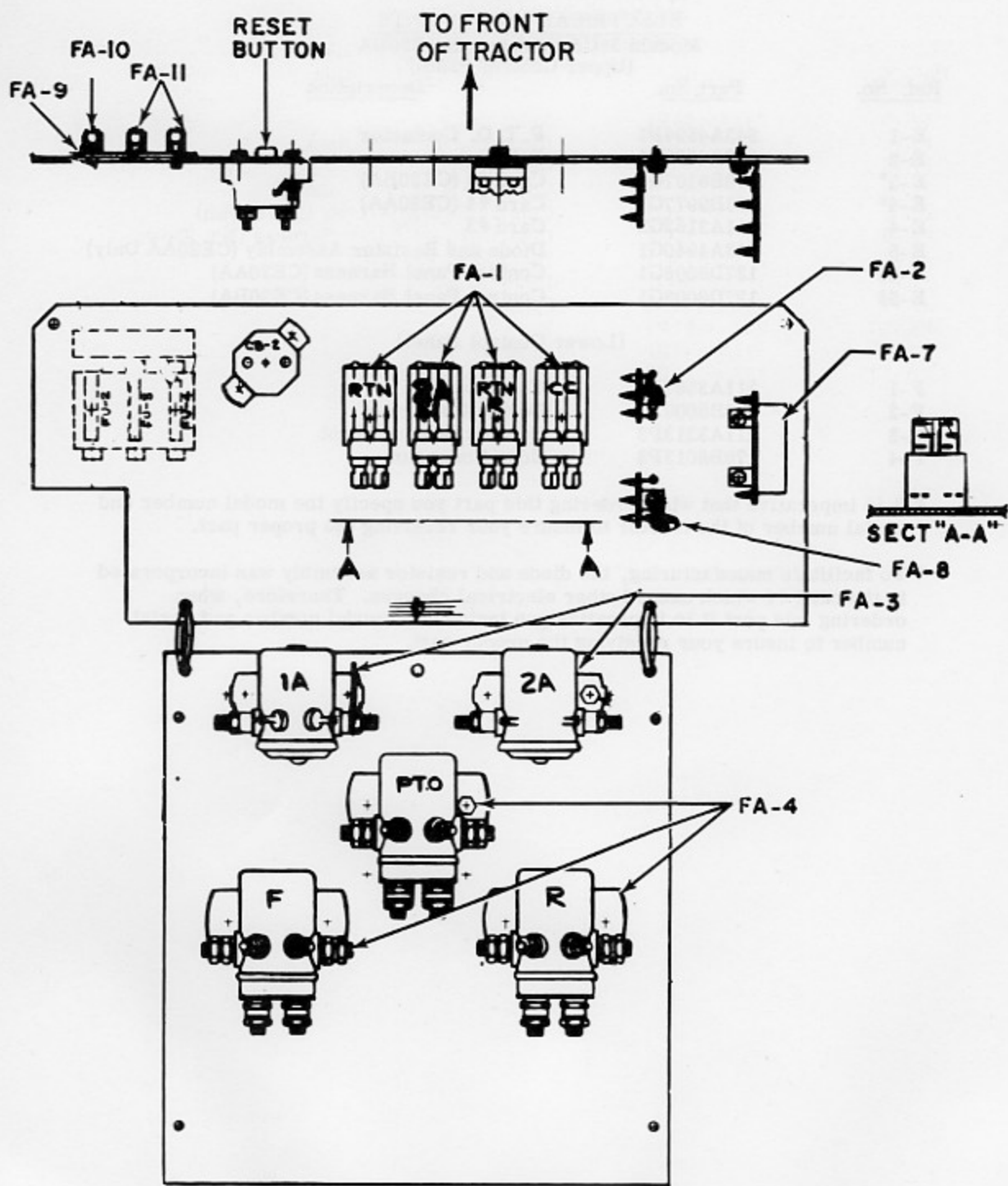

Fig. 15-5

ELECTRICAL COMPONENTS

Model 26CE20CA and Later

<u>Ref. No.</u>	<u>Part No.</u>	<u>Description</u>
FA-1	243A4562P1	Relay
FA-2	178B8457G1	Diode and Varistor Asm.
FA-3	211A3567P1	Contactor (1A, 2A)
FA-4	178B8385P1	Contactor (PTO, F, and R)
FA-5	127D8112G1	Control Panel Harness (Not Shown)
FA-6	127D8113G2	Control Panel Adder Harness (Not Shown)
FA-7	178B8459G1	Field Resistor Asm.
FA-8	178B8458G1	Diode Asm.
FA-9	244A7463P1	Fuse Block
FA-10	243A4597P1	Fuse 30 Amp
FA-11	243A4657P1	Fuse 20 Amp
FA-12	243A4719P1	Circuit Breaker

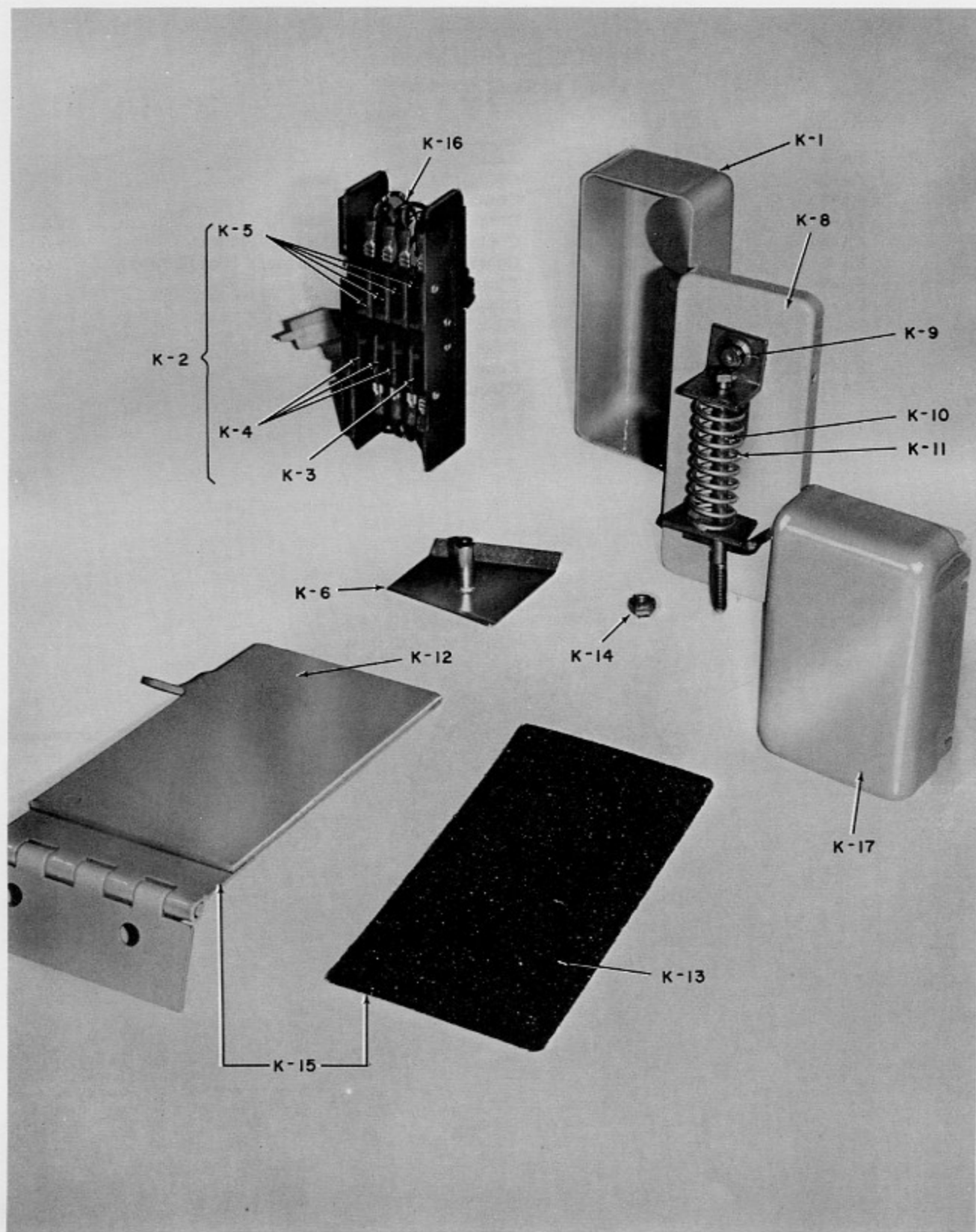

Fig. 15-6

SPEED CONTROL

<u>Ref. No.</u>	<u>Part No.</u>	<u>Description</u>
K-1	163B9997P2	Throttle Box
K-2*	178B8250G1	Rail & Switch Asm Less Harness (CE20AA, BA)
K-2*	178B8250G2	Rail & Switch Asm Less Harness (CE20CA)
K-3	211A3198P1	Start Switch, 3 Tabs
K-4*	211A3198P2	1A, 2A, 3A Switch, 2 Tabs, N. O. & Common (CE20AA, BA)
K-4*	211A3198P2	1A, 2A Switch, 2 Tabs N. O. & Common (CE20CA)
K-5*	211A3198P3	FW 1-4 Switch, 2 Tabs, N. C. & Common (CE20AA, BA)
K-5*	211A3198P3	FW 1-4 Switch, Switch 4, 2 Tabs, N. C. & Common (CE20CA)
K-6	243A4796G1	Throttle Cam
K-7	211A3577P3	Spring (Not Shown)
K-8	178B8249G2	Cover & Bracket Asm
K-9	243A4554P1	Push Nut
K-10	N22P21072B6	Screw (1/4 - 20 x 4 1/2")
K-11	211A3577P12	Spring
K-12	191B4516G2	Throttle Pedal (Hinged)
K-13	243A4825P2	Throttle Pedal Pad (Replaces 243A4825P1)
K-14	N264P21B6	Locknut (1/4-20)
K-15	247A7620G2	Pedal Asm (K12 + K13)
K-16*	178B8097G1	Harness, Throttle (CE20AA, BA)
K-16*	178B8480G1	Harness, Throttle (CE20CA)
K-17	163B9999P2	Cover
K-18*	158C9071G3	† Complete Throttle (CE20AA, BA)
K-18*	158C9071G2	† Complete Throttle (CE20CA)

†Includes all items shown on the previous page

\*When ordering this item it is imperative that care be taken to specify the model number and serial number of the tractor to insure your receiving the proper part.

REAR BATTERY  
COMPARTMENT, L.F.

TABLE OF CONTENTS

Rear Battery Compartment

All Large Frame Tractors

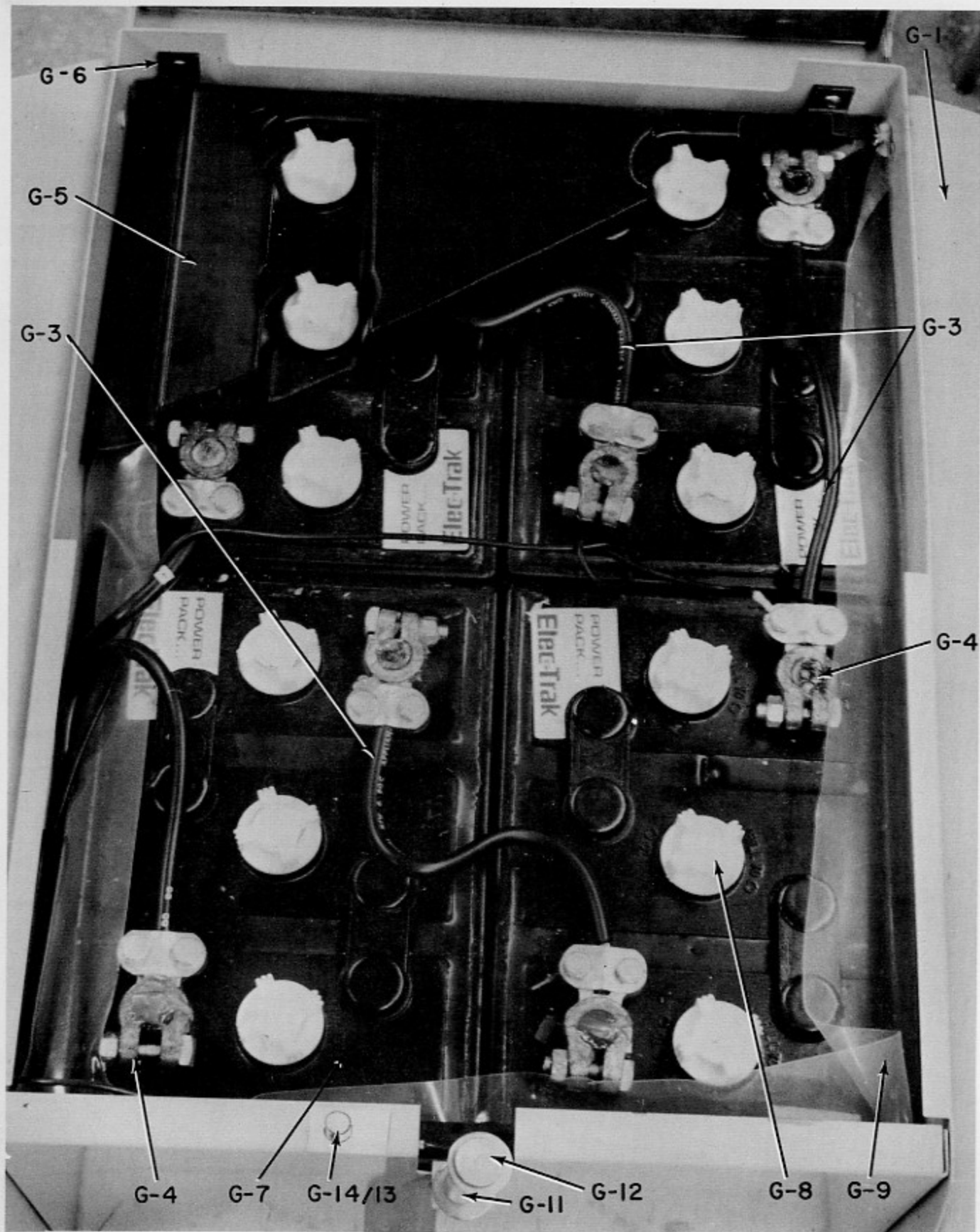

Fig. LF-1

REAR BATTERY COMPARTMENT

<u>Ref. No.</u>	<u>Part No.</u>	<u>Description</u>
G-1*	423D221G3	Rear Battery Box Assembly (Includes Fender) (E20)
G-1*	423D221G4	Rear Battery Box Assembly (Includes Fender) (I-5)
G-2	541C698P1	Battery Tray (Center Drain Hole)
G-2	155C8069P1	Battery Tray (Offset Drain Hole)
G-3	178B8165G1	Battery Cables (With Clamps)
G-4	243A4521P1	Battery Post Clamp
G-5	243A4522G1	Rear Battery Cover (Includes Decal)
G-6	163B9875G1	Battery Clamp Assembly
G-7*	243A4527P1	Standard Battery
G-7*	243A4724P1	Heavy Duty Battery
G-8*	243A4849P1	Battery Cap (Old - Heavy Duty)
G-8*	244A7420P1	Battery Cap (New - Heavy Duty & Standard)
G-9	155C8006P1	Rear Poly Bag
G-11	211A3577P1	Seat Spring
G-12	211A3191P1	Rivet
G-13 §	211A3420P1	Seat Switch
G-14 §	243A4790P1	Seat Switch

§ G-14 seat switch is of white plastic (pictured) and is used on many of the more recent tractors. It is not interchangeable with G-13 (not pictured) without additional machining. Therefore, before ordering it is imperative that a visual inspection be made.

\*When ordering this item it is imperative that care be taken to specify the model number and serial number of the tractor to insure your receiving the proper part.

CHARGERS

TABLE OF CONTENTS

FIGURE

TITLE

C-1

Charger for Models E20, I-5, E16, E15, E14,  
E12s, E12 and E12M

C-2

Charger for Models ER8, E8M and E10M

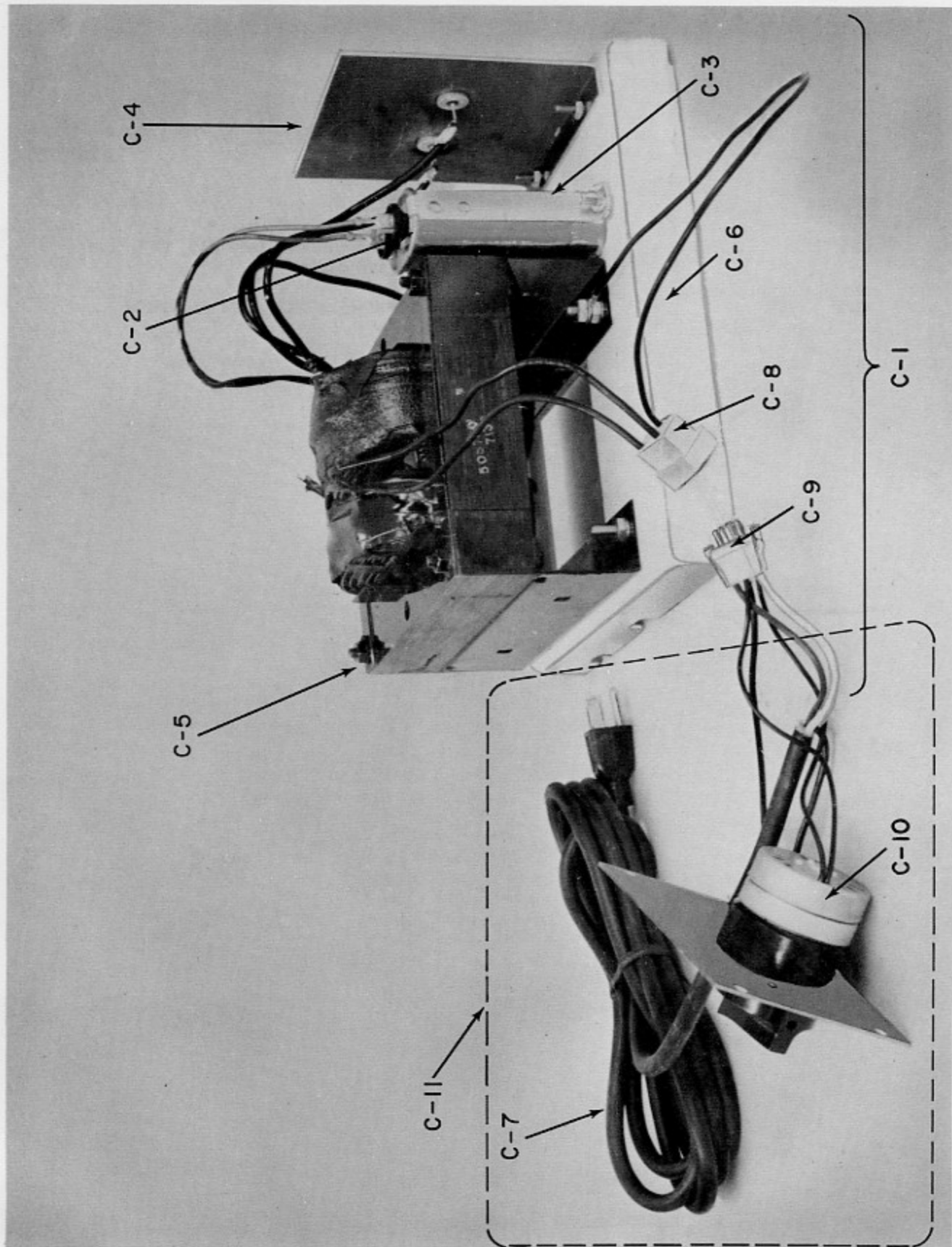

Fig. C-1

CHARGER

<u>Ref. No.</u>	<u>Part No.</u>	<u>Description</u>
C-1	423D211G2	Charger Subassembly (Includes Base, Transformer, Capacitor and Heat Sink) Used on E16RA, E15AA, E15BA E12AA Only
C-1A	423D225G1	Charger Subassembly (Includes Base, Transformer, Capacitor, and Heat Sink Assembly) Used on all Models Except as Noted Above
C-2	243A4514P1	Capacitor (Used with C-1)
C-2A	243A4653P1	Capacitor (Used with C-1A)
C-3	211A3510P1	Capacitor Bracket (Used with C-1)
C-3A	211A3510P2	Capacitor Bracket (Used with C-1A)
C-4	163B9905G1	Heat Sink Assembly (All Models)
C-5	163B9917P1	Transformer (Used with C-1)
C-5A	163B9955P1	Transformer (Used with C-1A)
C-6	541C932P1	Charger Base (All Models)
C-7	211A3555G1	Charger Cord Asm. (All Models)
C-8	243A4564P3	Plug (P-4) (All Models)
C-9	243A4568P3	Jack (J-4) (All Models)
C-10	211A3507P1	Timer (All Models)
C-11	163B9906G2	Timer Asm. (E20AA, BA, CA, CB, CC, DA, RA, ED, E15AA, BA, CA, CB, DA, EA, FA, GA, E16RA, RB, RD, E12AA, BA, CA, DA, EA, HA, E14RC, RD, RH)
C-11A	163B9906G4	Timer Asm. (Used on E20EA, EC, FA, E16AA, E15HA, JA, E14AA, RJ, E12JA, JD)

OVERSEAS MODELS ONLY  
50 CYCLE - 220 VOLTS

C-1	127D8086G1	Charger Subassembly (Includes Base, Transformer, Capacitor and Heat Sink Assembly)
C-2	243A4653P3	Capacitor
C-3	211A3510P3	Capacitor Brackets (2)
C-4	163B9905G1	Heat Sink Assembly
C-5	178B8424P1	Transformer
C-6	541C932P1	Charger Base
C-7	211A3555G1	Charger Cord Assembly
C-8	243A4564P3	Plug (P-4)
C-9	243A4568P3	Jack (P-4)
C-10	247A7427P1	Timer
C-11	178B8427G1	Timer Assembly

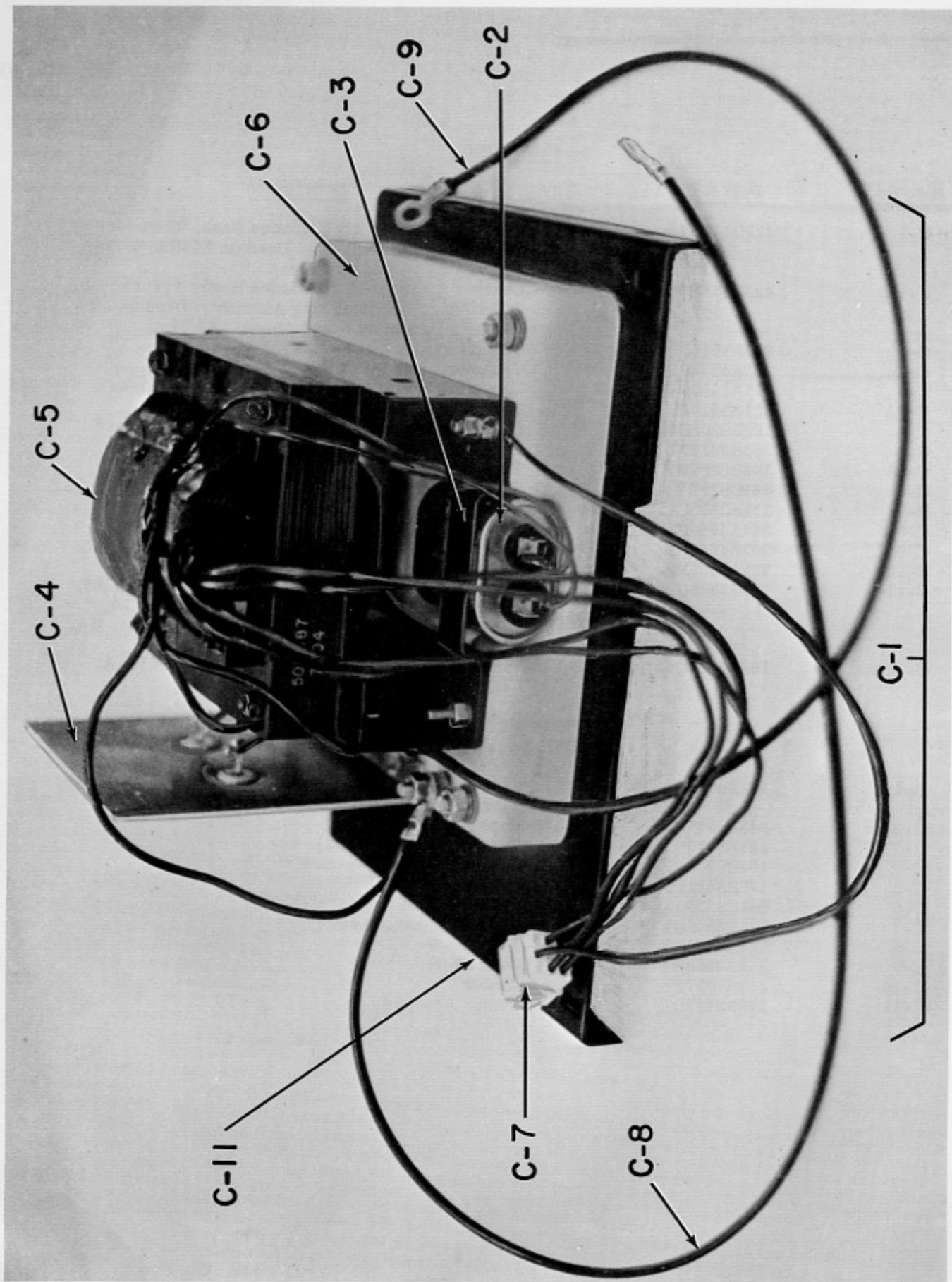

Fig. C-2

CHARGER

<u>Ref. No.</u>	<u>Part No.</u>	<u>Description</u>
C-1*	127D8024G4	Charger Subassembly (Includes Base, Transformer, Capacitor and Heat Sink Assembly) E10M
C-1*	127D8024G3	Same as Above for E8M
C-1*	127D8184G1	Same as Above for ER8
C-2*	243A4653P1	Capacitor (E10 Only)
C-2*	243A4653P2	Capacitor E8M + ER8
C-3	244A7282P1	Capacitor Clamp
C-4	163B9905G1	Heat Sink Assembly
C-5	163B9955P1	Transformer (E10 Only)
C-5	178B8146P1	Transformer E8M + ER8
C-6	155C8103P1	Charger Base
C-7	243A4564P3	Plug (P-4)
C-8*	244A7334G5	Wire #30-01 (Chgr. Neg) E8M + E10M
C-9*	244A7334G11	Wire (Chgr. Pos) E8M + E10M
C-10	211A3555G3	Charger Cord Assembly (Not Pictured)
C-11	155C8100P1	Bulkhead (Not Used on ER8)
C-8*	178B8297G2	Wire #30-01 (Charger Neg) ER8 Only
C-9*	178B8297G1	Wire #1-01 (Charger Pos) ER8 Only

Note: Capacitor inverted for ER8 only.

OVERSEAS MODEL ONLY  
50 CYCLE - 220 VOLTS

C-1	127D8096G1	Charger Subassembly (Includes Base, Transformer, Capacitor and Heat Sink Assembly)
C-2	243A4653P3	Capacitor
C-3	247A7476P1	Capacitor Clamp
C-4	163B9905G1	Heat Sink Assembly
C-5	178B8424P1	Transformer
C-6	155C8103P1	Charger Base
C-7	243A4564P3	Plug (P-4)
C-8	244A7334G5	Wire #30-01 (Chgr. Neg)
C-9	244A7334G11	Wire #1-04 (Charger Pos)
C-10	211A3555G1	Charger Cord Assembly
C-11	155C8100P1	Bulkhead

\*When ordering this item it is imperative that care be taken to specify the model number and serial number of the tractor to insure your receiving the proper part.

LIFTS

TABLE OF CONTENTS

FIGURE

TITLE

L-1

Front Lift, E20, I-5, E16, E15, E14, E12s, E12

L-2

Lift, E12M

L-3

Lift, E8M and E10M

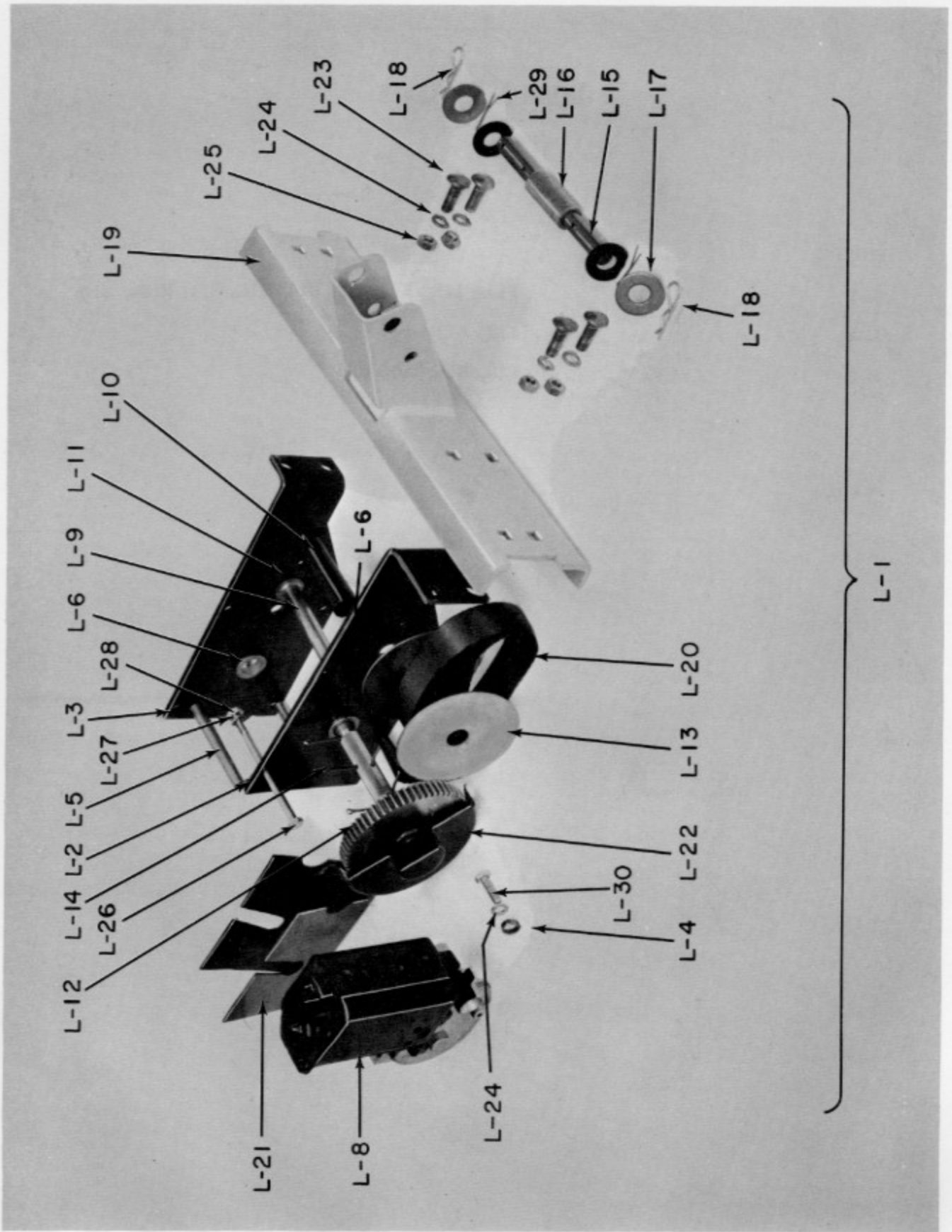

Fig. L-1

FRONT LIFT

<u>Ref. No.</u>	<u>Part No.</u>	<u>Description</u>
L-1A	422D808G2	Lift Assembly (E16RA, E15AA, E15BA, E12AA)
L-1B	423D217G1	Lift Assembly (All other models)
L-2	541C668P1	Support, Right
L-3	541C668P2	Support, Left
L-4	243A4550P1	Spacer
L-5	243A4550P2	Spacer
L-6	211A3540P3	Flanged Bearing
L-8	211A3561P1	Actuator
L-9A	211A3134P1	Stud (used on 422D808G2 only)
L-9B	211A3542P1	Shaft (used on 423D217G1 only)
L-10A	211A3137P1	Guide (used on 422D808G2 only)
L-10B	211A3543P1	Sleeve (used on 423D217G1 only)
L-11A	N210P21B6	Nut (used on 422D808G2 only) (1/4-20)
L-11B	243A4554P2	Pushnut (used on 423D217G1 only)
L-12	211A3539G1	Gear Assembly
L-13	211A3520P1	Washer
L-14	N503P916B6	Cotter Pin - (3/32" x 1")
L-15	211A3494P1	Shaft
L-16	211A3493P1	Spool
L-17	N402P45B6	Washer (1/2")
L-18	211A3256P3	Hairpin Cotter
L-19	191B4523G1	Lift Yoke
L-20	163B9802G1	Lift Strap and Clip
L-21	541C997P1	Tape Guard (used on 423D217G1 only)
L-21*	541C997P2	Tape Guard (used on 422D208G2 only)
L-22	541C907P1	Gear Cover
L-23	N657P23016B6	Carriage Bolt (5/16"-18 x 1")
L-24	N405P12C6	Lockwasher (5/16")
L-25	N210P23B6	Nut, Hex (5/16"-18)
L-26	N22P21068B6	Hex Hd. Bolt (used on 423D217G1 only) (1/4"-20 x 4 1/4")
L-27	N405P11C6	Lockwasher (used on 423D217G1 only)
L-28	N210P21B6	Nut (used on 423D217G1 only) (1/4-20)
L-29	211A3540P1	Flanged Bearing (not shown - used on end of motor shaft)
L-30	N22P21014B6	Bolt (1/4-20 x 7/8)
L-31	N57P16008B6	Pan Head Screw (#10-32 x 1/2)
L-32	N210P16B6	Nut (#10-32)
L-33	N405P9C6	Lockwasher (#10)

} used to hold  
gear cover in  
place on  
422D808G2  
only

\*Tape Guard 541C997P2 is needed for older lift assemblies.  
See Product Service Bulletin No. 7.

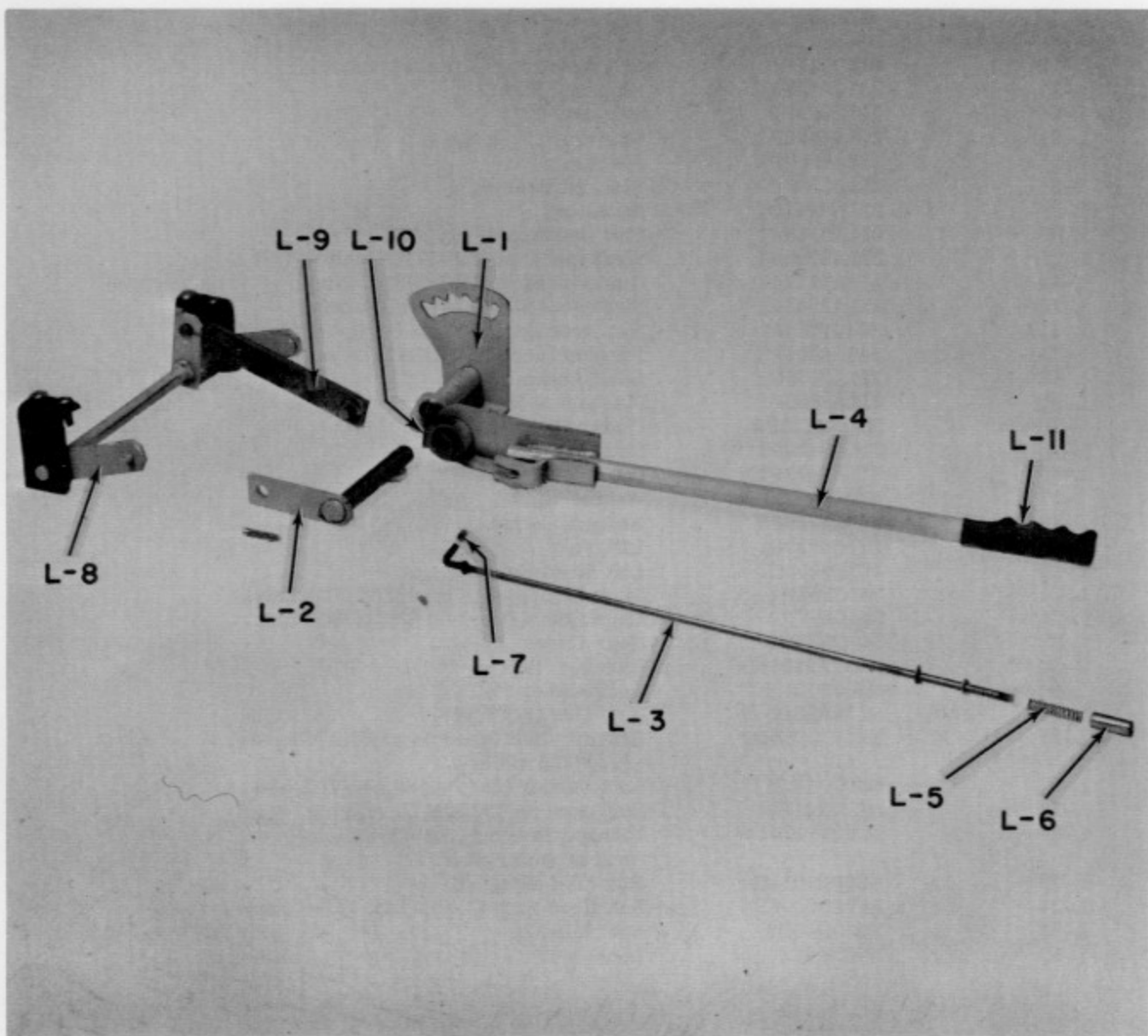

Fig. L-2

LIFT

<u>REF. NO.</u>	<u>PART NO.</u>	<u>DESCRIPTION</u>
L-1	178B8151G1	LIFT QUADRANT ASSEMBLY
L-2	244A7065G1	LIFT ARM ASSEMBLY
L-3	244A7081G1	ROD ASSEMBLY
L-4	178B8134G1	MANUAL LIFT HANDLE ASSEMBLY
L-5	211A3577P13	SPRING
L-6	244A7078P1	BUTTON
L-7	244A7212P1	ROLLER
L-8	178B8156G1	MOWER LIFT ARM ASSEMBLY
L-9	244A7135G1	CONNECTING LINK
L-10	N533P3124	DOWEL PIN (5/16 X 1 1/2)
L-11	244A7120P1	GRIP

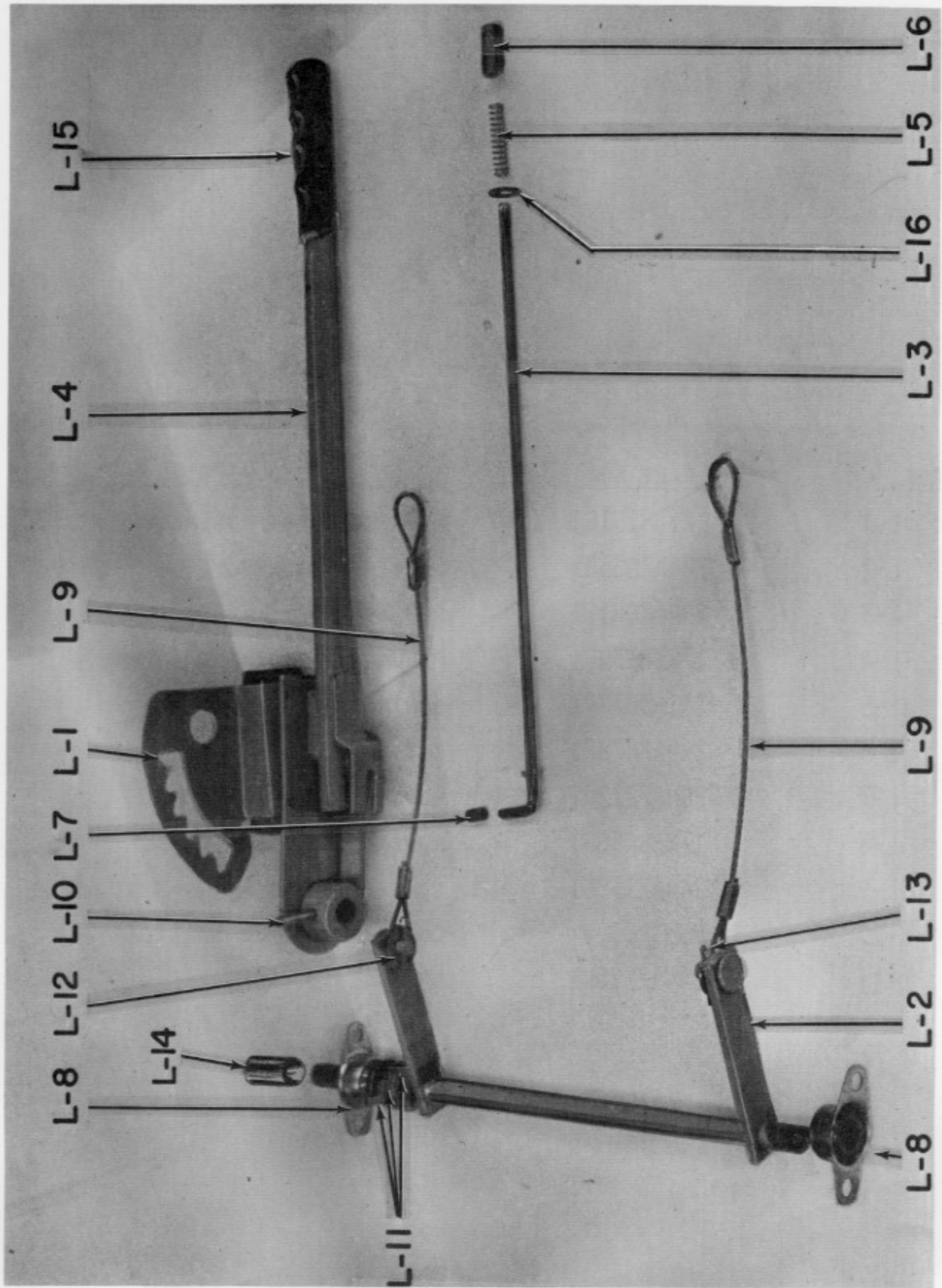

Fig. L-3

LIFT

<u>Ref. No.</u>	<u>Part No.</u>	<u>Description</u>
L-1	155C8106G1	Lift Quadrant Assembly
L-2	178B8176G1	Lift Arm Assembly
L-3	244A7081G2	Rod Assembly
L-4	178B8431G2	Lift Handle Assembly
L-5	211A3577P13	Spring
L-6	244A7078P1	Button
L-7	244A7212P3	Roller
L-8	211A3101P2	Bearing Assembly
L-9	244A7185P1	Lift Cable
L-10	N533P2524	Dowel Pin (1/4 x 1 1/2)
L-11	N402AP17B6	Washer (5/8)
L-12	N402AP43B6	Washer (3/8)
L-13	N503P1012B6	Cotter Pin (7/64" x 3/4")
L-14	243A4550P14	Spacer
L-15	244A7120P1	Grip
L-16	N402AP11B6	Washer (1/4")

BRAKES

TABLE OF CONTENTS

<u>FIGURE</u>	<u>TITLE</u>
B-1	Brake, Models E20, E15, E12s and E12
B-2	Brake, Models E20, I-5, E16, E15, E14, and E12
B-3	Brake, Model E12M
B-4	Brake, Models E8M and E10M

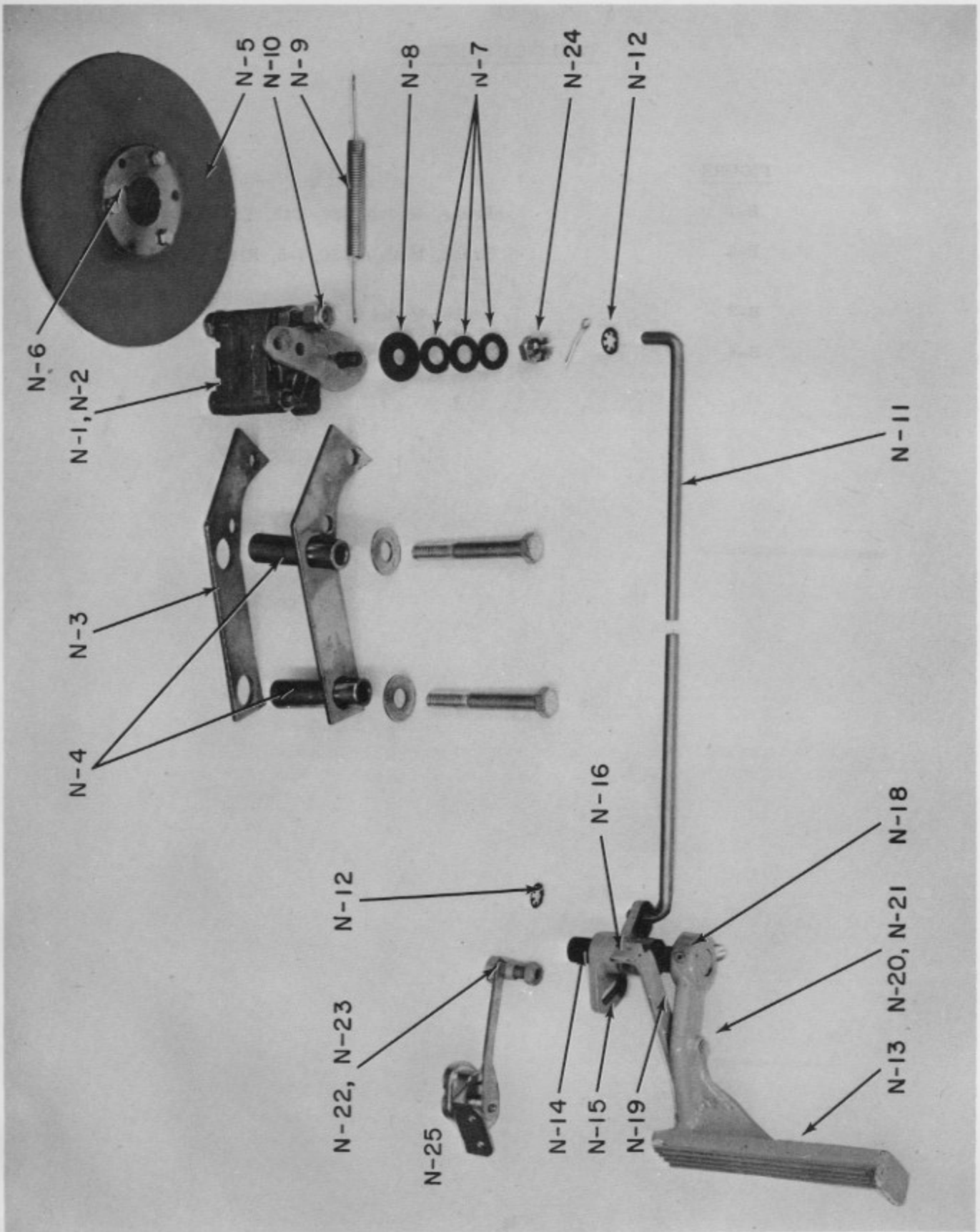

Fig. B-1

BRAKE

<u>Ref. No.</u>	<u>Part No.</u>	<u>Description</u>
N-1	211A3153G1	Disc Brake and Caliper
N-2	211A3593P1	Friction Pad Set
N-3	211A3469P1	Bracket
N-4	211A3470P1	Spacer
N-5	211A3154G1	Disk and Hub
N-6	N3400P606	Key (3/16 x 3/4 Woodruff)
N-7	243A4582P3	Washer Belleville (3 Required)
N-8	243A4642P1	50 Mil. Washer
N-9	211A3489P1	Return Spring
N-10	211A3582P1	Locknut, Hex
N-11	211A3468P1	Brake Rod
N-12	211A3488P1	Push Nut (Spring Clip)
N-13	542C893P2	Brake Pedal
N-14	211A3410P1	Shaft
N-15	163B9899P1	Brake Pawl
N-16	N533P1612	Dowel Pin (5/32 x 3/4)
N-17	N402AP15B6	Washer (1/2")
N-18	N533P1618	Dowel Pin (5/32 x 1 1/8)
N-19	211A3467P1	Lever
N-20	211A3584P1	Curved Washer
N-21*	243A4773P1	Rivet
N-21*	211A3583P1	Screw (10-32 x 1/2)
N-22	211A3504P1	Shoulder Screw
N-23	N264P21B6	Locknut (1/4-20)
N-24	243A4959P1	Castle Nut
N-25	211A3481P1	Brake Switch

\*Both rivet and screw have been used to attach parking brake lever to brake pedal. Specify correctly when ordering.

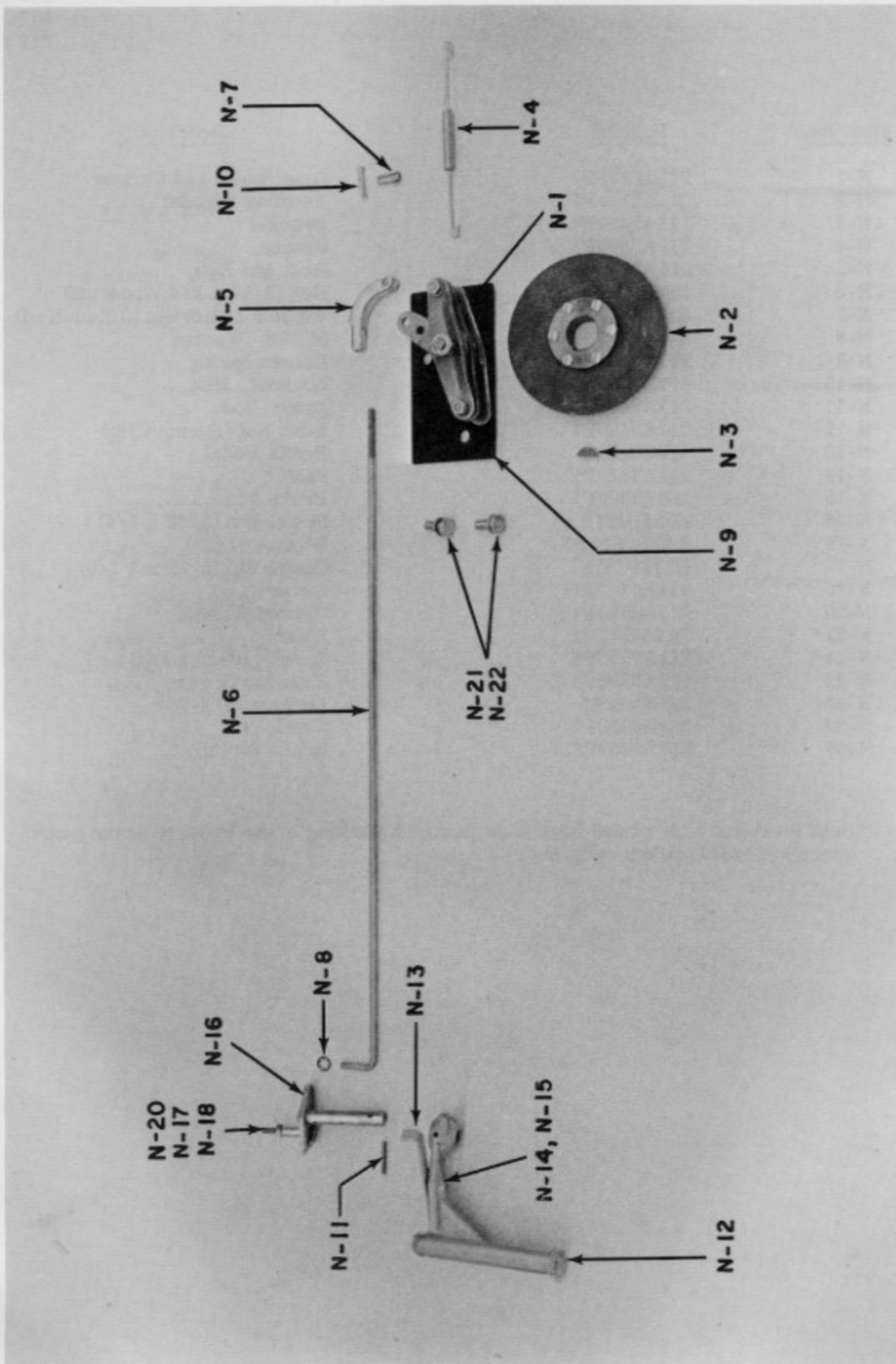

Fig. B-2

E20EA, EC, ED, FA, RA  
 I-5  
 E16AA, RA, RB, RD  
 E15HA, JA  
 E14AA, RC, RD, RH, RJ  
 E12JA, JD

BRAKE

<u>Ref. No.</u>	<u>Part No.</u>	<u>Description</u>
NA-1	178B8150G2	Brake Sub Asm.
NA-2	244A7069G1	Disk & Hub Asm.
NA-3	N3400P606	Key (Woodruff - 3/16 x 3/4")
NA-4	247A7332P1	Return Spring
NA-5	247A7331P1	Clevis
NA-6	244A7126P2	Brake Rod
NA-7	211A3505P13	Clevis Pin
NA-8	211A3488P1	Push Nut
NA-9	247A7330P1	Mounting Plate
NA-10	N503P912	Cotter Pin (3/32" x 3/4")
NA-11	N533P1618	Dowel Pin (5/32" x 1 1/8")
NA-12	542C893P2	Brake Pedal
NA-13	211A3467P1	Lever
NA-14	211A3584P1	Curved Washer
NA-15	243A4773P1	Rivet
NA-16	243A4862G1	Shaft Asm.
NA-17	243A4550P10	Spacer
NA-18	N264P21B6	Lock Nut Hex (1/4-20)
NA-19	243A4550P11	Spacer (Not Shown)
NA-20	N62P21024B6	Carriage Bolt (1/4"-20 x 1 1/2")
NA-21	N22P25018	Bolt Hex Head (3/8-16 x 1 1/8")
NA-22	N405P43	Lock Washer (3/8")
NA-23	163B9876G2	Brake Pedal Assembly (Includes 12, 13, 14, 15)

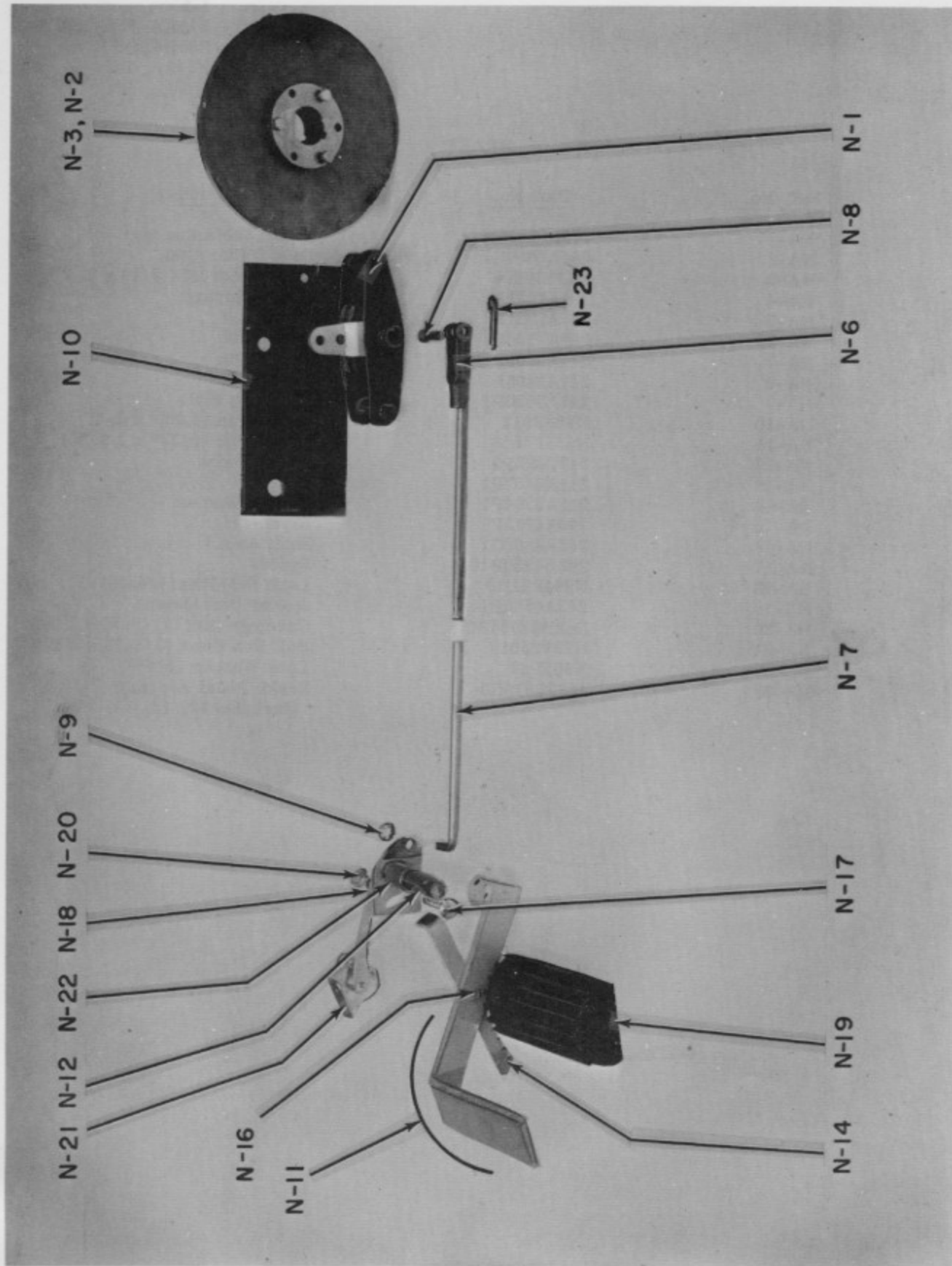

Fig. B-3

BRAKE

<u>Ref. No.</u>	<u>Part No.</u>	<u>Description</u>
N-1	178B8150G1	Brake Sub-Assembly
N-2	244A7069G1	Disk and Hub
N-3	N3400P606	Key (3/16 x 3/4 Woodruff)
N-4	211A3489P1	Return Spring (Not pictured)
N-5	244A7143G1	Clevis and Rod Assembly (Includes N-6, N-7)
N-6	244A7168P1	Clevis
N-7	244A7126P1	Brake Rod
N-8	211A3505P13	Clevis Pin
N-9	211A3488P1	Push Nut (Spring Clip)
N-10	244A7127P1	Mounting Plate
N-11	244A7129G1	Brake Pedal Assembly (Includes N-14, N-15, N-16, N-19, and N-22)
N-12	244A7130G1	Shaft Assembly
N-13	N533P1618	Dowel Pin (5/32 x 1 1/8)
N-14	211A3467P1	Lever
N-15	211A3584P1	Curved Washer (Not pictured)
N-16	243A4773P2	Rivet
N-17	N657P21024B6	Carriage Bolt (1/4-20 x 1 1/2)
N-18	243A4550P10	Spacer
N-19	244A7159P1	Brake Pedal Pad
N-20	N264P21B6	Locknut (1/4-20)
N-21	244A7131P1	Brake Switch
N-22	244A7128P1	Bushing
N-23	N503P912	Cotter Pin (3/32" x 3/4")

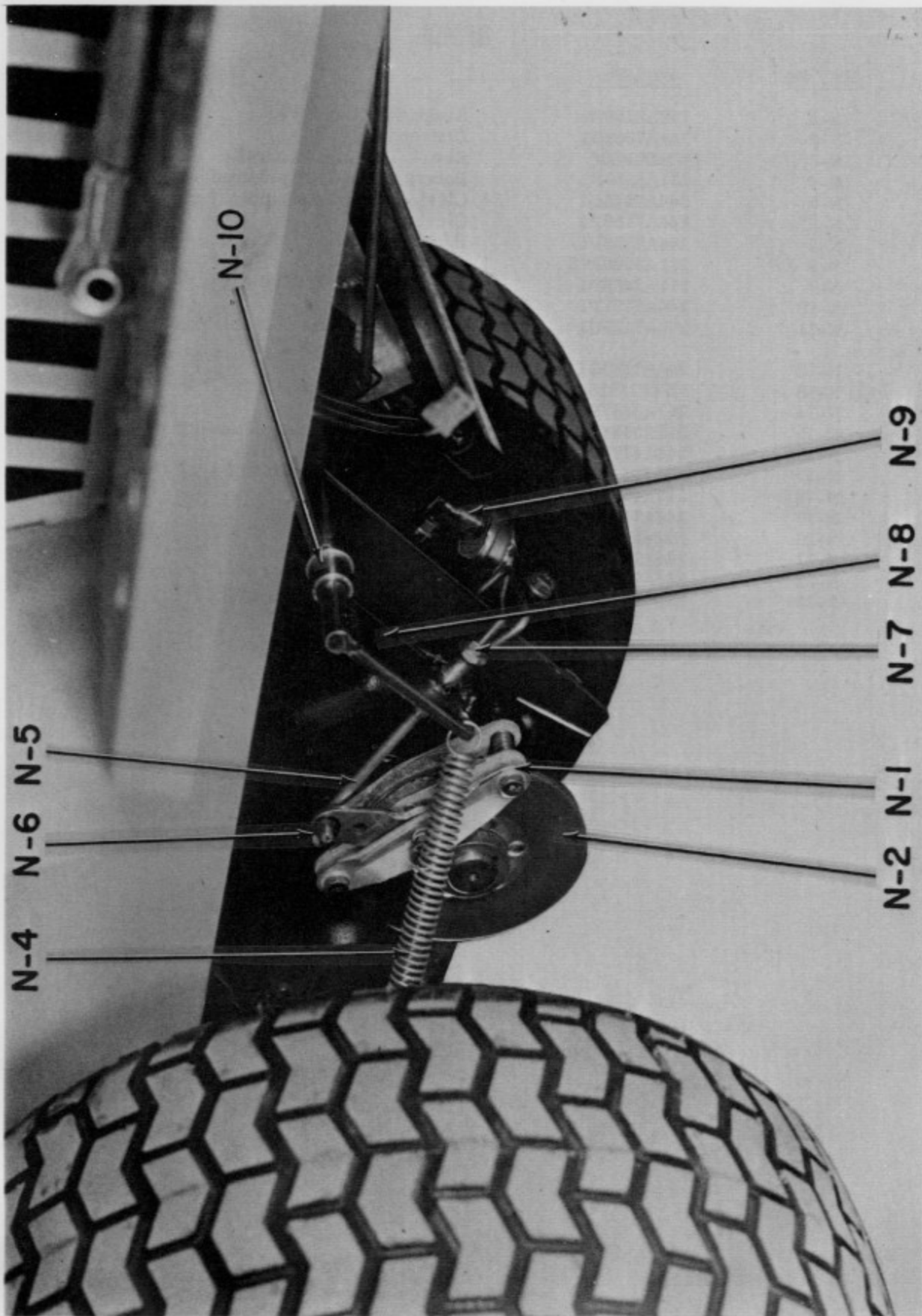

Fig. B-4

BRAKE

<u>REF. NO.</u>	<u>PART NO.</u>	<u>DESCRIPTION</u>
N-1	155C8149G1	BRAKE ASSEMBLY
N-2	244A7301G1	DISK AND HUB
N-3	N3400P606	KEY (3/16 X 3/4 WOODRUFF)
N-4	244A7415P1	RETURN SPRING
N-5	244A7409P1	BRAKE ROD
N-6	211A3488P1	PUSH NUT
N-7	244A7414P1	NUT, BRAKE ROD
N-8	178B8278G1	ARM AND SHAFT ASM
N-9	211A3481P1	CLUTCH SWITCH
N-10	211A3540P5	FLANGED BEARING

MOWERS

CONTENTS

FIGURE

TITLE

M-1	Rotary Mower Assembly
M-2	Rotary Mower Rear Discharge Kit
M-3	Rotary Mower Side Discharge Kit
M-4	E12M Mid-Mount Rotary Mower
M-5	E8M-E10M Mid-Mount Mower
M-6	ER8 Mower Assembly
M-7	Walk-Behind Lawn Mower
M-8	56" Front Mounted Gang Mower
M-9	Sickle Bar Mower Drive
M-10	Sickle Bar Mower

MOWER ASSEMBLY -  
TOP VIEW

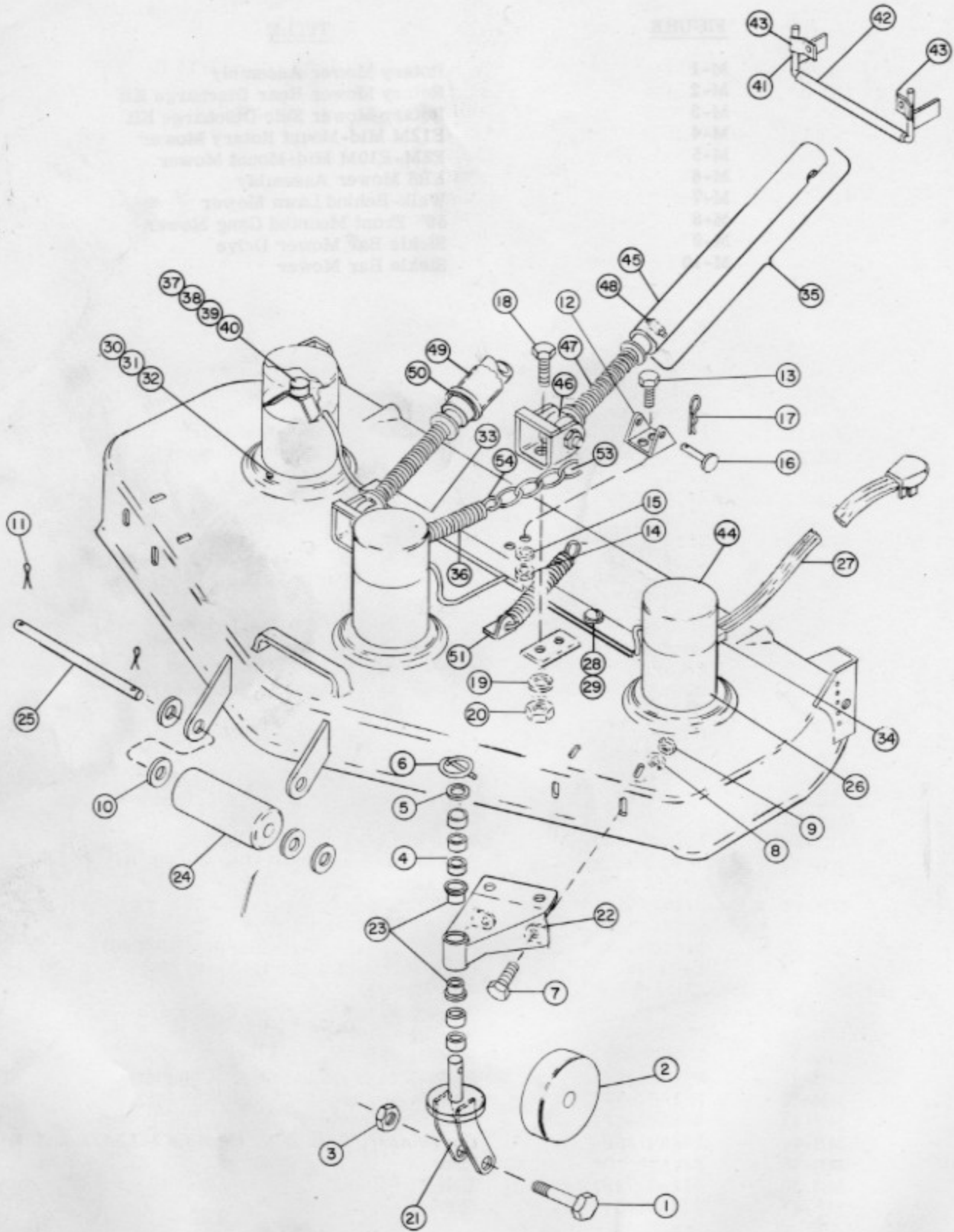

Fig. M-1

ROTARY MOWER ASSEMBLY

<u>Ref. No.</u>	<u>Part No.</u>	<u>Description</u>
MB-1	N22P290568	Bolt, Hex Hd. 1/2-13 x 3 1/2
MB-2	211A3220P1	Wheel, Caster
MB-3	N264P29B6	Lock Nut, Hex 1/2-13
MB-4	211A3255P1	Spacer
MB-5	N402AP18B6	Washer, Plain 1 3/8 OD x 13/16 ID
MB-6	211A3471P1	Spring Pin
MB-7	N22P23018B6	Bolt, Hex Hd. 5/16-18 x 1 1/8
MB-7	N22P23012B6	Bolt, Hex Hd. 5/16-18 x 3/4
MB-8	N405P12C6	Lockwasher 5/16
MB-9	N402AP1886	Nut, Hex 5/16-18
MB-10	243A4642P3	Washer, Plain
MB-11	N503P1216B6	Cotter Pin 1/8 x 1
MB-12	211A3231P1	Lift Clevis
MB-13	N22P21010B6	Bolt, Hex Hd. 1/4-20 x 5/8
MB-14	N210P21B6	Nut, Hex 1/4-20
MB-15	N405P11C6	Lockwasher 1/4
MB-16	211A3505P3	Clevis Pin
MB-17	243A4543P1	Hair Pin Cotter
MB-18	N22P25014B6	Bolt, Hex Hd. 3/8-16 x 7/8
MB-19	N405P13C6	Lockwasher 3/8
MB-20	N258P25B6	Nut, Hex 3/8-16
MB-21	178B8195P1	Yoke, Caster (Fabricated type)
MB-22	541C926G1	Caster Support (Fabricated type)
MB-22	542C895P1	Caster Support (Cast type)
MB-23	211A3236P1	Caster Bearing
MB-24	178B8489P1	Roller (Front) (Rubber)
MB-25	243A4643P1	Shaft (Front)
MB-26	211A3435G1	Motor 3 1/4 OD Cover (New) - 247A7671P1 (Factory Rebuilt)
MB-26+	158C9011P1	Motor 4 3/8 OD Cover Heavy Duty (New) - 247A7673P5 (Factory Rebuilt)
MB-26+	158C9017P1	Motor (Replaces 541C971P1) New - 243A4673P1 (Factory Rebuilt)
MB-27+	178B8077G1	Wiring Harness (For Use With 26+)
MB-28	N80P15005B6	Screw Pan Hd. Phillips 8-32 x 5/16
MB-29	N405P8C6	Lockwasher #8
MB-30	N22P21014B6	Bolt, Hex Hd. 1/4-20 x 7/8
MB-31	N210P21B6	Nut, Hex 1/4-20
MB-32	N405P11C6	Lockwasher 1/4
MB-33	541C909P1	Wire Cover
MB-34	541C910P1	Wire Box
MB-34+	541C910P2	Wire Box (For Use With 26+)
MB-35	542C872G1	Mower Arm Assembly (See 45, 46, 47, 48 For Breakdown)
MB-36	211A3455P1	Spring Helper
MB-37	211A3530P1	Circuit Breaker
MB-37	211A3530P3	Circuit Breaker for Motor No. 158C9011P1
MB-37+	Included Internally	Circuit Breaker (For Use with 26+)
MB-38	N80P13010B6	Screw, Pan Hd. Phillips 6-32 x 5/8
MB-39	N402AP7B6	Washer, Plain #6
MB-40	N402P7C6	Lockwasher #6
MB-41	541C961G1	Front Mower Guide Assy. (Complete)
MB-42	243A4739P1	Sleeve
MB-43	243A4786P1	Clamp (2 Required)
MB-44	243A4736P4	Cover Assy. With Hdw. (Models 26AA42B and D)
MB-45	247A7607G1	Arm
MB-46	211A3271P1	Ball Rod End
MB-47	243A4645P1	Spring



ROTARY MOWER ASSEMBLY (Cont'd)

<u>Ref. No.</u>	<u>Part No.</u>	<u>Description</u>
MB-48	N533P1315	Roll Pin
MB-49	244A7215P1	Mower Wear Sleeve
MB-50	244A7216P1	Retainer
MB-51	211A3465P1	Spring Bracket
MB-53	244A7112P1	Chain Oval Link
MB-54	244A7113P1	"S" Hook
MB-56	244A7260G1	Caster Asm. (Parts 1, 2, 3, 21)
MB-57	244A7114G1	Spring Assembly (Parts 36, 53, 54)

(1) May be ordered as total replacement kit 178B8406G1 (three (3) motors, harness, circuit breakers, and hardware).



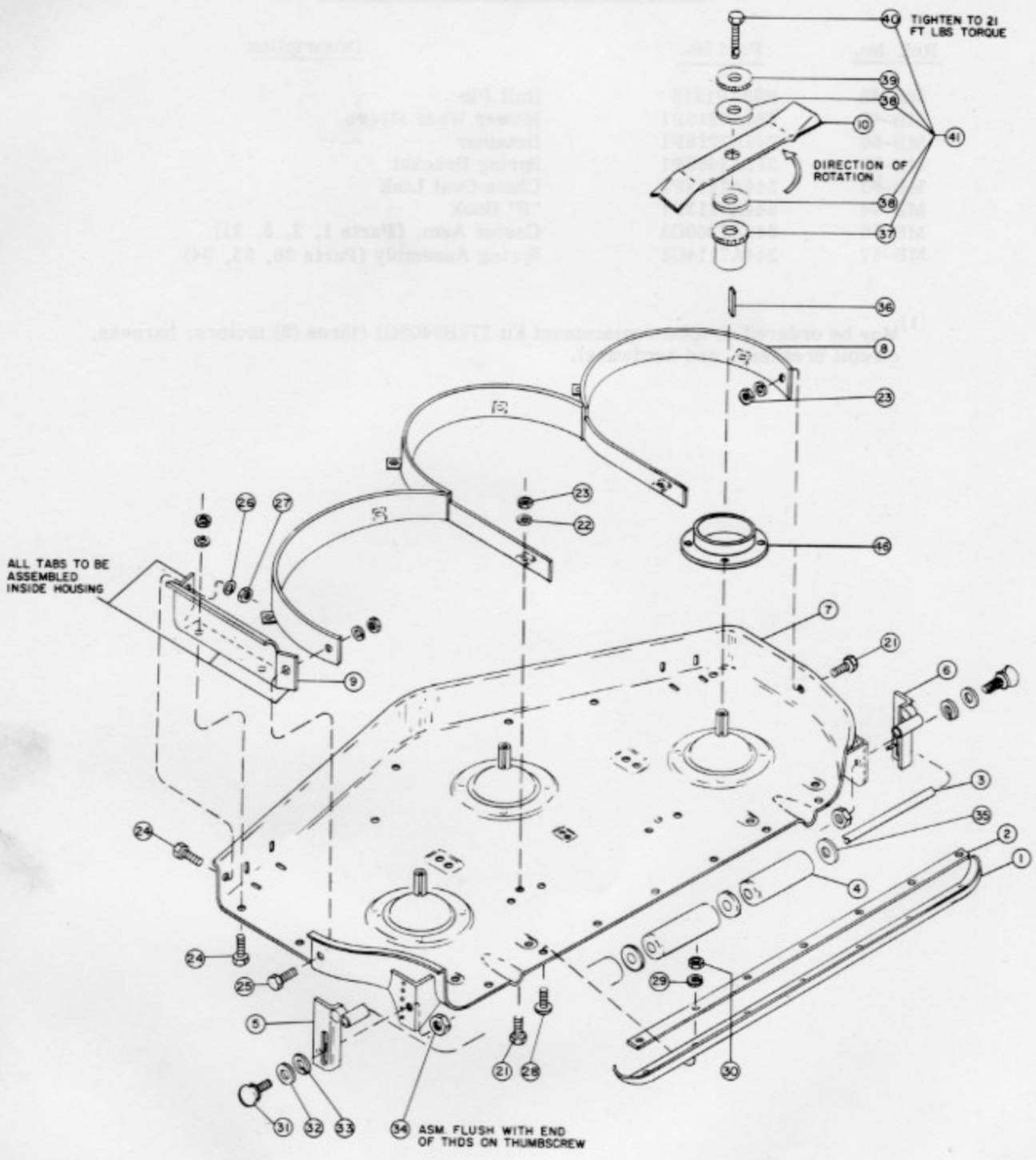

REFERENCE NUMBER IS NUMBER ON DRAWING PREFIXED BY MR

Fig. M-2

ROTARY MOWER REAR DISCHARGE ASSEMBLY

<u>Ref. No.</u>	<u>Part No.</u>	<u>Description</u>
MR-1	243A4517P1	Rear Mower Flap
MR-2	243A4520P1	Strip
MR-3	243A4608P1	Shaft (Roller)
MR-4	178B8489P1	Roller (Rubber) Model PA, RA
MR-5	163B9801G1	Adjuster Assy. (Right)
MR-6	163B9801G2	Adjuster Assy. (Left)
MR-7	587E958G3	Housing Assy. (Deck)
MR-8	423D204G1	Baffle (Rear)
MR-9	211A3554G1	Cover Assembly
MR-10	163B9871P1	Blade (Mower)
MR-21	See Note 1	Bolt, Hex Hd. 1/4-20
MR-22	See Note 1	Lockwasher 1/4
MR-23	See Note 1	Nut, Hex 1/4-20
MR-24	See Note 1	Bolt, Hex Hd. 1/4-20 x 5/8
MR-25	See Note 1	Bolt, Hex Hd. 1/4-20 x 3/4
MR-26	See Note 1	Lockwasher 1/4
MR-27	See Note 1	Nut, Hex 1/4-20
MR-28	See Note 1	Screw, Pan Hd. Phillips 10-32 x 7/16
MR-29	See Note 1	Lockwasher #10
MR-30	See Note 1	Nut, Hx. 10-32
MR-31	243A4571P2	Thumbscrew 3/8-16
MR-32	See Note 1	Washer, Plain 3/8 ID
MR-33	See Note 1	Lockwasher 3/8
MR-34	See Note 1	Locknut, Hex 3/8-16
MR-35	243A4642P3	Washer, Plain 11/16 ID x 1 3/4 OD
MR-36	211A3565P1	Key 5/32 Sq. x 5/8
MR-37	243A4577P1	Clutch Body
MR-38	243A4576P1	Washer, Fibre 2 Required per Blade)
MR-39	243A4578P1	Clutch Washer
MR-40	211A3564P1	Screw, Self-Locking Cap
MR-41	163B9932G1	Clutch Assy. (Nos. 37, 38 (2), 39, 40)
MR-42	243A4519G1	Grass Deflector Asm.
MR-43	211A3491G1	Rear Discharge Kit
MR-44	211A3514P1	Caution Decal
MR-45	163B9947G3	Rear Roller Asm.
MR-46	247A7665P1	Flange

(1) Not stocked, order locally. For bolt and screw replacement, use Grade 5 or better.

ROTARY MOWER BEAR INCHARGE ASSEMBLY

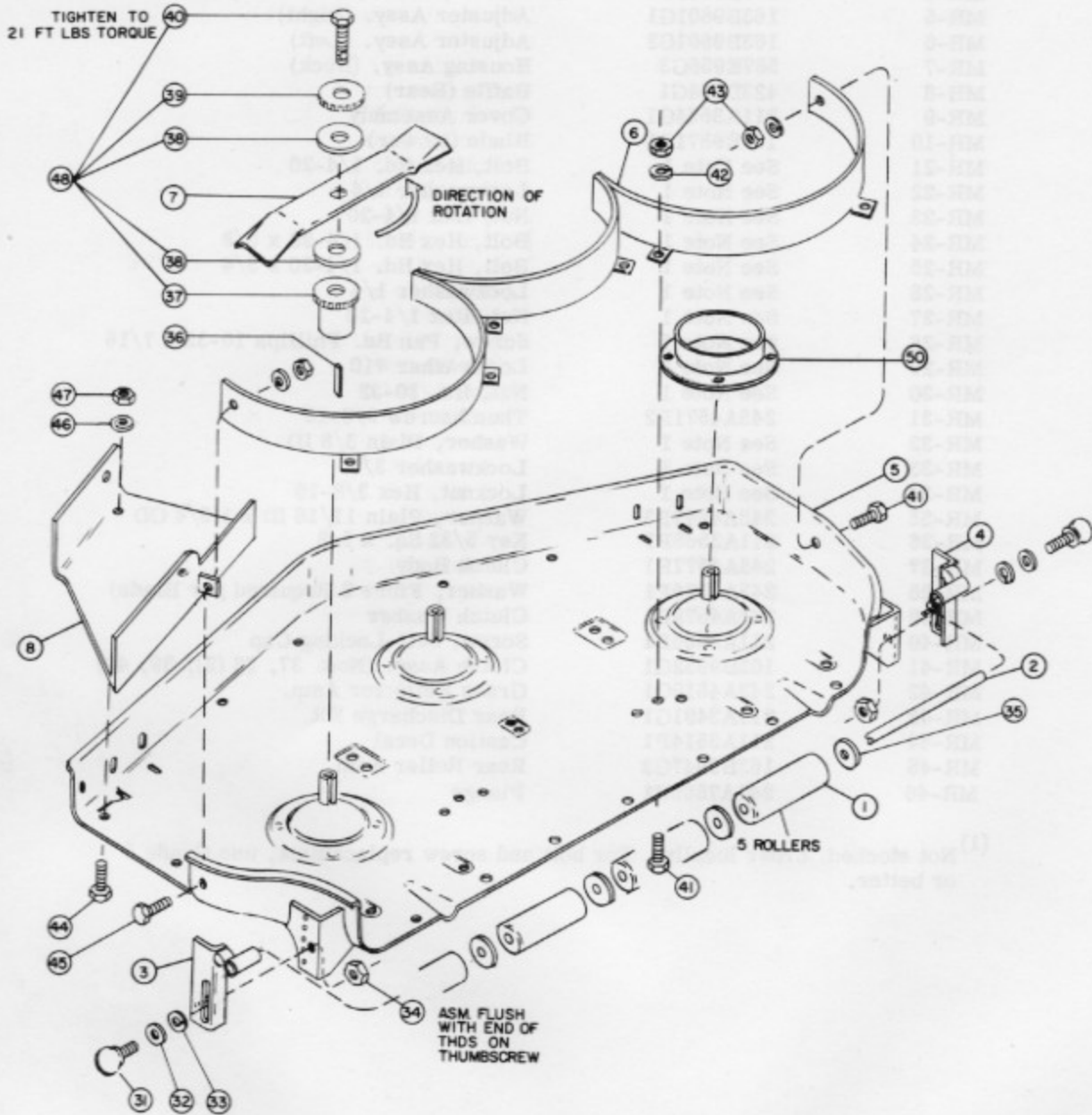

REFERENCE NUMBER IS NUMBER ON DRAWING PREFIXED BY MS

Fig. M-3

ROTARY MOWER SIDE DISCHARGE ASSEMBLY

<u>Ref. No.</u>	<u>Part No.</u>	<u>Description</u>
MS-1	178B8489P1	Roller (Rubber)Model MA, RA
MS-2	243A4608P1	Shaft (Roller)
MS-3	163B9801G1	Adjuster Assembly (Right)
MS-4	163B9801G2	Adjuster Assembly (Left)
MS-5	587E958G3	Housing Assembly (Deck)
MS-6	587E934G1	Baffle (Side)
MS-7	163B9871P1	Blade (Mower)
MS-8	541C906G1	Discharge Chute Assembly
MS-8	244A7447G1	Discharge Chute Assembly (Model BA)
MS-8	178B8465G1	Discharge Chute Assembly (Model CA - MA)
MS-31	243A4571P2	Thumbscrew 3/8-16
MS-32	See Note 1	Washer, Plain 3/8 In.
MS-33	See Note 1	Lockwasher 3/8
MS-34	See Note 1	Locknut, Hex 3/8-16
MS-35	243A4642P3	Washer, Plain 11/16 ID x 1 3/4 OD
MS-36	211A3565P1	Key 5/32 Sq. x 5/8
MS-37	243A4577P1	Clutch Body
MS-38	243A4576P1	Washer, Fibre
MS-39	243A4578P1	Clutch Washer
MS-40	211A3564P1	Screw, Self-Locking Cap
MS-41	See Note 1	Bolt, Hex Hd. 1/4-20 x 5/8
MS-42	See Note 1	Lockwasher 1/4
MS-43	See Note 1	Nut, Hex 1/4-20
MS-44	See Note 1	Bolt, Hex Hd. 1/4-20 x 5/8
MS-45	See Note 1	Bolt, Hex Hd. 1/4-20 x 3/4
MS-46	See Note 1	Lockwasher 1/4
MS-47	See Note 1	Nut, Hex 1/4-20
MS-48	163B9932G1	Clutch Assy. (Nos. 37, 38, 39, 40)
MS-49	211A3491G3	Side Discharge Kit
MS-50	247A7665P1	Flange

(1) Not stocked, order locally. For bolt and screw replacement, use Grade 5 or better.

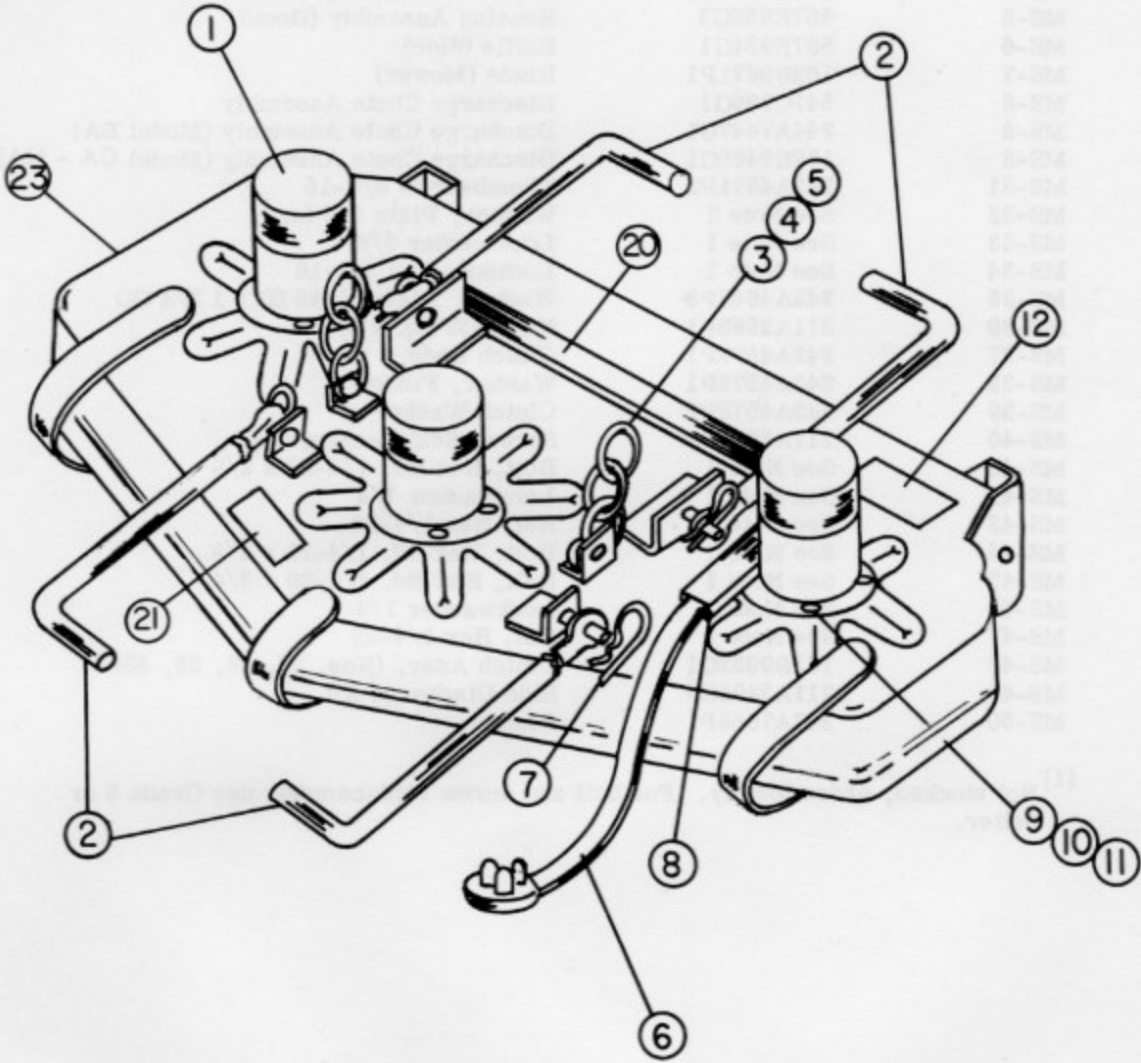

Fig. M-4

E 12M-MID MOUNT ROTARY MOWER

<u>Ref. No.</u>	<u>Part No.</u>	<u>Description</u>
MM-1	155C8075P1	Mower Motor (New) - 247A7673P2 (Reconditioned)
MM-2	244A7073G1	Rod Assembly
MM-3	244A7082P1	Chain
MM-4	N402AP42B6	Washer (5/16 Dia)
MM-5	N503P1012B6	Cotter Pin (7/16 x 3/4)
MM-6	178B8169G1	Wire Harness
MM-7	243A4543P1	Hair Pin Cotter
MM-8	155C8079P1	Wire Box
MM-9	N22P21014B6	Bolt (1/4-20 x 7/8)
MM-10	N210P21B6	Nut (1/4-20)
MM-11	N405P11C6	Lockwasher (1/4")
MM-12	211A3512P1	Caution Decal
MM-13	163B9871P3	Blade (Not Pictured)
MM-14	163B9932G2	Clutch Asm. (Not Pictured)
MM-15	243A4577P2	Clutch Body (Part of MM-14)
MM-16	243A4576P1	Washer, Fiber (Part of MM-14)
MM-17	243A4578P1	Clutch Washer (Part of MM-14)
MM-18	211A3564P3	Screw, Self Locking Cap (Part of MM-14)
MM-19	211A3565P1	Key (Furnished with Motor MM-1)
MM-20	541C909P1	Wire Cover
MM-21	211A3513P1	Caution Decal
MM-22	163B9947G3	Rear Roller Asm. (Consists of MR-3, MR-4, MR-5, MR-6, MR-35)
MM-23	127D8004G1	Mower Housing

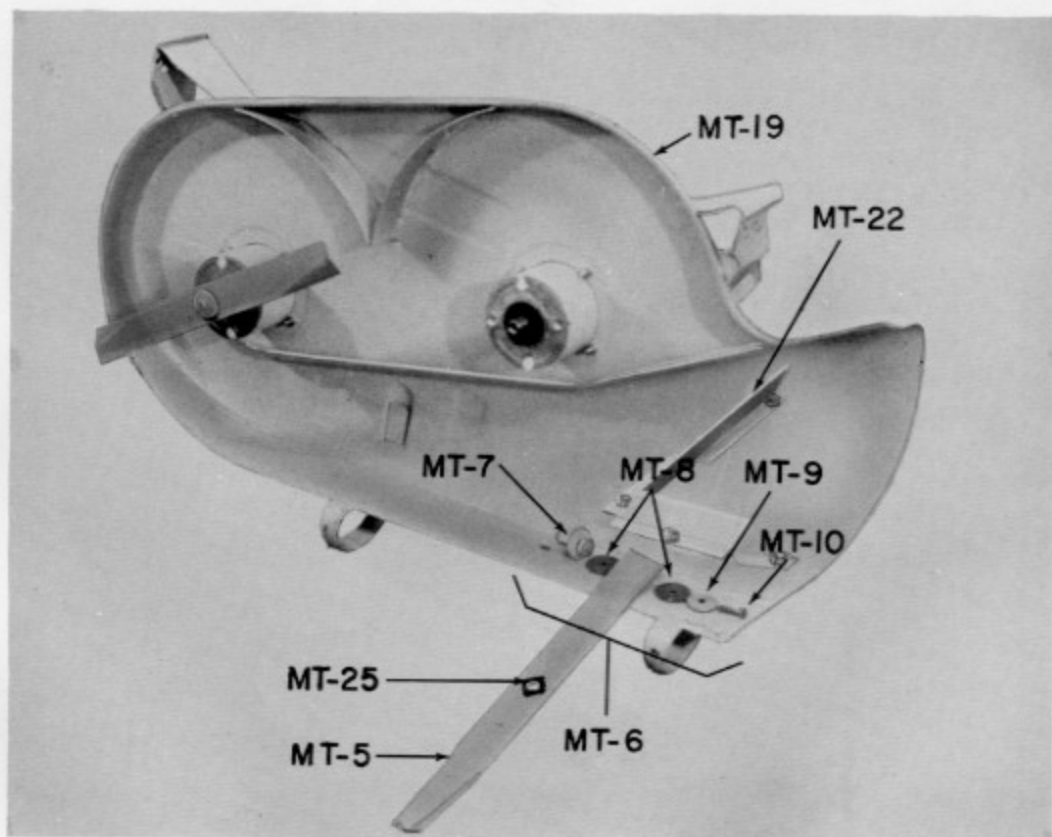
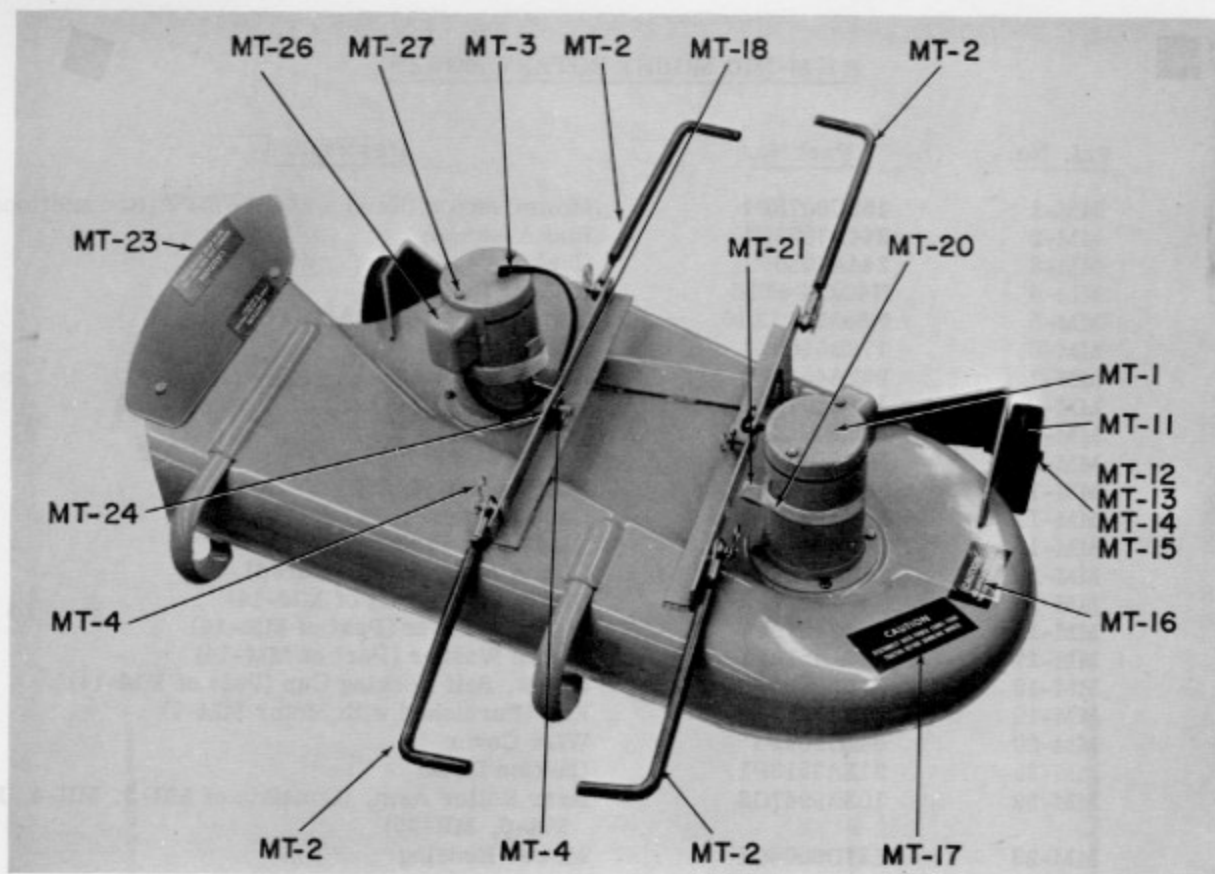
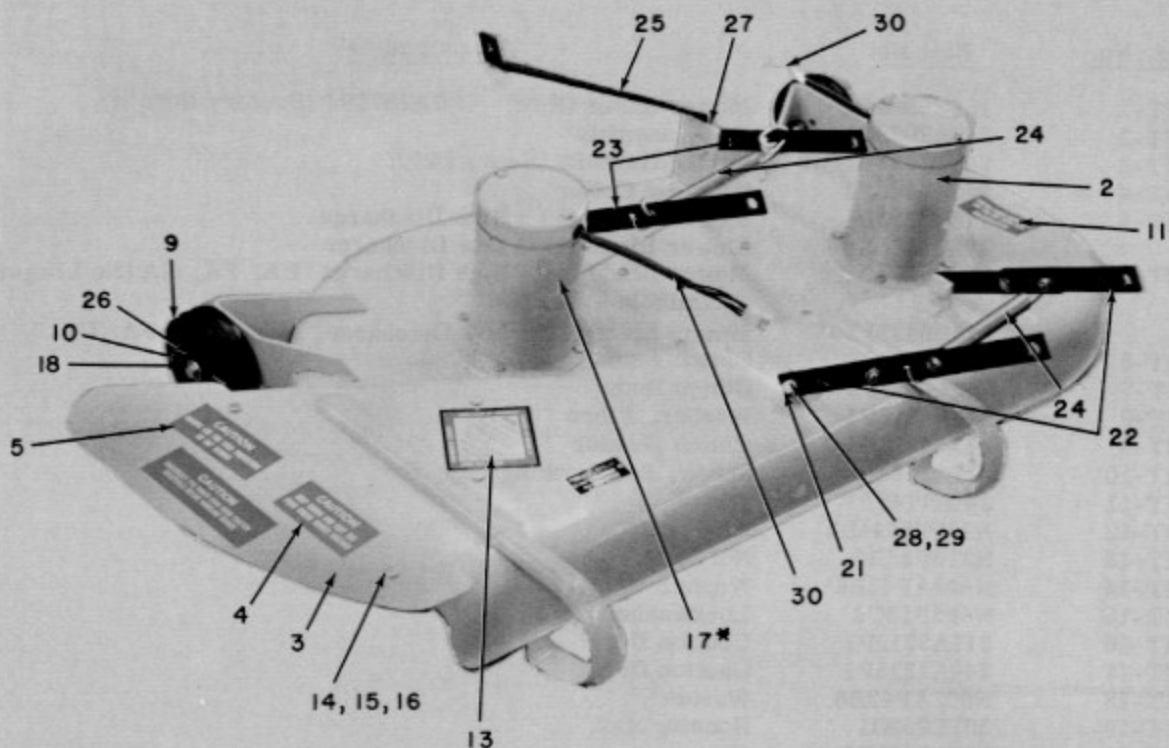

Fig. M-5

E8M - E10M ROTARY MOWER - MID MOUNT

<u>Ref. No.</u>	<u>Part No.</u>	<u>Description</u>
MT-1	155C8086P1	Mower Motor (New) - 247A7673P4 (Factory Rebuilt)
MT-2	244A7073G1	Rod Assembly
MT-3	247A7728G1/G2	Wiring Harness (Heavy Duty)
MT-4	243A4543P1	Hair Pin Cotter
MT-5	178B8175P1	Mower Blade (30°) High Discharge
	178B8175P2	Mower Blade (15°) Low Discharge
MT-5	178B8497P1	Mower Blade (30°) High Discharge EA, FA, GA (No Longer Available - Use P2)
	178B8497P2	Mower Blade (15°) Low Discharge. Model EA, FA, GA
MT-6	163B9932G2	Clutch Asm.
MT-7	243A4577P2	Clutch Body
MT-8	243A4576P1	Washer, Fibre
MT-9	243A4578P1	Clutch Washer
MT-10	211A3564P3	Screw, Self Locking Cap
MT-11	244A7145P1	Wheel
MT-12	N22P25044B6	Bolt, Hex
MT-13	N210P25B6	Nut
MT-14	N402AP43B6	Washer
MT-15	N405P13C6	Lockwasher
MT-16	211A3512P1	Caution Decal
MT-17	244A7325P1	Caution Decal
MT-18	N402AP43B6	Washer
MT-19	587E960G1	Housing Ass.
MT-20	247A7400P1	Clamp
MT-21	247A7399P1	Mower Motor Brace Model EA, FA, GA
MT-22	158C9045P1	Baffle Model EA, FA, GA
MT-23	247A7595G1	Foot Guard Asm. Model EA, FA, GA
MT-24	211A3589P1	Grommet
MT-25	247A7552P1	Insert Model EA, FA, GA
MT-26	211A3530P2	Circuit Breaker
MT-27	244A7203P1	Screw
MT-28	243A4600P1	Pin Housing
MT-29	243A4596P1	Socket Housing (Located on Tractor Cable Harness)



\*CIRCUIT BREAKER LOCATION AA MODEL RIDERS ONLY. CIRCUIT BREAKER FOR BA MODEL IS IN THE MOTOR END SHIELD UNDER CAP AND IS NOT SHOWN.

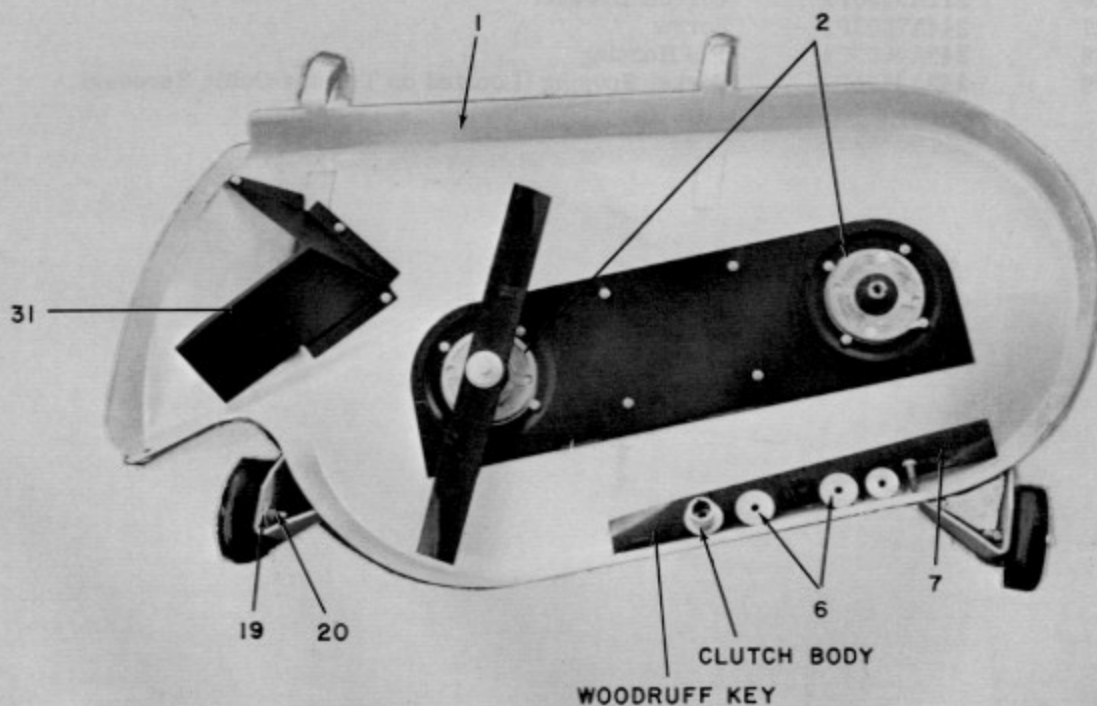
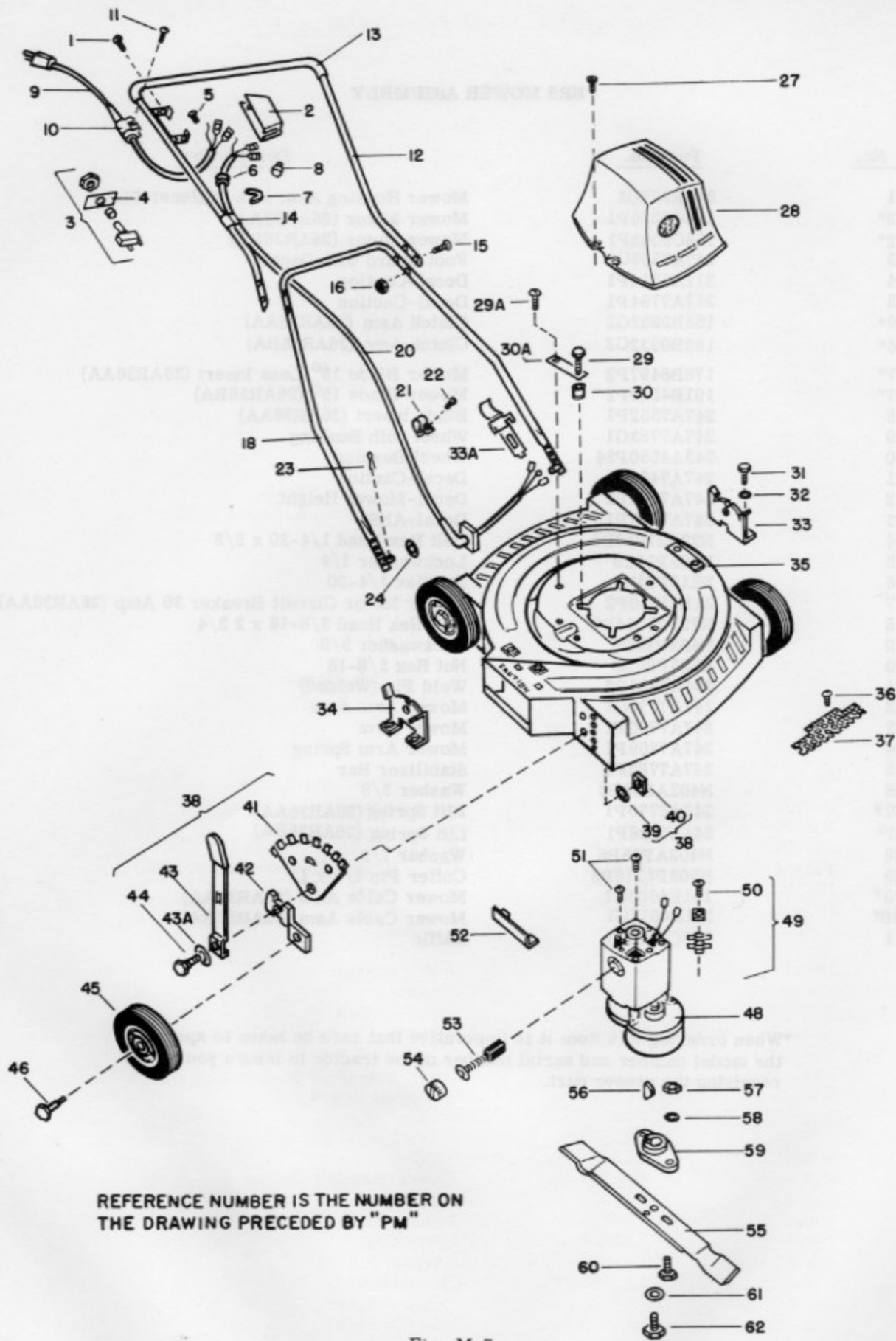

Fig. M-6

## ER8 MOWER ASSEMBLY

<u>Ref. No.</u>	<u>Part No.</u>	<u>Description</u>
1	587E977G1	Mower Housing Asm with Stiffener Plate
2*	158C8086P1	Mower Motor (26AR36AA)
2*	158C9063P1	Mower Motor (26AR36BA)
3	247A7595G1	Foot Guard with Decals
4	211A3514P1	Decal-Caution
5	247A7754P1	Decal-Caution
6*	163B9932G2	Clutch Asm (26AR36AA)
6*	163B9932G3	Clutch Asm (26AR36BA)
7*	178B8497P2	Mower Blade 15 <sup>0</sup> Less Insert (26AR36AA)
7*	191B4540P2	Mower Blade 15 <sup>0</sup> (26AR36BA)
8	247A7552P1	Blade Insert (26AR36AA)
9	247A7783G1	Wheel with Bushing
10	243A4550P34	Wheel Bushing
11	247A7454P1	Decal-Caution
12	247A7450P1	Decal-Mower Height
13	247A7675P1	Decal-ANSI
14	N22P21010B6	Bolt Hex Head 1/4-20 x 5/8
15	N405P11C6	Lockwasher 1/4
16	N210P21B6	Nut Hex 1/4-20
17	211A3530P2	Mower Motor Circuit Breaker 30 Amp (26AR36AA)
18	N22P25044B6	Bolt Hex Head 3/8-16 x 2 3/4
19	N405P13C6	Lockwasher 3/8
20	N203P25B6	Nut Hex 3/8-16
21	244A7233P2	Weld Pin (Welded)
22	247A7774G1	Mower Arm Asm
23	247A7700P1	Mower Arm
24	247A7769P1	Mower Arm Spring
25	247A7782P1	Stabilizer Bar
26	N402AP43B6	Washer 3/8
27*	247A7770P1	Lift Spring (26AR36AA)
27*	244A7328P1	Lift Spring (26AR36BA)
28	N402AP15B6	Washer 1/2
29	N503P1216B6	Cotter Pin 1/8 x 1
30*	191B4603G1	Mower Cable Asm (26AR36AA)
30*	191B4617G1	Mower Cable Asm (26AR36BA)
31	158C9045P1	Baffle

\*When ordering this item it is imperative that care be taken to specify the model number and serial number of the tractor to insure your receiving the proper part.



REFERENCE NUMBER IS THE NUMBER ON THE DRAWING PRECEDED BY "PM"

Fig. M-7

ELEC-TRAK LAWNMOWER - WALK BEHIND

Model PM32B

<u>Ref. No.</u>	<u>Part No.</u>	<u>Description</u>
PM-1	XX2014	Screw (Holds Key 2)
PM-2	XL8419	Switch Housing
PM-3	XL8070	Switch (Less Key 4)
PM-4	XL8083	Escutcheon (For Switch)
PM-5	XX2026	Terminal Screw
PM-6	XX778	Grommet
PM-7	XL8073	Strain Relief
PM-8	XX730	Wire Connector
PM-9	XL8234	Cord Set & Plug
PM-10	XL8063	Clip (Holds 9 to 12)
PM-11	XX2056	Screw (Holds 10 to 12)
PM-12	XL8239	Handle Tube & Sleeve
PM-13	XL8101	Sleeve
PM-14	XL8015	Clip (Holds Key 20 to 12)
PM-15	XL8074	Bolt
PM-16	XX3027	Nut
PM-18	XL8240	Handle Tube (Lower)
PM-20	XL8233	Cord Set (From Switch to Motor)
PM-21	XX782	Cord Clamp
PM-22	XX1005	Screw
PM-23	XX772	Cotter Pin
PM-24	XX5050	Washer
PM-27	XX2006	Screw
PM-28	XL8225	Motor Cover
PM-29	XL8026	Bolt
PM-30	XL8016	Grommet & Washer
PM-31	XX1131	Bolt
PM-32	XX5053	Lockwasher
PM-33	XL8191	Handle Bracket
PM-33A	XL8218	Latch
PM-34	XL8213	Handle Bracket (Chute Side)
PM-35	XL8228	Base Assembly
PM-36	XX2016	Screw
PM-37	XL8146	Screen
PM-38	XL8189	Wheel Height Adjuster (Reversible)
PM-39	XX5080	Lockwasher
PM-40	XX5076	Nut
PM-41	XL8209	Bracket
PM-42	XL8241	Lever
PM-43	XL8211	Wheel Handle
PM-43A	XX5081	Washer
PM-44	XL8242	Shoulder Bolt
PM-45	XL8221	Wheel
PM-46	XL8243	Wheel Bolt
PM-48	XL9000B	Drive Unit (Sold on Exchange Basis Only)
PM-49	XL8010	Terminal Board Kit
PM-50	XX1005	Screw
PM-51	XX1005	Screw
PM-52	XL8103	Baffle
PM-53	XL8031	Carbon Brush & Spring
PM-54	XL8032	Brush Cap
PM-55	XL8138	Blade
PM-56	XL8028	Drive Key
PM-57	XX3038	Adapter Nut
PM-58	XX5064	Lockwasher
PM-59	XL8144	Blade Adapter
PM-60	XX1130	Adapter Bolt
PM-61	XX5068	Lockwasher
PM-62	XL8011	Center Bolt

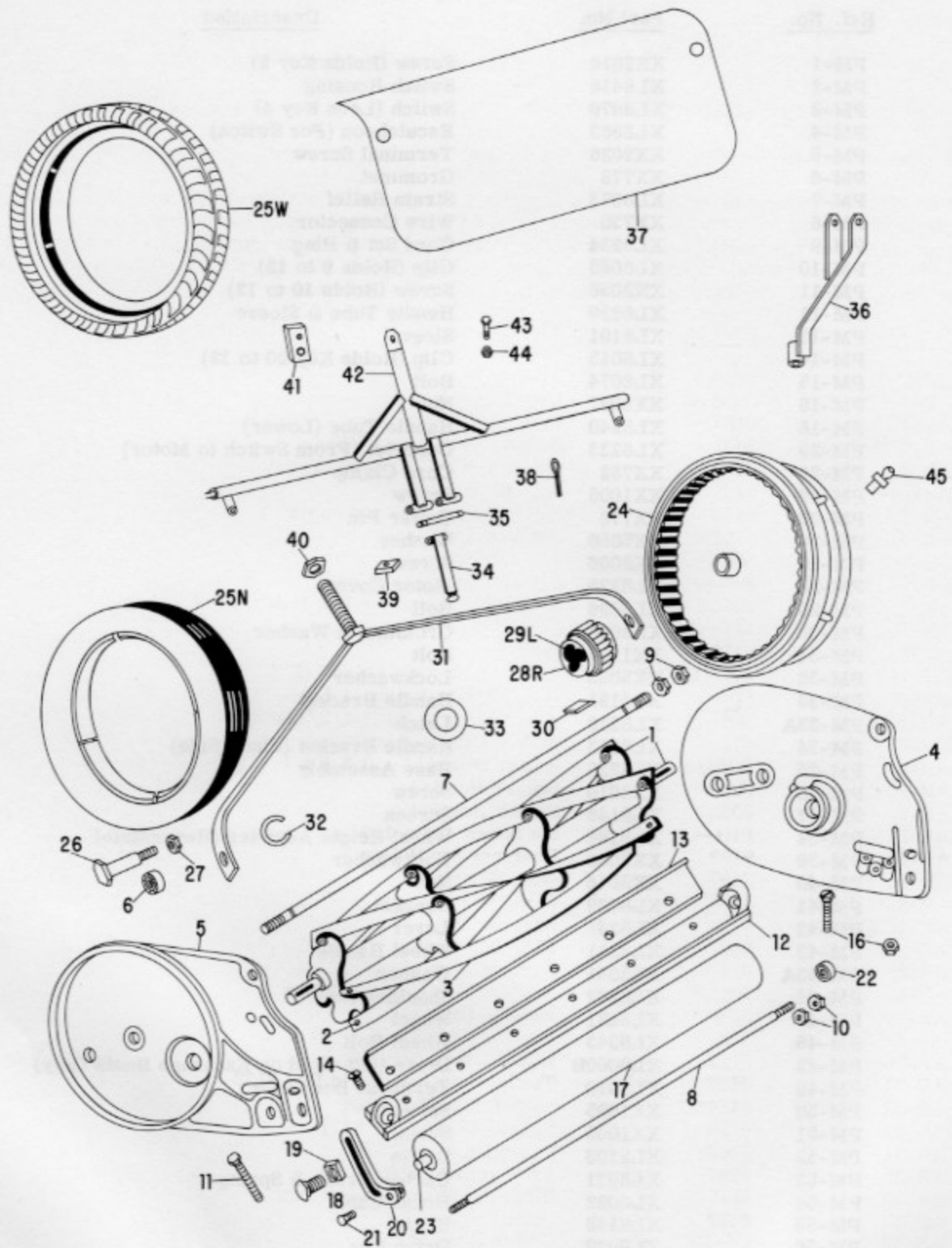

Fig. M-8

FRONT MOUNTED 56" GANG MOWER

Model AR 56

When ordering parts, always include parts number and full description.

Send orders direct to:                   Roxy Bonner, Inc.  
2000 Pioneer Road  
Huntingdon Valley, Pennsylvania 19006

or call: Area Code (215) 675-6869 - Parts

All parts are shipped F.O.B. Huntingdon Valley, Pennsylvania, with terms of net 30 days.

Roxy Bonner warrants its mowers solely against defects in material and workmanship under normal use and service, the obligation under this warranty being limited to making good, at the factory, any parts thereof which shall, within one year after delivery to customer, be returned to company with transportation charges prepaid. This warranty does not apply to any used Roxy mowers or to units repaired or altered in other than company approved shops.

<u>Ref. No.</u>	<u>Part No.</u>	<u>Description</u>
AR-1	6100	Reel Assembly 21"
AR-2	R3-3,5	Reel Blade Rivet
AR-3	6103	Reel Blade
AR-4	6187	Side Plate R - Wide Wheel
AR-5	6188	Side Plate L - Narrow Wheel
AR-6	9400	Side Plate Bearing
AR-7	6128	Tie Rod 5/8, swaged on end
AR-8	6106	Tie Rod 1/2
AR-9	NF-10F	5/8 Jam Nut
AR-10	NF-8F	1/2 Jam Nut
AR-11	B6-12	Side Plate to Cutter Bar Bolt 3/8 x 1 1/4 Hx.
AR-12	6189	Castback
AR-13	6111	Bedknife
AR-14	BK2-12	Bedknife Screws 1/4 x 1/2
AR-15	B05-12	Adj. Screw, Front, 1 1/4
AR-16	B05-14/N5	Adj. Screw, Rear 1 1/2/Locknut 5/16 x 1/2
AR-17	6115	Roller - Less Brg.
AR-18	BJ6-10	Roller Bracket Bolt 3/8 x 1
AR-19	NA-6	Square Nut 3/8
AR-20	6022	Roller Bracket
AR-21	BR4-4	Set Screw 1/4 x 1/2
AR-22	9402	Bearings for Roller
AR-24	6197	Wide Wheel
AR-25W	9408	Wide Tire
AR-25N	9403	Narrow Tire
AR-26	9422	Wide Wheel Stud
AR-26	6119	Narrow Wheel Stud
AR-27	NF-8F	Nut for Wheel Stud 1/2 Hex
AR-28	6123	Pinion, Right
AR-29	6121	Pinion, Left
AR-30	6122	Wheel Pinion Pawl
AR-31	6127	Towing Asm, with Tie Rod 6128
AR-32	9414	Snap Ring, Wh. Shaft
AR-33	6129	Narrow Washer in 6127
AR-34	6140	Extension Arm
AR-35	6066	Extension Arm Pin
AR-36	6515	Hitch for Single Mower Unit
AR-37	6482	Deck
AR-38	C4-10	Cotter Pin 1/8 x 1
AR-39	NA-10	Square Nut 5/8
AR-40	ND-10	Lock Nut 5/8
AR-41	-----	Not Required for Elec-Trak
AR-42	6147	Main Frame
AR-43	B8-24	Hitch Bolt 1/2 x 2 1/2
AR-44	ND8	Lock Nut 1/2
AR-45	9424	Grease Fitting in Wheel

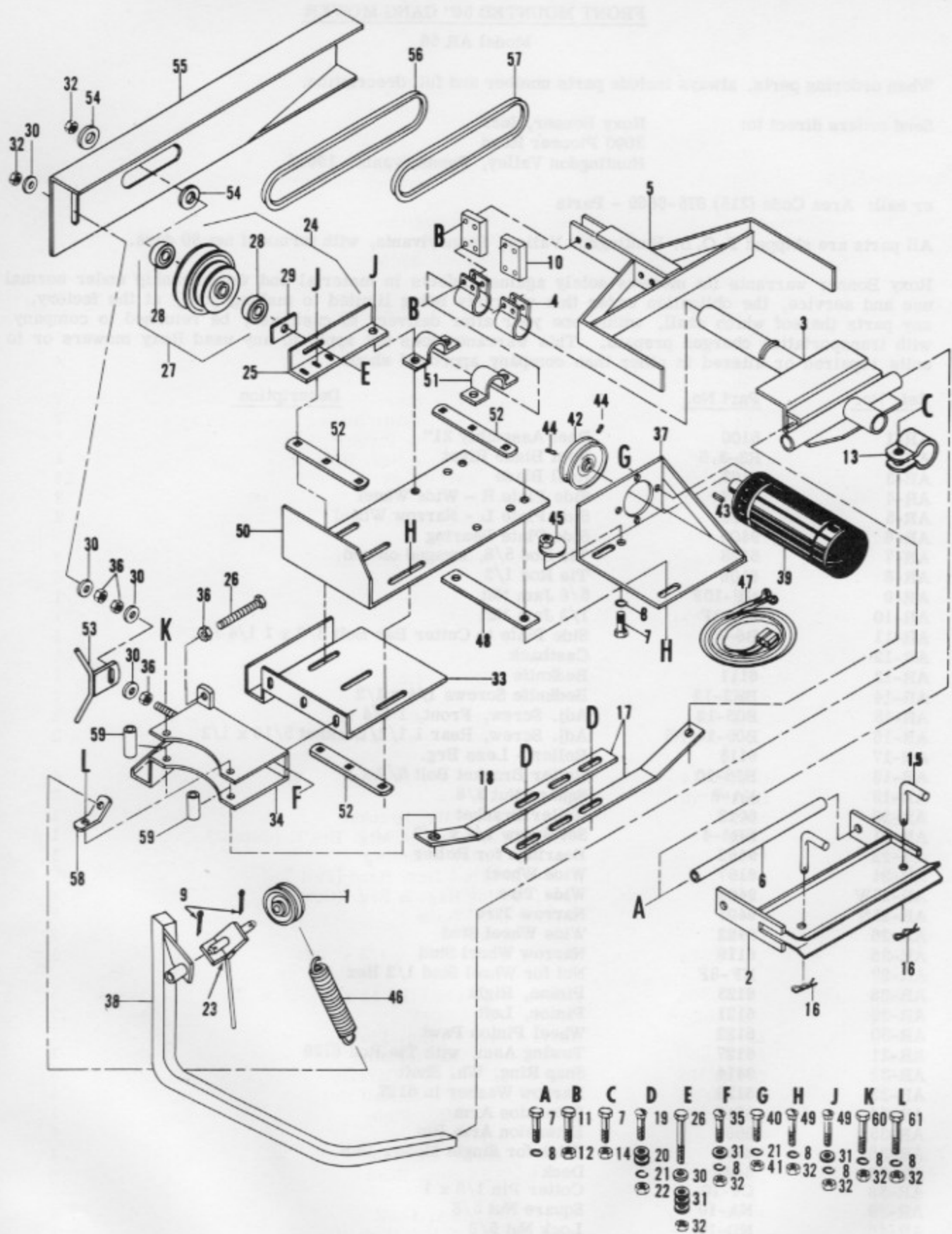

Fig. 11-9

SICKLE BAR MOWER

Model AM 48

When ordering parts, always include part number, model number and full description.

Send orders direct to: Haban Manufacturing Co.  
Mound and Marquette St.  
Racine, Wisconsin 53404

<u>Ref. No.</u>	<u>Part No.</u>	<u>Description</u>	<u>No. Req.</u>
1	4676	Assy. -Pulley & Hub	1
2	8857	Assy. -Rear Mtg. Frame	1
3	8899	Assy. -Pivot Frame	1
4	3976	Clamp-Shock Absorber	1
5	8864	Assy. - Frame Drawbar Hitch	1
6	8868	Shaft-Mtg. Frame to Pivot Frame	1
7	GM180175	Bolt-1/2-13 x 1-1/4 Hex. Head	4
8	GM120384	Washer-1/2 Med. Lock	17
9	GM120123	Pin-Cotter (1/8 x 1-1/4)	2
10	3977	Absorber-Shock (Rubber)	2
11	GM180024	Bolt-1/4-20 x 1-1/4 Hex. Head	8
12	4119	Nut-1/4-20 Hex. Lock	8
13	4304	Sleeve-Front Hanger	1
14	GM9414074	Nut-1/2-13 Lock	1
15	5736	Pin-Locating	2
16	3430	Pin-Hair Cotter	2
17	8975	Assy. -Stabilizer Strap	1
18	8894	Strap-Stabilizer	2
19	GM126358	Bolt-Carriage (3/16-18 x 1)	2
20	GM120386	Washer-Flat (5/16 x 3/4 x .065)	2
21	GM120214	Washer-5/16 Med. Lock	4
22	GM120376	Nut-5/16-18 Hex	2
23	5663	Assy. -Pulley Mtg. Bracket	1
24	7748	Assy. -Pulley Hsg. & Mtg. Brk't. (Comp.)	1
25	6824	Bracket-Pulley Mounting	1
26	5790	Bolt-1/2-13 x 4 Hex. Head (Full Thd.)	2
27	6825	Assy. -Pulley Hsg. & Brg. (Comp)	1
28	5337	Bearing-1/2" Bore	2
29	8979	Assy. -Spacer	1
30	GM120389	Washer-Flat (1/2 x 1-1/4 x .083)	3
31	GM120396	Washer-(1/2 Flat) (17/32 x 1-1/16 x .095)	8
32	GM-120378	Nut-1/2-13 Lt. Hex	17
33	8974	Assy. -Carriage Adj. Plate	1
34	8977	Assy. -Breakaway Housing	1
35	GM126485	Bolt-1/2-13 x 1-1/4 Carriage	3
36	GM120238	Nut-(Anchor) 1/2-13 Half Hex	4
37	8883	Assy. -Motor Mtg. Plate	1
38	6604	Assy. -Carrier Bar	1
39	8886	Motor-(General Electric)	1
40	GM180079	Bolt-5/16 x 1 Hex. Head	2
41	GM9413447	Nut-5/16-18 Hex. Lock	2
42	8887	Assy. -Pulley & Hub (Hub in)	1
43	3259	Key-3/16 Sq. x 1"	1
44	GM142671	Screw-Set (5/16-18 x 1/2 Sq. Hd. Cup Pt.)	2



SICKLE BAR MOWER (Continued)

Model AM 48

<u>Ref. No.</u>	<u>Part No.</u>	<u>Description</u>	<u>No. Req.</u>
45	8888	Assy. -Adjust Disc	1
46	3434	Spring-Lift & Transport	1
47	8890	Cord Assy	1
48	8891	Plate-Spacer	1
49	GM120917	Bolt-1/2-13 x 1-1/2 Carriage	9
50	8892	Plate-Pivot Bracket	1
51	3984	Bracket-Mounting	2
52	8243	Strap-Locator	3
53	7328	Belt Retainer	1
54	6979	Washer-(Flat) (17/32 x 2-3/8 x 16 Ga.)	4
55	8893	Guard-V-Belt	1
56	8104	V-Belt (Motor to Idler)	1
57	4577	V-Belt (Idler to Basic Sickle)	1
58	6073	Anchor-Spring	1
59	3554	Spacer-Breakaway Housing	2
60	GM180190	Bolt-1/2-13 x 3 Hex. Head	1
61	GM180192	Bolt-1/2-13 x 3-1/2 Hex. Head	1

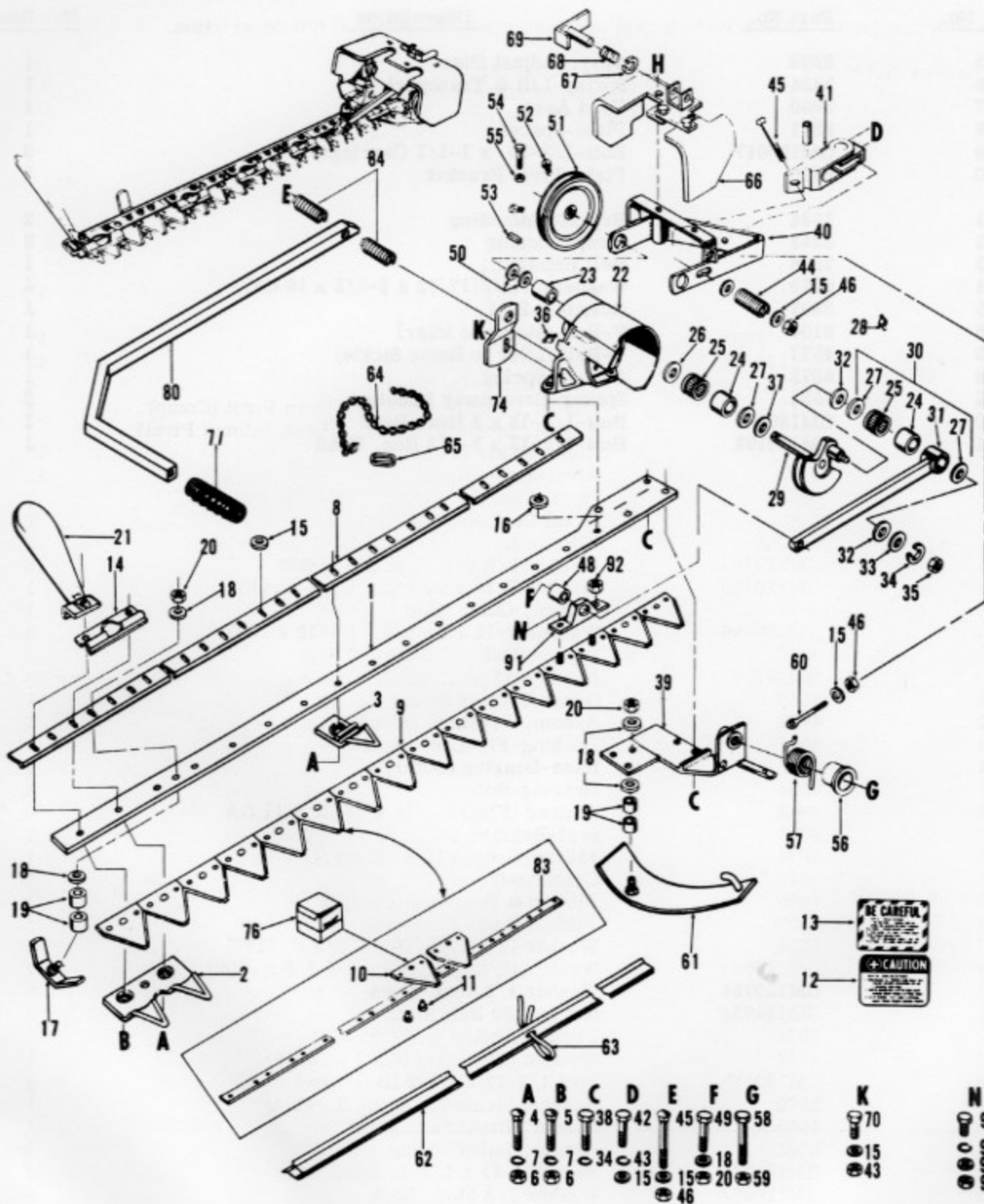

Fig. M-10

SICKLE BAR MOWER

Model AM 48

When ordering parts, always include part number, model number and full description.

Send orders direct to:

Haban Manufacturing Co.  
Mound and Marquette St.  
Racine & Wisconsin 53404

<u>Ref. No.</u>	<u>Part No.</u>	<u>Description</u>	<u>No. Req.</u>
1	3592	Sickle Bar	1
2	6732	Finger-Shear	8
3	7188	Shear Finger	1
4	GM126452	Bolt 7/16-14 x 1 1/2 Carr.	16
5	GM120916	Bolt 7/16-14 x 1 3/4 Carr.	1
6	GM271501	Nut-7/16-14 Lt. Hex.	17
7	GM120383	Washer 7/16 Med. Lock	17
8	3597A	Plate-Universal Wear	4
9	3622	Assem., Sickle Knife & Pitman Pivot (Comp)	1
9A	6612	Assem. Sickle Knife Only (Less Pitman Pivot)	1
10	3928	Knife-Sickle (3-Hole)	16
11	6066	Rivet-Sickle Knife	32
12	6625	Decal Caution	1
13	S 820	Decal Be Careful	1
14	3598 A	Clip Knife	5
15	GM120388	Washer 3/8 Flat 7/16 x 1 x .083	18
16	GM120389	Washer 7/16 Flat 1/2 x 1 1/4 x .083	1
17	5571	Assem. Outer Shoe	1
18	GM120396	Washer 7/16 Flat 1/2 x 1 1/16 x .095	6
19	3346	Spacer (Outer Shoe) 1/2 Long	4
20	GM9414074	Nut 1/2-13 Hex. Lock	3
21	4648	Grass Divider Board	1
22	4707	Assem. Flywheel Housing	1
23	3034	Bushing-Flywheel Housing	1
24	4683	Race-Bearing (Outer)	2
25	4684	Bearing-Roller	2
26	4653	Washer (Flat) 1 5/16 x 15/16 x 11 GA	1
27	4656	Seal-Bearing Oil	3
28	5074	Fitting-Grease (1/4-28 Str.)	1
29	4641	Crankshaft	1
30	4685	Pitman & Bearings (Comp.)	1
31	4629	Pitman (Less Bearings)	1
32	4654	Washer (Flat) (15/16 x 1 1/2 x .0299)	2
33	GM120390	Washer (1/2 Flat) (9/16 x 1 3/8 x .109)	1
34	GM120384	Washer 1/2 Med. Lock	5
35	GM124934	Nut 1/2-20 Half Hex.	1
36	5074	Fitting-Grease (1/4-28 Str.)	1
37	4719	Washer (Flat) (15/16 x 2 x .0299)	1
38	GM180177	Bolt 1/2-13 x 1 1/2 Hex. Head	3
39	3570	Assem. Sickle Mounting Bracket	1
40	3555 A	Assem. Breakaway Pivot	1
41	5602	Assem. Latch (Comp.)	1
42	GM180122	Bolt-3/8-16 x 1 Hex. Head	2
43	GM120382	Washer 3/8 Med. Lock	5
44	3411	Spring-Latch & Lift Strap	1
45	GM126705	Bolt 3/8-16 x 3 Carriage	2
46	GM9413534	Nut 3/8-16 Hex. Lock	3

SICKLE BAR MOWER (Continued)

Model AM 48

<u>Ref. No.</u>	<u>Part No.</u>	<u>Description</u>	<u>No. Req.</u>
47			
48	1094	Bushing-Pitman Pivot	1
49	GM180179	Bolt 1/2-13 x 1 3/4 Hex. Head	1
50	3396	Washer (49/64 x 1 1/2 x .0598)	2
51	4638	Pulley (Crankshaft)	1
52	GM142671	Screw-Set (5/16-18 x 1/2 Sq. Head)	2
53	4585	Key-Pulley (3/16 Sq. x 1 1/2)	1
54	GM180042	Bolt 1/4-20 x 1 3/4 Hex. Head	1
55	4119	Nut 1/4-20 Hex. Lock	1
56	4645	Retainer-Torsion Spring	1
57	4655	Spring-Torsion	1
58	GM271724	Bolt 5/8-11 x 2 1/4 Hex. Head	1
59	GM124847	Nut 5/8-11 Half Hex.	1
60	3058	Eye Bolt-Spring	1
61	3604 A	Inner Skid Shoe	1
62	4690	Guard-Sickle Bar	1
63	4686	Guard Strap	1
64	4716	Chain-Transport	1
65	3436	Anchor-Chain	1
66	7323	Assem. Housing Stop & Quick Pin	1
67	6795	Snap Ring	1
68	5681	Spring-Coupler	1
69	6791	Assem. Quick Pin	1
70	GM180120	Bolt-3/8-16 x 3/4 Hex. Head	3
71			
72			
73			
74	6850	Vertical Position Stop	1
75			
76	8163	Rivets-16 oz. Box #6066 Rivets (Repairs)	1
77	3339	Grip-Handle	1
78	GM180175	Bolt 1/2-13 x 1 1/4 Hex. Head	1
79	GM120378	Nut 1/2-13 Lt. Hex.	1
80	42014	Handle-Lift	1
80			
81			1
82			1
83	4631	Back-Sickle Knife	16
84	3411	Spring	1
85			
86			
87			
88			
89			
90			
91	8224	Pitman Pivot Kit Consisting of:	
	FOR LATE	{ 1 6614 Pivot	
92	PRODUCTION	{ 2 6617 Cone Nuts	

SICKLE BAR MOWER (Continued)

Model AM 48

<u>Ref. No.</u>	<u>Part No.</u>	<u>Description</u>	<u>No. Req.</u>
93	FOR EARLY PRODUCTION	{ 2 8223 Spacer Nuts 2 GM180018 Bolt 5/8 Hex. Hd. 2 GM120380 Washer Lock 1/4 2 446188 Washer Flat 1/4	
94			
95			
96			

MOWER MODEL	PART				
	Motor	Blade	Clutch Asm.	Shaft Key	Circuit Breaker
26AH36AA BA, CA, DA EA, FA, GA	155C8086P1 247A7673P4 (Reconditioned)	High Discharge: AP26 Std. Discharge: AP27	163B9932G2	211A3565P1	211A3530P2
26AA42AA, BA, DA, FA HA, JA	211A3435G1 247A7671P1 (Reconditioned)	AP25	163B9932G1	211A3565P1	211A3530P1
26AA42CA, EA, GA	Original: 541C971P1 247A7673P1 (Reconditioned)  Replacement: 158C9017P1 247A7673P3 (Reconditioned)	AP25	163B9932G1	211A3565P1	247A7390P1
26AA42LA, NA, PA	158C9017P1 247A7673P3 (Reconditioned)	AP25	163B9932G1	211A3565P1	247A7390P1
26AA42MA (Heavy Duty)	158C9011P1 247A7673P5 (Reconditioned)	AP25	163B9932G1	211A3565P1	247A7390P3

MISCELLANEOUS  
AND HARDWARE

MISCELLANEOUS & HARDWARE

E20, E15, E12S, E12, E12M

<u>Ref. No.</u>	<u>Part No.</u>	<u>Description</u>
Z-1	541C922P1	Instruction Decal (Located Under Hood)
Z-2	211A3599P1	Paint (Spray Yellow)
Z-2a	243A4679P1	Paint (Yellow - 1 Pint) - AP50
Z-3	243A4640P1	Front Wheel Bearing
Z-4	243A4680P1	Grease Tube (2 oz.)
Z-5	243A4564P5	Plug (P-1)
Z-6	243A4564P4	Plug (P-2)
Z-7	243A4564P3	Plug (P-4)
Z-8	243A4568P4	Jack (J-1)
Z-9	243A4568P5	Jack (J-2)
Z-10	243A4568P3	Jack (J-4)
Z-11	211A3594G2	Terminal Kit
Z-12	N3400P606	Woodruff Key (Brake) (3/16" x 3/4") or #9
Z-13	N3400P809	Woodruff Key (Rear Axle)(1/4" x 1 1/8") or #18
Z-14	N3402P6032	Key (Drive Motor) (3/16" x 1")
Z-15	N922P75C6	Snap Ring (Front Axle) (3/4")
Z-16	243A4587P1	Thrust Washer (Front Axle)
Z-17	N533P1316	Roll Pin (Front Axle) (1/8" x 1")
Z-18	N533P1916	Roll Pin 3/16 x 1" (Lift Actuator)
Z-19	N533P2516	Spring Dowel Pin (Steering Wheel) (1/4" x 1")
Z-20	N533P1618	5/32 x 1 1/8 Spring Dowel Pin (Brake Asm)
Z-21	211A3584P1	Curved Washer (Parking Brake Lever)
Z-22	243A4613P1	Shim Washer (Steering)
Z-23	N402AP18B6	Plain Washer (Steering) (3/4")
Z-24	N402P45B6	Washer (For Front Lift) (1/2")
Z-25	211A3488P1	Push Nut (Spring Clip, Brake Rod)
Z-26	N264P21B6	1/4-20 Locking Nut, Hex (Used on Brake Shoulder Screw)
Z-27	211A3562P1	Speed Nut (On Charger Screen)
Z-28	N503P1220B6	Cotter Pin (Steering) (1/8" x 1 1/4")
Z-29	N503P1216	Cotter Pin (Front Roller, Mower) (1/8" x 1")
Z-30	211A3505P2	Clevis Pin (Frame)
Z-31	243A4810P1	Battery Cap Wrench
Z-32	163B9887G1	Battery Clamp Assembly
Z-33	211A3439G1	Battery Clamp, Right
Z-34	211A3439G2	Battery Clamp, Left
Z-35	211A3440G1	Battery "U" Clamp
Z-36	211A3442P1	Battery Clamp Bar
Z-37	243A4543P3	Hair Pin Cotter
Z-38	243A4543P1	Hair Pin Cotter
Z-39	243A4539P3	Mate-N-Lok (60620-1)
Z-40	243A4552P2	Mate-N-Lok (60619-1)
Z-41	243A4541P3	Ring, Awg. 12-10, 1/4 Stud (31172)
Z-42	243A4541P4	Ring, Awg. 8, 1/4 Stud (33461)
Z-43	243A4541P5	Ring, Awg. 6, 1/4 Stud (321598)
Z-44	243A4541P6	Ring, Awg. 12-10, 5/16 Stud (31827)
Z-45	243A4541P7	Ring, Awg. 8, 5/16 Stud (31808)
Z-46	243A4541P8	Ring, Awg. 16-14, #10 Stud (34123)
Z-47	243A4541P9	Ring, Awg. 16-14, 1/4 Stud (31256)
Z-48	243A4541P10	Ring, Awg. 16-14, 5/16 Stud (31257)
Z-49	243A4541P11	Ring, Awg. 22-16, 5/16 Stud (31252)
Z-50	243A4541P1	Ring, Awg. 12-10, #10 Stud (31805)
Z-51	243A4822P1	Receptacle, Awg. 16-14 (60628-1)
Z-52	243A4822P2	Receptacle, Awg. 16-12, 1/4 (42844-1)
Z-53	243A4553P1	Receptacle, Awg. 20-16, #18, (60972-2)
Z-54	243A4566P1	Common Tab (60843-1)
Z-55	243A4660P1	Shur Plug Receptacle (61075-2)
Z-56	243A4567P1	Splice

MISCELLANEOUS & HARDWARE

E8M, E10M

<u>Ref. No.</u>	<u>Part No.</u>	<u>Description</u>
Z-57	211A3505P1	Clevis Pin (Seat Housing Hinges and Line Asm)
Z-58	N503P1212B6	Cotter Pin (For Z-57; 1/8 x 3/4)
Z-59	211A3505P14	Clevis Pin (Brake and Clutch Rod)
Z-60	211A3505P17	Clevis Pin (Parking Brake)
Z-61	N503P916B6	Cotter Pin (For Z-59 and Z-60; 3/32 x 1)
Z-62	244A7221P1	Clevis Pin (Rear Wheel)
Z-63	N503P1516B6	Cotter Pin (For Z-62; 5/32 x 1)
Z-64	155C8167P1	Instruction Decal (Located Under Hood)
Z-65	211A3589P4	Grommet (Bottom of Tractor)
Z-66	244A7327P1	Sleeve (Under Steering Wheel)
Z-67	244A7438P1	Cable Clip
Z-68	243A4505P1	Hydrometer
Z-69	243A4507P1	Multimeter
Z-70	243A4508P1	Battery Service Kit
Z-71	243A4510P1	Crimping Tool
Z-72	243A4510P2	Crimping Tool
Z-73	243A4513P1	Battery Lifting Strap



TABLE OF CONTENTS

FIGURE

TITLE

S-1

Large Frame Steering

S-2

Small Frame Steering

72

76

74

710

711

715

77

78

79

712

713

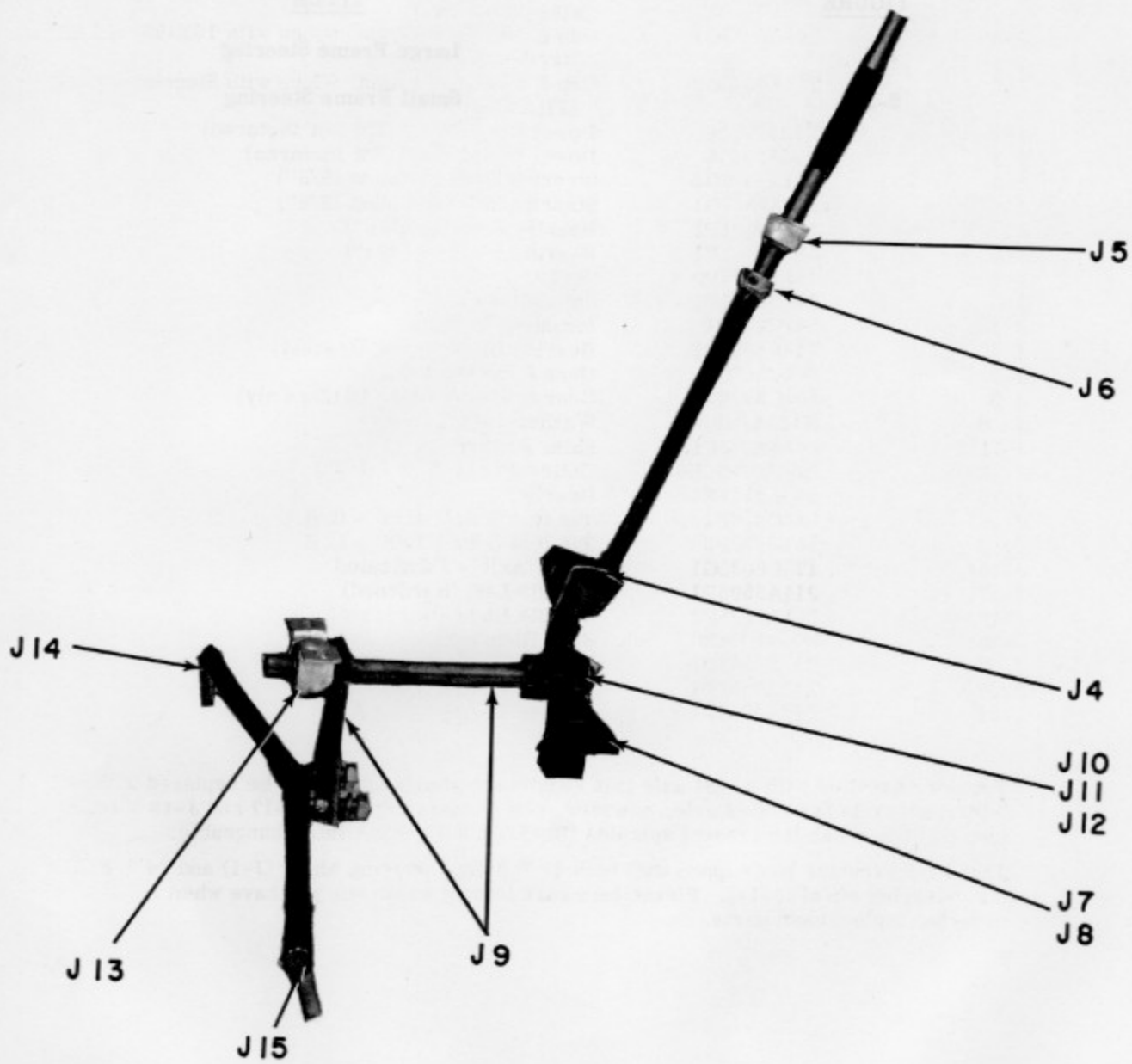

Fig. S-1

LARGE FRAME STEERING

<u>Ref. No.</u>	<u>Part No.</u>	<u>Description</u>
J-1	423D255P1	Steering Wheel (E20, E16, E15, E14)
J-1+	163B9843P1	Steering Wheel (E15, E12s, E12)
J-1	127D8023P1	Steering Wheel (E12M)
J-2	243A4828G1	Cap & Monogram Asm. (Goes with 423D255P1 Steering Wheel)
J-2	243A4853G1	Cap & Monogram Asm. (Goes with 163B9843P1 Steering Wheel)
J-2	243A4828G2	Cap & Monogram Asm. (Goes with Steering Wheel 127D8023P1)
J-3	N533P2520	Dowel Pin (1/4 x 1 1/4 Not Pictured)
J-3	N533P2516	Dowel Pin (1/4 x 1 Not Pictured)
J-4	211A3416G2	Steering Shaft & Pinion (5/8")
J-4	211A3416G1	Steering Shaft & Pinion (3/4")
J-5	211A3101P2	Bearing Steering (5/8")
J-5	211A3101P1	Bearing Steering (3/4")
J-6	243A4547P2	Set Collar (5/8")
J-6	243A4547P1	Set Collar (3/4")
J-7	541C902P1	Mounting Bracket
J-8	243A4590P1	Bearing (In Mounting Bracket)
J-9	542C898G1	Gear & Sector Asm.
J-9	542C898G3	Gear & Sector Asm. (E12M Only)
J-10	N402AP18B6	Washer (3/4")
J-11	243A4613P1	Shim Washer
J-12	N503P1220B6	Cotter Pin (1/8" x 1 1/4")
J-13	243A4561P1	Bearing
J-14	541C950P1	Tie Rod & Ball Joint - R.H.
J-15	541C950P2	Tie Rod & Ball Joint - L.H.
J-16#	178B8032G1	Front Axle - Fabricated
J-17#	211A3595P1	Spindle Left (Hardened)
J-18#	211A3595P2	Spindle Right (Hardened)
J-19	N922P75C6	Snap Ring (3/4")
J-20	243A4587P1	Thrust Washer
J-21	243A4867P1	Grease Fitting (Fab Axle)
J-21	243A4609P1	Grease Fitting (Cast Axle)

# Tractors supplied with a cast axle that requires replacement should be replaced with an interchangeable fabricated axle, however, new hardened spindles J-17 and J-18 should also be ordered as the present spindles (Unhardened) are not interchangeable.

+ This model tractor is equipped with both 12 7/8 dia. steering wheel (J-1) and 14 7/8 dia. steering wheel (J-1+). Please take care to note which one you have when ordering replacement parts.

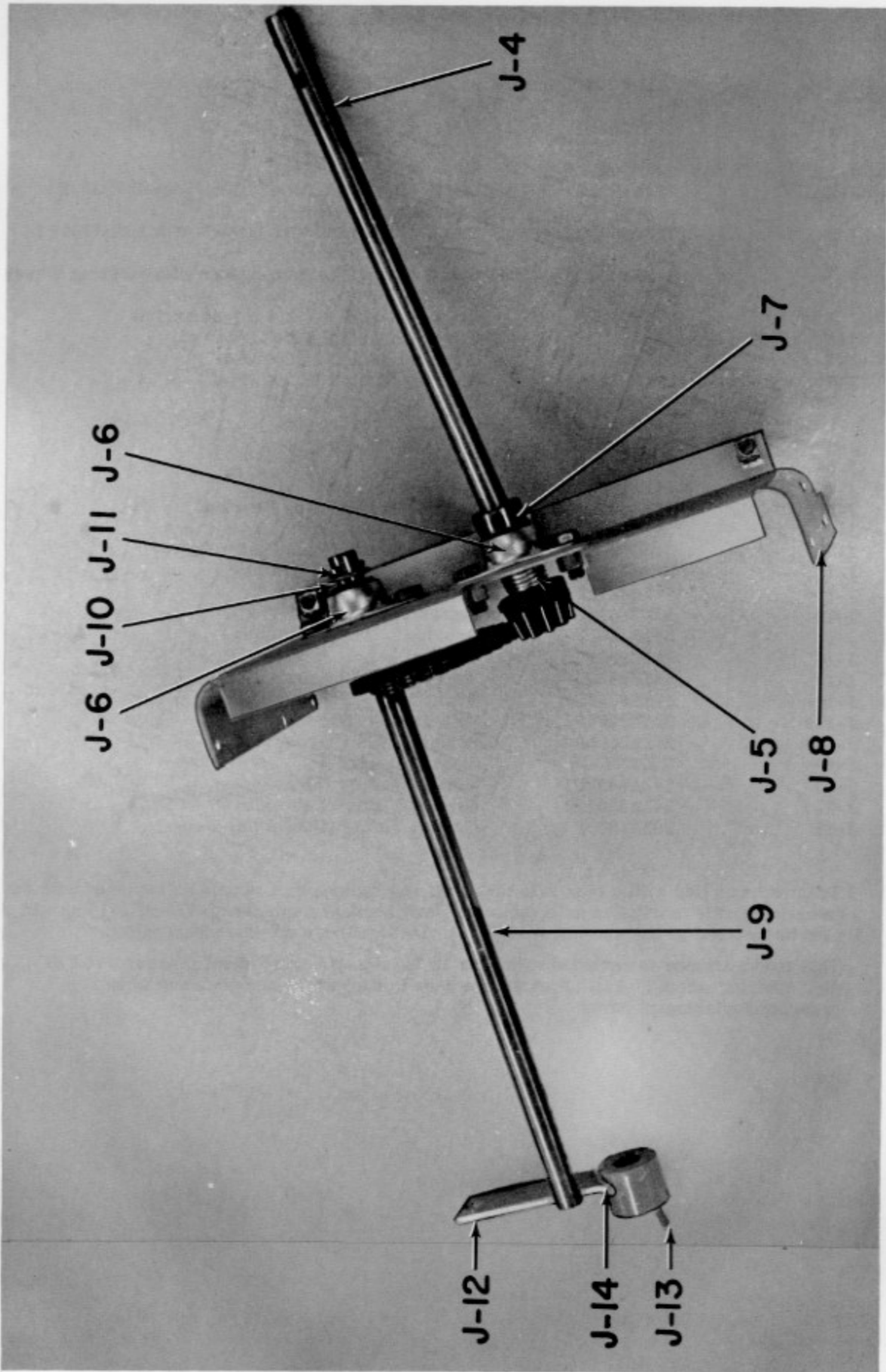

Fig. S-2

SMALL FRAME STEERING

<u>Ref. No.</u>	<u>Part No.</u>	<u>Description</u>
J-1	127D8023P1	Steering Wheel (Not Pictured)
J-2	243A4828G2	Cap and Monogram Asm. (Not Pictured)
J-3	N533P2520	Spring Dowel Pin, Steering Wheel (1/4 x 1 1/4 - Not Pictured)
J-4	244A7176G2	Shaft and Pinion Assembly
J-5	211A3577P16	Spring
J-6	211A3101P2	Bearing
J-7	243A4547P2	Set Collar
J-8	155C8141P1	Steering Shaft Support
J-9	244A7175G1	Shaft and Segment Assembly (All Models Except E10DA)
J-9	247A7372G1	Shaft and Segment Assembly (E10DA Only)
J-10	244A7322P1	Washer
J-11	N533P1616	Spring Dowel Pin
J-12	244A7183G1	Steering Arm Asm. (All Model Except E10DA)
J-12	178B8402G1	Steering Arm Asm. (E10DA Only)
J-13	N3400P405	Key (1/8 x 5/8 Woodruff) (Except E10DA)
J-13	N533P2524	Spring Dowel Pin (E10DA Only)
J-14	N72P2108B6	Set Screw (1/4-20 x 1/2) (Not Used on E10DA Model)
J-15	243A4550P17	Spacer (Not Shown, Located on Top of Shaft J-9)

UNDERCARRIAGE, L.F.

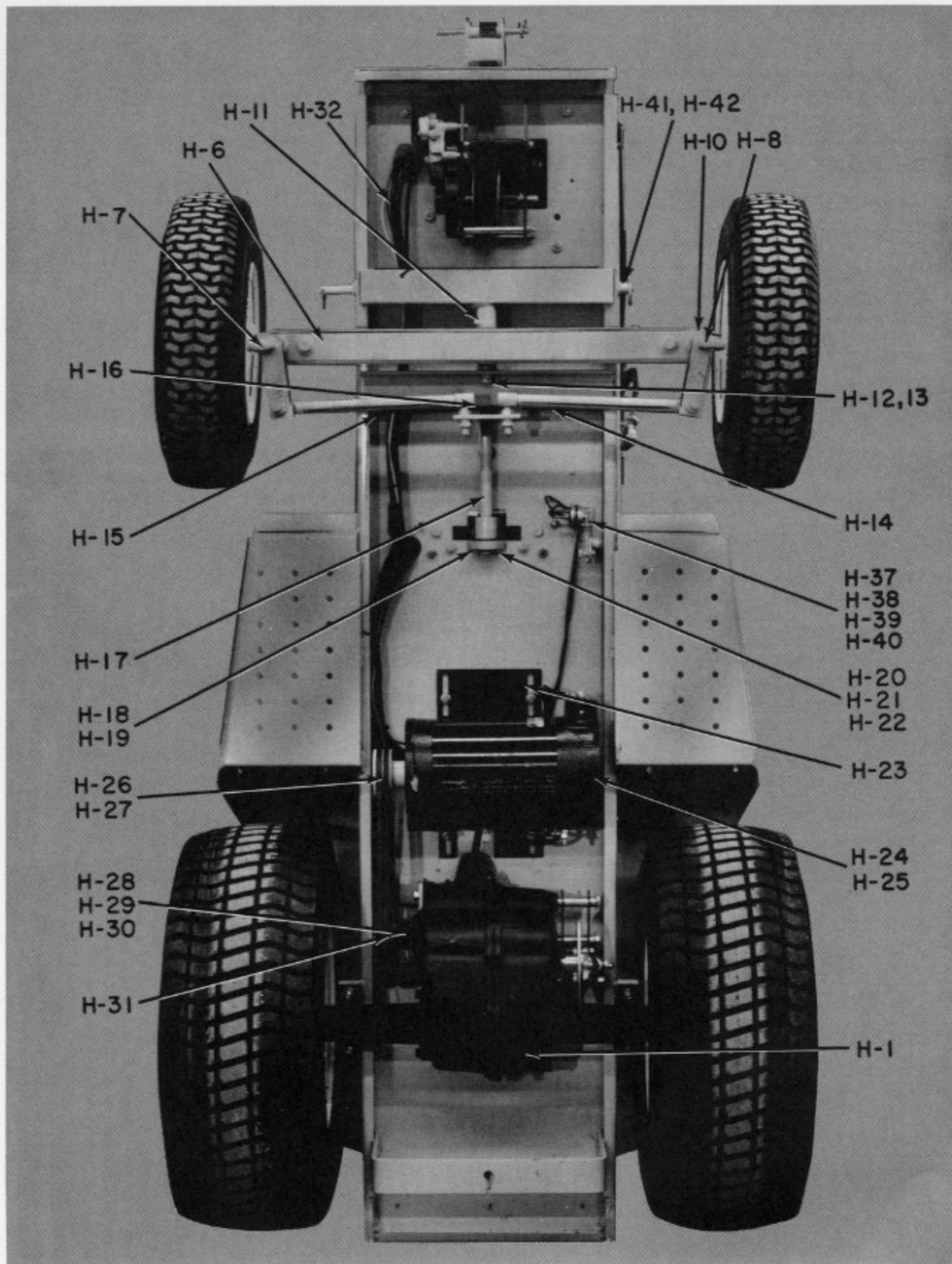

Fig. U-1

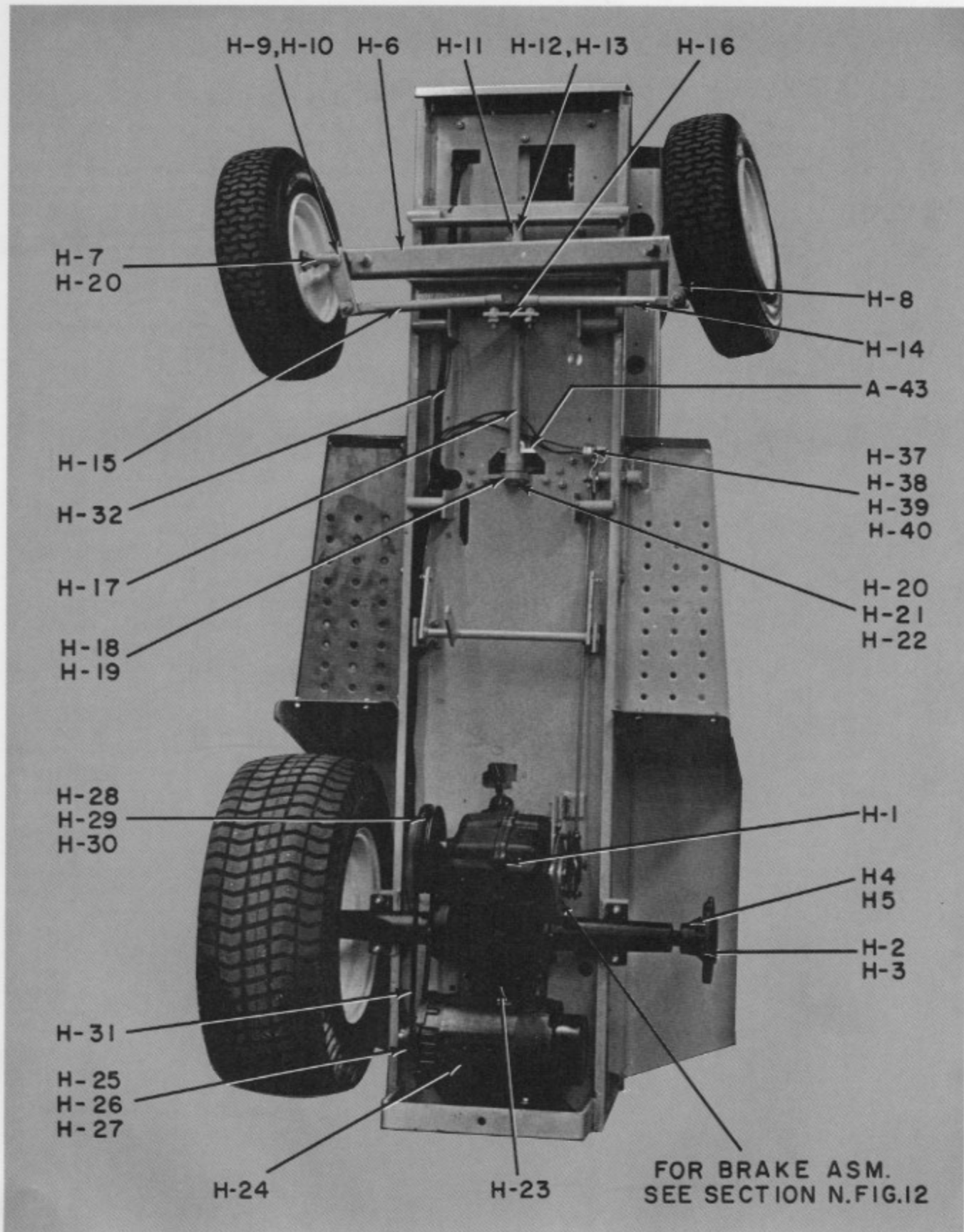

Fig. U-2

UNDERCARRIAGE COMPONENTS

<u>Ref. No.</u>	<u>Part No.</u>	<u>Description</u>
H-1	422D818P1	Transaxle (E20, E16, E15, E14, E12)(Peerless 2318)
H-1	127D8001P1	Transaxle (E12M Only) (Peerless 1716)
H-2	211A3107P1	Hub, Painted (See E12M Detail)
H-3	N3400P809	Key (1/4 x 1/8) (See E12M for Detail)
H-4	N72P2316C6	Set Screw (5/16-18 x 1) (See E12M for Detail)
H-5	N213P23B6	Jam Nut (5/16-18) (See E12M for Detail)
H-6*	541C685P1	Front Axle, Cast (No Longer Available)
H-6*	178B8032G1	Front Axle, Fabricated
H-7	178B8371G1	Spindle, Right (Hardened) - Uses Part No. 9 and 44
H-8	178B8282G1	Spindle, Left (Hardened) - Uses Part No. 9 and 44
H-9	N922P75C6	Snap Ring (Located on Spindle) - (3/4")
H-10	243A4587P1	Thrust Washer (Located on Spindle)
H-11	243A4609P1	Grease Fitting (Cast Axle)
H-11	243A4867P1	Grease Fitting (Fab Axle)
H-12	244A7416P1	Pivot Pin
H-13	N533P1316	Roll Pin (1/8 x 1)
H-13	N922P62C6	Snap Ring (Used on Pivot Pin) - (5/8")
H-14	541C950P1	Tie Rod and Ball Joint (R.H.)
H-15	541C950P2	Tie Rod and Ball Joint (L.H.)
H-16	243A4561P1	Bearing
H-17	542C898G1	Gear and Sector Assembly (E20, E16, E15, E14, E12)
H-17	542C898G3	Gear and Sector Assembly (E12M Only)
H-18	541C902P1	Mounting Bracket
H-19	243A4590P1	Bearing (In Mounting Bracket)
H-20	N402AP18B6	Plain Washer - (3/4")
H-21	243A4613P1	Shim Washer
H-22	N503P1220B6	Cotter Pin - (1/8 x 1 1/4")
H-23	541C915P2	Motor Plate (E20)
H-23	541C915P1	Motor Plate (E16, E15, E14RC, E14RD, E14RH, E12AA, E12BA, E12CA, E12DA, E12HA)
H-23	155C8083P1	Motor Plate (E12M Only)
H-23	155C8151P1	Motor Plate (E14AA, E14RJ, E12JA, E12JD)
H-24	163B9862P1	Drive Motor (E16, E15, E12s) (New) - 247A7667P1 (Factory Rebuilt)
H-24	163B9996P1	Drive Motor (E20) (New) - 247A7670P1 (Factory Rebuilt)
H-24	178B8034P1	Drive Motor (E12, E12M, Except E12JA) (New) - 247A7751P1 (Factory Rebuilt)
H-24	163B9991P1	Drive Motor (E14AA, E14RJ, E12JA, E12JD) (New) - 247A7750P1 (Factory Rebuilt)
H-25	211A3244P1	Drive Motor Circuit Breaker (E16, E15, E12s)
H-25	243A4859P1	Drive Motor Circuit Breaker (E20)
H-26	243A4785P1	Drive Motor Pulley (E20)
H-26	211A3254P1	Drive Motor Pulley (E16, E15)
H-26	243A4675P5	Drive Motor Pulley (E14, E12, E12M)
H-26	243A4675P2	Drive Motor Pulley (E12s)
H-27	N70P2312B6	Set Screw (5/16-18 x 3/4)
H-27	N22P2310B6	Set Screw (5/16-18 x 5/8)
H-28	163B9877P1	Transaxle Pulley
H-29	N70P2312B6	Set Screw (5/16-18 x 3/4)
H-30	N3400P606	Key (3/16 x 3/4 Woodruff)
H-31	211A3226P4	Drive Belt (Pair) (E20, E16, E15)
H-31	211A3226P2	Drive Belt (E12s)
H-31	211A3226P5	Drive Belt (E14, E12)
H-31	211A3226P10	Drive Belt (E12M)
H-32		Undercarriage Harness
H-32	423D215G1	Undercarriage Harness (E15AA)
H-32	423D234G1	Undercarriage Harness (E15BA, CA, CB, DA)



UNDERCARRIAGE COMPONENTS (Cont'd)

<u>Ref. No.</u>	<u>Part No.</u>	<u>Description</u>
H-32	127D8011G1	Undercarriage Harness (E15EA, FA, GA)
H-32	127D8097G1	Undercarriage Harness (E16AA, RA, RB, RD, E15HA, JA)
H-32	423D275G1	Undercarriage Harness (E20AA, E20BA, E20CA, CB, CC)
H-32	127D8105G1	Undercarriage Harness (E20DA)
H-32	127D8099G1	Undercarriage Harness (E20EA, EC, ED, FA, RA)
H-32	423D234G2	Undercarriage Harness (E12AA, BA)
H-32	423D 228G1	Undercarriage Harness (E12CA, E12DA, E14RC, E14RD)
H-32	127D8074G1	Undercarriage Harness (E12HA, E14RH)
H-32	127D8100G1	Undercarriage Harness (E14AA, RJ, E12JA, JD)
H-32	127D8003G1	Undercarriage Harness (E12EA)
H-33	243A4540P2	Cable Tie
H-37	211A3481P1	Brake Switch (E20, E16, E15, E14, E12)
H-37	244A7131P1	Brake Switch (E12M)
H-38	243A4585P1	Mounting Base (Brake Switch)
H-39	211A3504P1	Shoulder Screw (E20, E16, E15, E14, E12)
H-39	N657P21024B6	Carriage Bolt (1/4-20 x 1 1/2) E12M
H-40	N264P21B6	Locknut, Hex (1/4"-20)
H-41	211A3505P2	Clevis Pin (E20, E16, E15, E14, E12)
H-41	243A4550P1	Spacer (E12M)
H-42	211A3256P2	Hairpin Cotter (E20, E16, E15, E14, E12)
H-42	244D7177P1	Shim, Motor Plate (E12M)
H-43	244A7163P1	Cable Clip (All Models)
H-44	N402AP18B6	Washer (Spindle) (3/4")
H-45	N3402P6036	Key, Drive Motor (3/16 x 1 1/8)
H-46	N22P25028B6	Self-Lock Cap Screw - For Old-type Spindles (3/8-16 x 1 3/4")

\* Tractors supplied with a cast axle that requires replacement should be replaced with an interchangeable fabricated axle, however, new hardened spindles H-7 and H-8 should also be ordered as the present spindles (Unhardened) are not interchangeable.

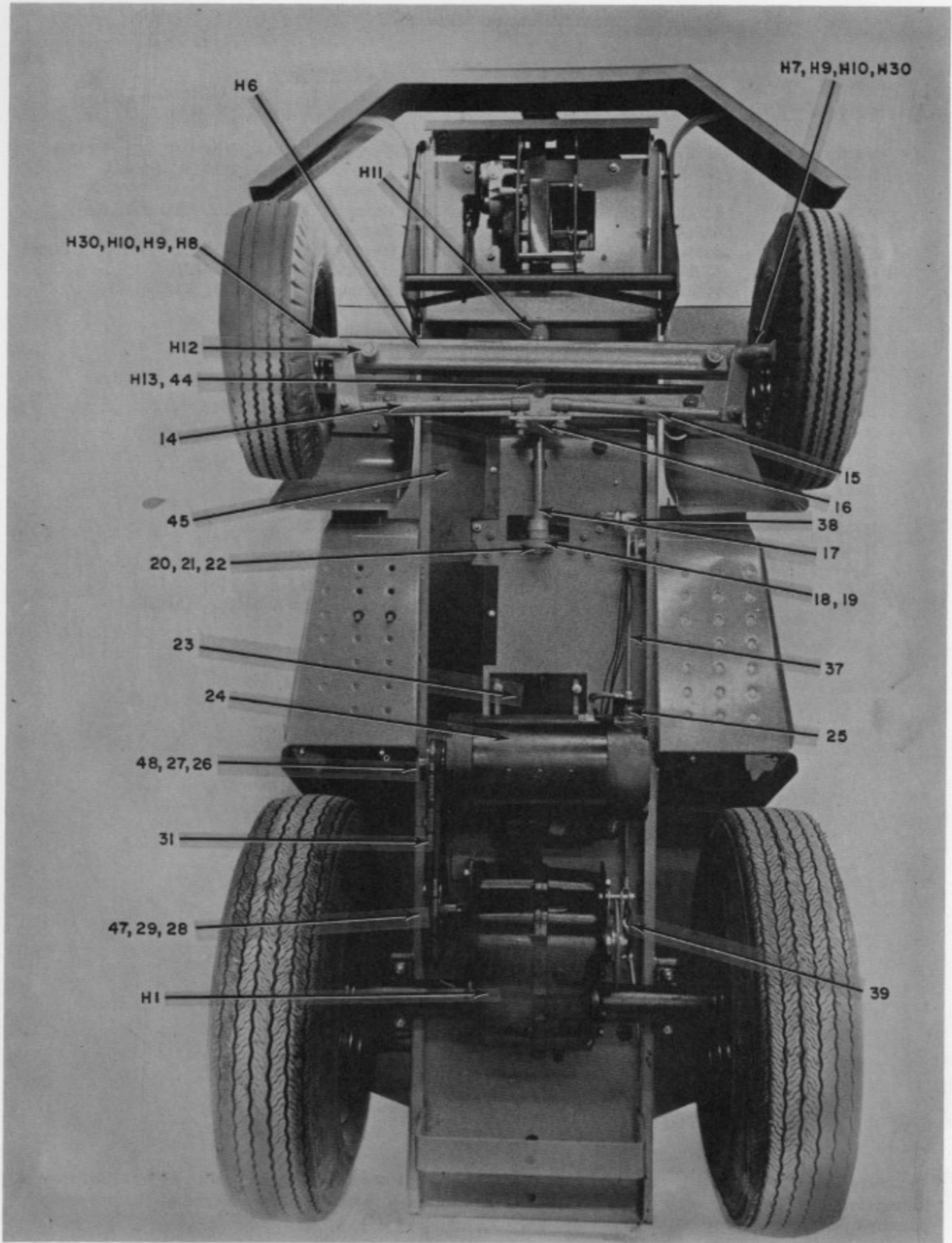

Fig. U-3

I-5 UNDERCARRIAGE COMPONENTS

<u>Ref. No.</u>	<u>Part No.</u>	<u>Description</u>
H-1	422D818P1	Transaxle
H-2	244A7028P1	Hub, Painted
H-3	N3400P809	Key (1/4 x 1 1/8)
H-4	N72P2316C6	Set Screw (5/16-18 x 1)
H-5	N213P23B6	Jam Nut (5/16-18)
H-6	178B8032G	Front Axle
H-7	178B8491G1	Spindle, Left
H-8	178B8490G1	Spindle, Right
H-9	N922P75C6	Snap Ring (Located on Spindle)
H-10	N402AP18B6	Washer (On Spindle)
H-11	243A4587P1	Thrust Washer (Located on Spindle)
H-12	243A4867P1	Grease Fitting
H-13	244A7416P1	Pivot Pin
H-15	541C950P1	Tie Rod and Ball Joint (R. H.)
H-16	541C950P2	Tie Rod and Ball Joint (L. H.)
H-17	243A4561P1	Bearing
H-18	542C898G5	Gear and Sector Assembly
H-19	541C902P2	Mounting Bracket
H-20	243A4590P1	Bearing (In Mounting Bracket)
H-21	N402AP18B6	Plain Washer
H-22	243A4613P1	Shim Washer
H-23	N503P1220B6	Cotter Pin - 1/8 x 1 1/4
H-24	541C915P2	Motor Plate
H-25	163B9996P1	Drive Motor
H-26	243A4859P1	Drive Motor Circuit Breaker
H-27	243A4785P1	Drive Motor Pulley
H-28	163B9877P1	Transaxle Pulley
H-29	N70P2312B6	Set Screw (5/16-18 x 3/4)
H-30	N3400P606	Key (3/16 x 3/4) Woodruff)
H-31	211A3226P4	Drive Belt (Pair)
H-32	423D275G1	Undercarriage Harness (CE20AA, BA Only)
H-32	127D8117G1	Undercarriage Harness (CE20CA Only)
H-33	243A4546P2	Collar
H-34	243A4540P1	Cable Tie (Small)
H-35	243A4540P2	Cable Tie (Large)
H-36	244A7211P1	Boot
H-37	211A3481P1	Brake Switch
H-38	N62P21024B6	Carriage Bolt (1/4-20 x 1 1/2)
H-39	N264P21B6	Locknut, Hex
H-40	243A4543P3	Clevis Pin (Brake)
H-41		Hairpin Cotter
H-42	244A7163P1	Cable Clip
H-43	N3402P6036	Key, Drive Motor (3/16 x 1 1/8)
H-44	N922P62C6	Snap Ring (Used on Pivot Pin)
H-45	178B8226P1	Wire Cover

FRONT BATTERY  
COMPARTMENT, L.F.

TABLE OF CONTENTS

FIGURE

TITLE

FB-1

Front Battery Compartment, Large Frame

FB-2

Front Battery Compartment, I-5

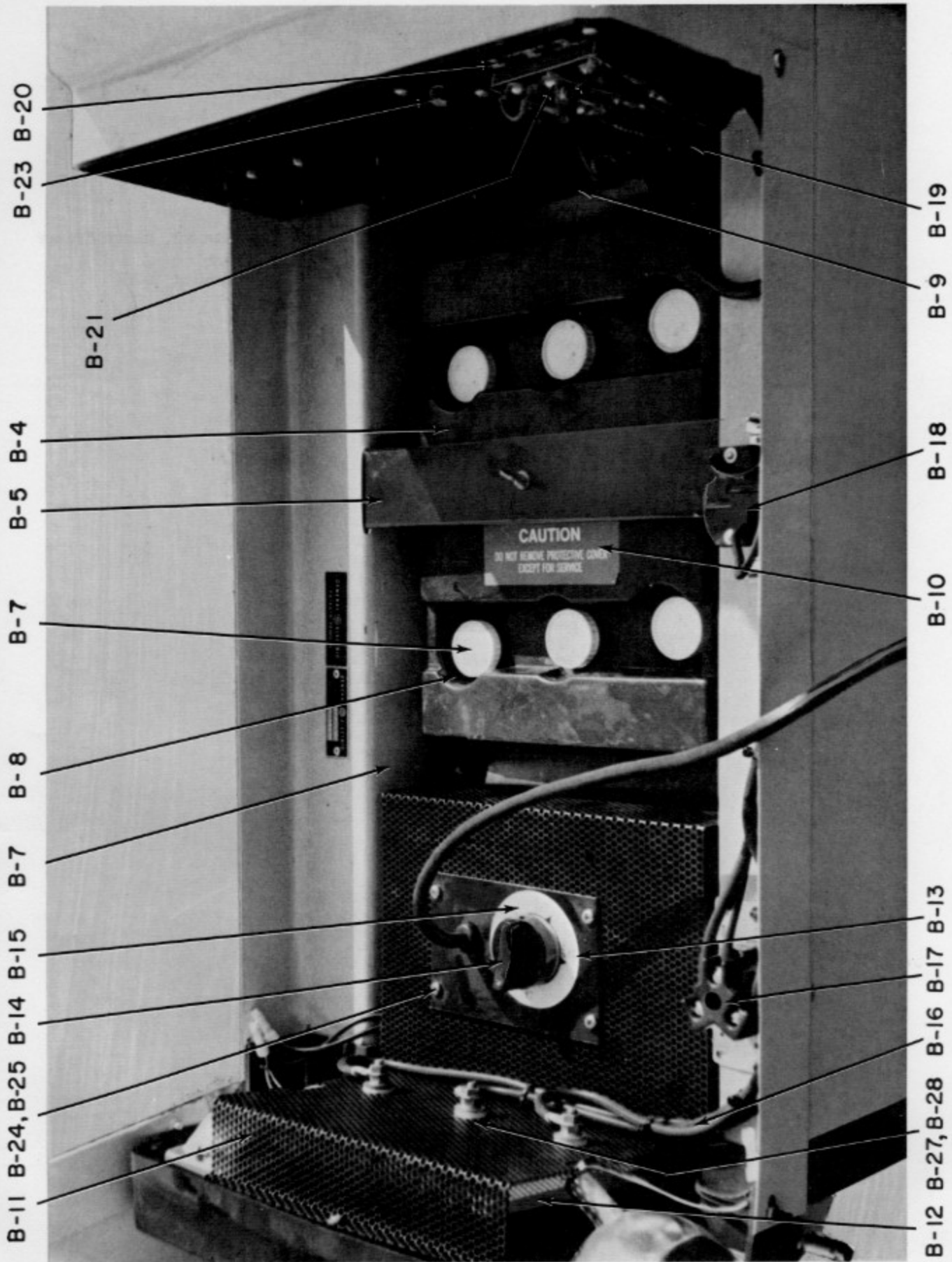

Fig. FB-1

FRONT BATTERY COMPARTMENT

(Large Frame)

<u>Ref. No.</u>	<u>Part No.</u>	<u>Description</u>
B-1	155C8070P1	Battery Tray (E12-EA)
B-1	155C8070P2	Battery Tray (E20-DA, EA, FA, E16AA, E15GA, HA, E14AA, RJ, E12JA, JD)
B-1	541C699P1	Battery Tray (All Other Models)
B-2	178B8165G1	Battery Cable (All Models)
B-4	243A4523G1	Battery Cover (All Models)
B-5	163B9887G1	Battery Clamp Asm. (All Models)
B-6	243A4724P1	H. D. Battery (All E20's, Optional for Others)
B-6	243A4527P1	Std. Battery (All E15's and E12's)
B-7	243A4849P1	Battery Cap, Old H. D. (As Required)
B-7	244A7420P1	Battery Cap, New Std. + H. D. (As Required)
B-8	155C8005P1	Poly Bag (All Models)
B-9	211A3598P2	Battery Protector (All Models)
B-11	178B8031G1	Charger Cover, Perforated (E20-AA, BA, CA, CB, CC, DA)
B-11	178B8286G1	Charger Cover, Louvered (E20-AA, BA, CA, CB, CC, DA)
B-11	541C917P1	Charger Cover, Perforated (E20-EA, EC, ED, FA, RA, All E15's, All E12's)
B-11	155C8160P1	Charger Cover, Louvered (E20-EA and Later, All E15's, All E12's, All E16's, All E14's)
B-12	178B8012G1	Power Resistor Asm. (E20-AA, BA, CA, CB, CC, DA)
B-12	178B8453G1	Power Resistor Asm. (E20-EA, EC, ED, FA, RA)
B-12	163B9904G1	Power Resistor Asm. (E15's + E12's + E16's + E14's)
B-13	163B9906G2	Timer Asm. (Uses Dial 211A3498P3)
B-13	163B9906G4	Timer Asm. (Uses Dial 244A7386P1)
B-14	243A4549P1	Timer Knob (All Models)
B-15	211A3498P1	Timer Dial (All Models with 1-2 Years, 3-5 Years, etc. Dial)
B-15	244A7386P1	Timer Dial (All Models with A-J Dial)
B-16	155C8019G1	Grill Harness (E20-AA, BA, CA, CB, CC, DA)
B-16	158C9053G1	Grill Harness (E20-EA, EC, ED, FA, RA, E16AA, RA, RB, RD, E15HA, JA, E14AA, RJ, E12JA, JD)
B-16	541C924G1	Grill Harness (E15-AA)
B-16	541C958G1	Grill Harness (E15-BA, CA, CB, DA)
B-16	155C8084G1	Grill Harness (E15-EA, FA, GA)
B-16	158C9007G1	Grill Harness (E14RH, E12HA)
B-16	541C958G2	Grill Harness (E12-AA, BA)
B-16	541C944G1	Grill Harness (E14RC, RD, E12CA, DA)
B-16	155C8064G1	Grill Harness (E12-EA)
B-17	243A4572P1	P. T. O. Outlet (All Models)
B-18	243A4542P1	Accessory Outlet (All Models)
B-19	244A7463P1	Fuse Board (E20DA, EA, EC, ED, FA, RA, E16AA, RA, RB, RD, E15GA, HA, JA, E14AA, RJ, E12JA, JD)
B-19	243A4807P1	Fuse Board (E20-AA, BA, CA, CB, CC, E15-EA, FA, E14RC, RD, RH, E12-CA, DA, EA, HA)
B-19	243A4591P1	Fuse Boards (E15-AA, BA, CA, CB, DA, E12-AA, BA)
B-20	211A3528P1	Fuse Decal (All Models)
B-22	243A4657P1	Fuse, 20 Amp. (All Models)
B-21	243A4597P1	Fuse, 30 Amp. (All Models Except E-12-EA)
B-23	243A4719P1	Circuit Breaker, 50 Amp. (All Models)
B-24	211A3562P1	Speed Nut (All Models)
B-25	N80P16006B6	10-24 x 3/8 Pan Hd. Screw (All Models)
B-26	163B9878G1	Headlight Assembly (Includes Reflector & Light Asm. Lamp, Lens, Spacer & Hardware)
B-27	211A3212P2	Fiber Washer
B-28	211A3212P1	Fiber Spacer

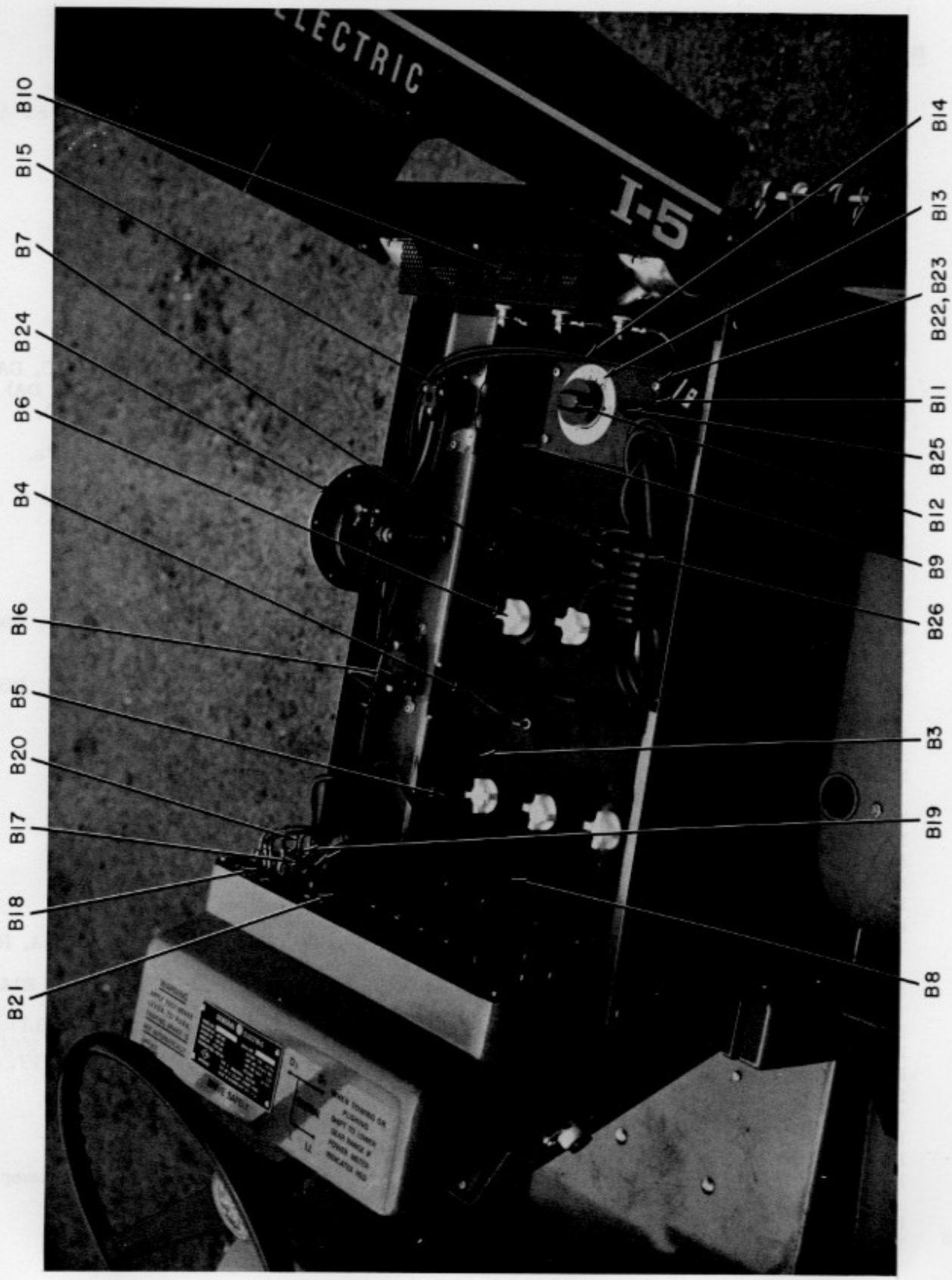



Fig. FB-2

### I-5 FRONT BATTERY COMPARTMENT

<u>Ref. No.</u>	<u>Part No.</u>	<u>Description</u>
B-1	155C8070P2	Battery Tray
B-2	178B8165G1	Battery Cable
B-3	243A4523G1	Battery Cover
B-4	163B9887G1	Battery Clamp Asm.
B-5	243A4724G1	H. D. Battery
B-6	244A7420P1	Battery Cap
B-7	155C8005P1	Poly Bag
B-8	211A3598P2	Battery Protector
B-9	541C917P1	Charger Cover
B-10*	178B8453G1	Power Resistor Asm. (CE20CA)
B-11	163B9906G4	Timer Asm.
B-12	243A4549P1	Timer Knob
B-13	244A7386P1	Timer Dial
B-14	158C9053G1	Grill Harness
B-15	243A4572P1	P. T. O. Outlet
B-16	243A4542P1	Accessory Outlet
B-17	244A7463P1	Fuse Block
B-18	211A3528P1	Fuse Decal
B-19	243A4657P1	Fuse, 20 Amp.
B-20	243A4597P1	Fuse, 30 Amp.
B-21	243A4719P1	Circuit Breaker, 50 Amp.
B-22	211A3562P1	Speed Nut (Charger Cover)
B-23	N80P17006B6	10-24 x 3/8 Pan Hd. Screw - (Charger Cover)
B-24	243A4883P1	Horn
B-25	243A4529P1	Strain Relief Bushing
B-26	211A3555G1	Charger Cord Asm. (With Terminals)
B-10*	178B8012G1	Power Resistor Asm. (CE20AA, BA)

\*When ordering this item it is imperative that care be taken to specify the model number and serial number of the tractor to insure your receiving the proper part.

ACCESSORIES



## ACCESSORIES

See the table of contents for a complete listing of attachments and accessories included in this section.

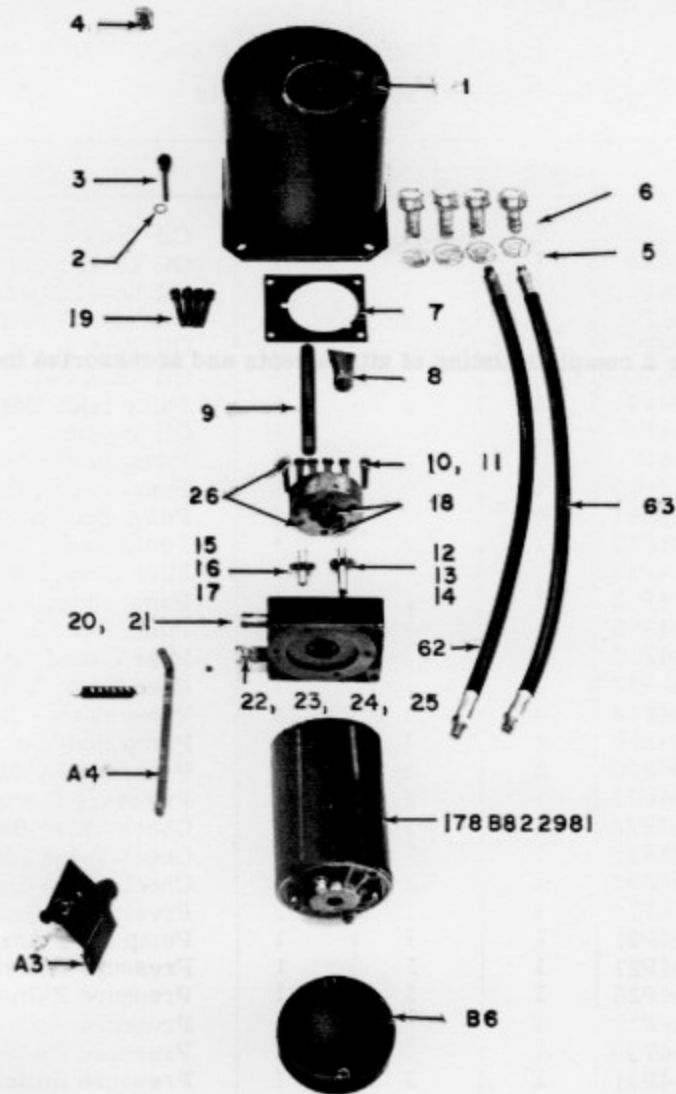

Power Pack

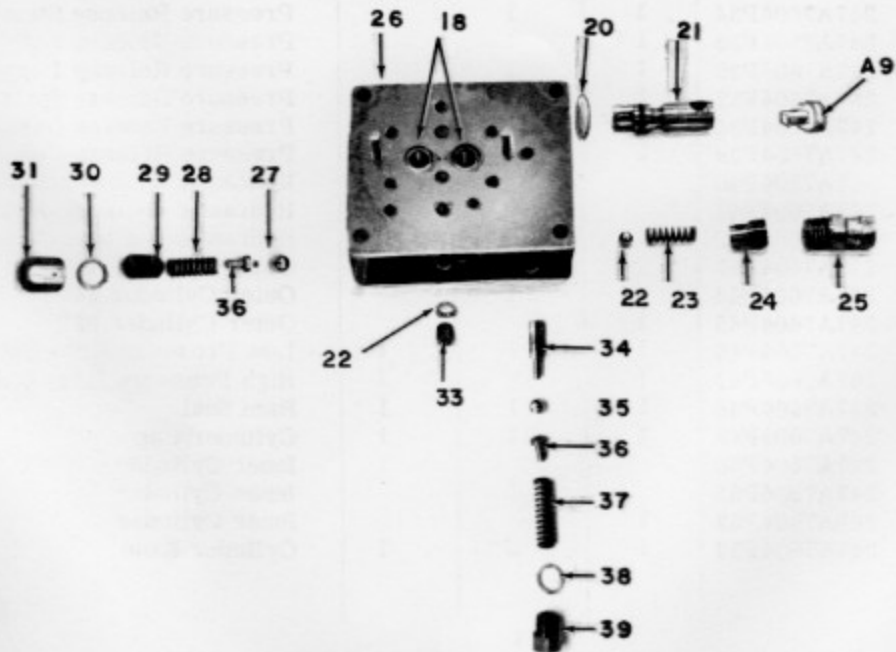

Pump Body Assembly  
16-2

**FORK LIFT**

Models CF92, CF74, CF48

Ref. No.	Part No.	Model			Description
		CF92	CF74	CF48	
1	247A7604P1	1	1	1	Oil Tank
2	247A7604P2	1	1	1	Oil Level Dipstick Gasket
3	247A7604P3	1	1	1	Oil Level Dipstick
4	247A7604P4	1	1	1	Oil Tank Pipe Plug
5	247A7604P5	4	4	4	Oil Tank Screw L Washer
6	247A7604P6	4	4	4	Oil Tank Cap Screw
7	247A7604P7	1	1	1	Pump Body Gasket
8	247A7604P8	1	1	1	Oil Strainer
9	247A7604P9	1	1	1	Pump Intake Nipple
10	247A7604P10	6	6	6	Pump Body Cap Screw
11	247A7604P11	6	6	6	Pump Body Screw Gasket
12	247A7604P12	1	1	1	Pump Gear
13	247A7604P13	1	1	1	Idler Gear Drive Pin (Long Shaft)
14	247A7604P14	1	1	1	Pump Drive Shaft
15	247A7604P15	1	1	1	Pump Gear
16	247A7604P16	1	1	1	Idler Gear Drive Pin (Short Shaft)
17	247A7604P17	1	1	1	Idler Gear Shaft
18	247A7604P18	4	4	4	Pump Needle Bearing
19	247A7604P19	4	4	4	Pump Body Screw/Washer
20	247A7604P20	1	1	1	Pressure Release "0" Ring
21	247A7604P21	1	1	1	Pressure Release Cam
22	247A7604P22	1	1	1	Check Valve Ball
23	247A7604P23	1	1	1	Check Valve Spring
24	247A7604P24	1	1	1	Check Valve Spring Cap
25	247A7604P25	1	1	1	Pressure Release Line Union
26	247A7604P26	1	1	1	Pump Body Assembly
27	247A7604P27	1	1	1	Pressure Relief Ball
28	247A7604P28	1	1	1	Pressure Relief Spring
29	247A7604P29	1	1	1	Pressure Relief Adjusting Screw
30	247A7604P30	1	1	1	Pressure Relief Gasket
31	247A7604P31	1	1	1	Pressure Relief Valve Cap
32	247A7604P32	1	1	1	Oil Seal
33	247A7604P33	1	1	1	Pipe Plug
34	247A7604P34	1	1	1	Pressure Release Stem
35	247A7604P35	1	1	1	Pressure Release Ball
36	247A7604P36	1	1	1	Pressure Release Poppet
37	247A7604P37	1	1	1	Pressure Release Spring
38	247A7604P38	1	1	1	Pressure Release Gasket
39	247A7604P39	1	1	1	Pressure Release Cup
40	247A7604P40			1	Hydraulic Cylinder Asm. 48"
41	247A7604P41		1		Hydraulic Cylinder Asm. 74"
42	247A7604P42	1			Hydraulic Cylinder Asm. 92"
43	247A7604P43			1	Outer Cylinder 48"
44	247A7604P44		1		Outer Cylinder 74"
45	247A7604P45	1			Outer Cylinder 92"
46	247A7604P46	1	1	1	Low Pressure Hose Union
47	247A7604P47	1	1	1	High Pressure Hose Union
48	247A7604P48	1	1	1	Ram Seal
49	247A7604P49	1	1	1	Cylinder Cap
50	247A7604P50			1	Inner Cylinder
51	247A7604P51		1		Inner Cylinder
52	247A7604P52	1			Inner Cylinder
53	247A7604P53	1	1	1	Cylinder Base

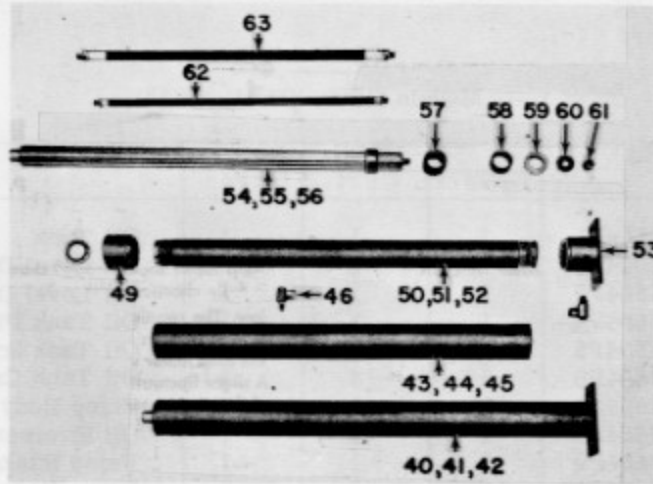

Hydraulic Cylinder Assembly

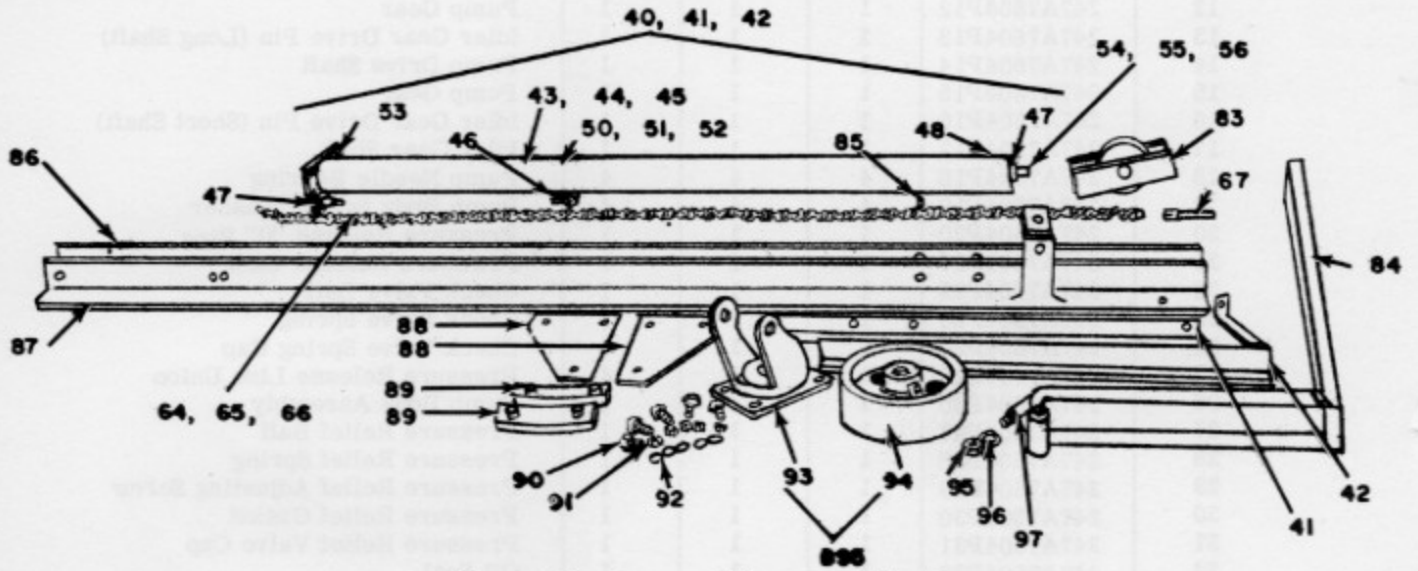

Support Structure and Component Parts

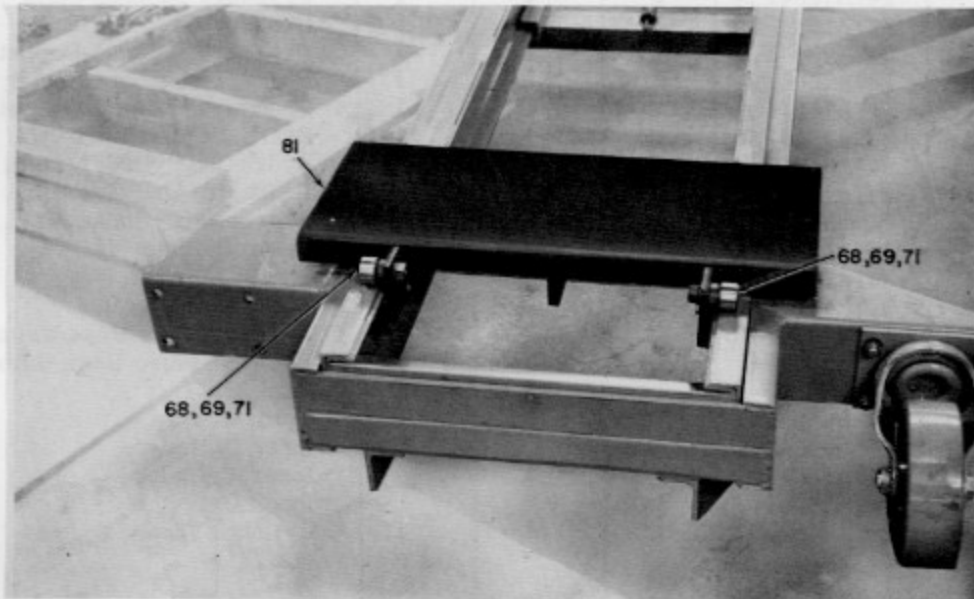

Back Plate Roller Bearings

Ref No.	Part No.	Model			Description
		CF92	CF74	CF48	
54	247A7604P54			1	Ram, 48"
55	247A7604P55		1		Ram, 74"
56	247A7604P56	1			Ram, 92"
57	247A7604P57	1	1	1	Chevon Set
58	247A7604P58	1	1	1	Chevon Spring
59	247A7604P59	1	1	1	Ram Guide
60	247A7604P60	1	1	1	Ram Guide Washer
61	247A7604P61	1	1	1	Ram Guide Nut
62	247A7604P62	1	1	1	Low Pressure Hose
63	247A7604P63	1	1	1	High Pressure Hose
64	247A7604P64			1	Chain, 48"
65	247A7604P65		1		Chain, 74"
66	247A7604P66	1			Chain, 92"
67	247A7604P67	1	1	1	Chain Socket Assembly
68	247A7604P68	4	4	4	Hood Bearing
69	247A7604P69	1	1	1	Hood Bearing Spacer
70	247A7604P70	1	1	1	Hood Bearing Lockwasher
71	247A7604P71	1	1	1	Hood Bearing Nut
72	247A7604P72	1	1	1	Bearing Bracket, Left
73	247A7604P73	1	1	1	Bearing Bracket, Right
74	247A7604P74	1	1	1	Thrust Bearing Screw
75	247A7604P75	1	1	1	Thrust Bearing
76	247A7604P76	1	1	1	Thrust Bearing Back Washer
77	247A7604P77	1	1	1	Thrust Bearing Holder
78	247A7604P78	1	1	1	Thrust Bearing Cap Screw
79	247A7604P79	1	1	1	Thrust Bearing Nut
80	247A7604P80	1	1	1	Thrust Bearing Holder Screw and Washer
81	247A7604P81	1	1	1	Thrust Bearing Holder Adjusting Screw
82	247A7604P82	1	1	1	Fork Back Plate
83	247A7604P83	1	1	1	Chain Roller Assembly
84	247A7604P84	2	2	2	Fork, 36"
85	247A7604P85	1	1	1	Vent Plug
86	247A7604P86	1	1	1	Lift-to-Tractor Support Arm, Right
87	247A7604P87	1	1	1	Lift-to-Tractor Support Arm, Left
88	247A7604P88	1	1	1	Lift Rear Mount Bracket
89	247A7604P89	2	2	2	Rubber Bumpers
90	247A7604P90	4	4	4	Caster Cap Screw
91	247A7604P91	4	4	4	Caster Hex Nut
92	247A7604P92	4	4	4	Caster Lockwasher
93	247A7604P93	2	2	2	8" Caster Horn
94	247A7604P94	2	2	2	8" Polyurethane Wheel
95	247A7604P95	2	2	2	Wheel Nut
96	247A7604P96	2	2	2	Wheel Lockwasher
97	247A7604P97	2	2	2	Wheel Axle
98	247A7604P98			1	Lift Support Bracket with Control Arm
99	247A7604P99		1		Lift Support Bracket with Control Arm
A1	247A7604PA1	1			Lift Support Bracket with Control Arm
A2	247A7604PA2	1	1	1	Lift Support Bracket
A3	247A7604PA3	1	1	1	Switch Bracket and Switch
A4	247A7604PA4	1	1	1	Release Handle

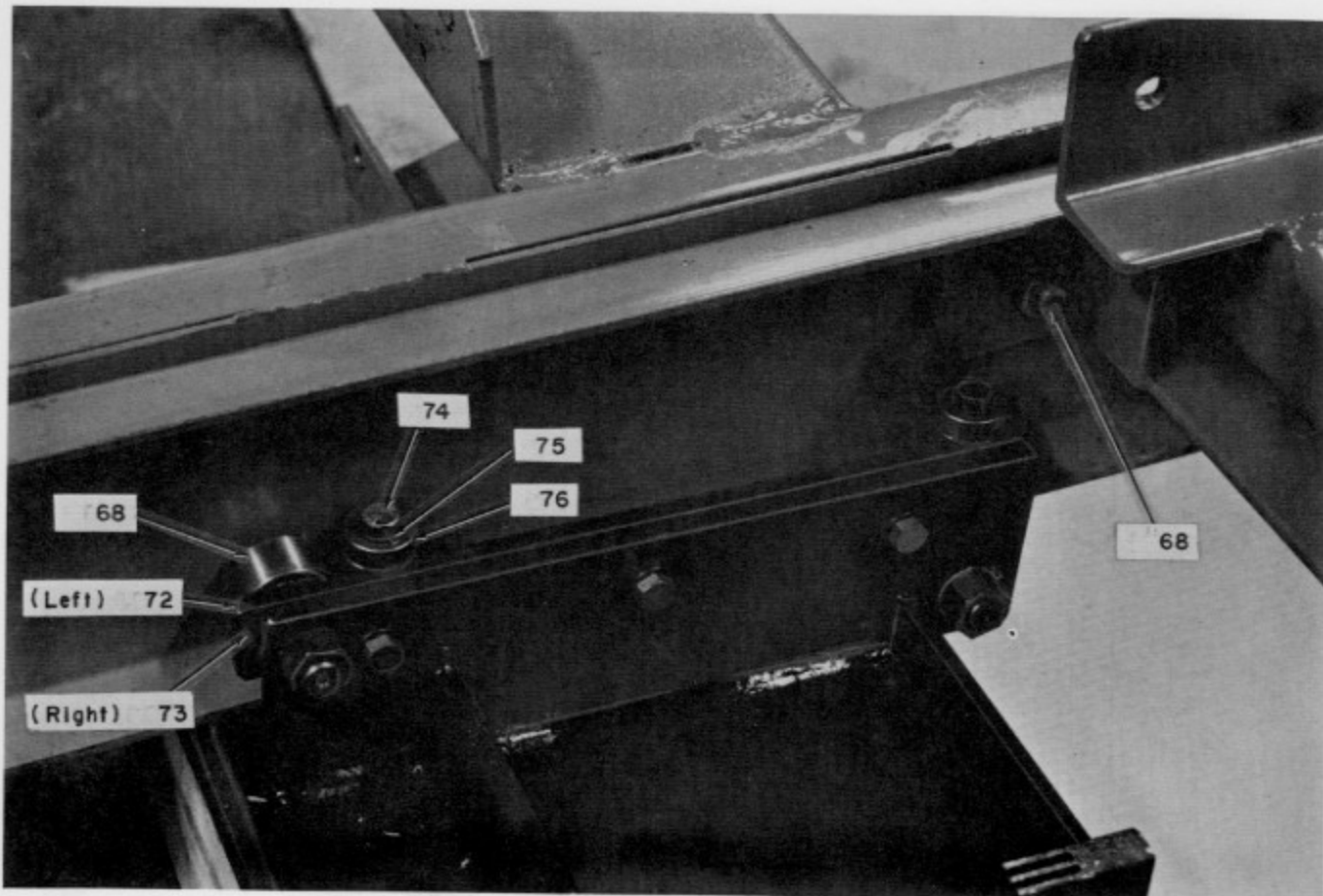

Back Plate Roller Bearings

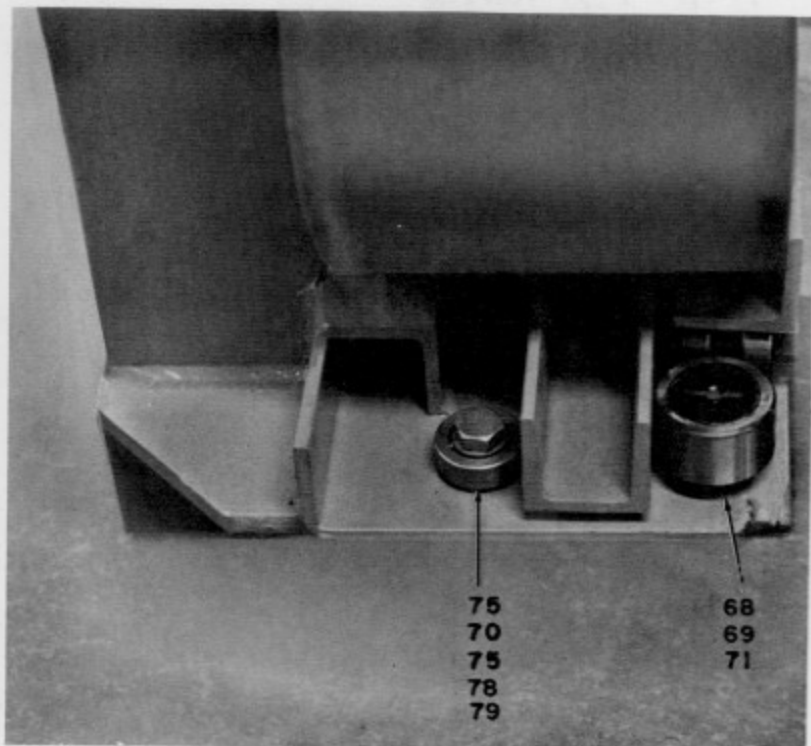

Mast Roller Bearings

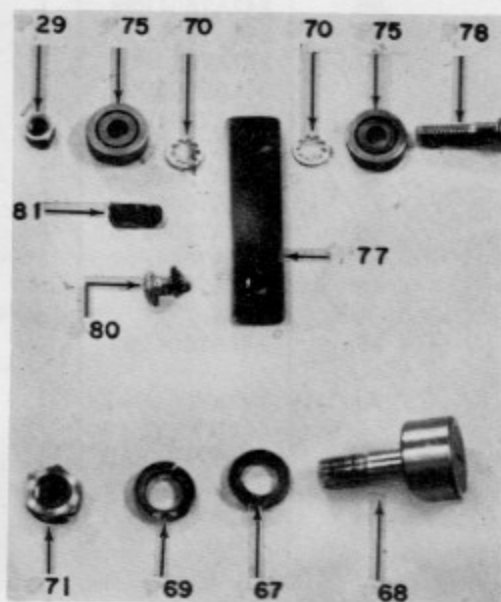

Roller Assembly

Ref. No.	Part No.	Model			Description
		CF92	CF74	CF48	
A5	247A7604PA5	1	1	1	Control Handle Pivot
A6	247A7604PA6	1	1	1	Control Handle, Long
A7	247A7604PA7	1	1	1	Control Handle, Short
A8	247A7604PA8	1	1	1	Control Handle Ball
A9	247A7604PA9	1	1	1	Oldham Coupling
B2	247A7604B1	1	1	1	Release Handle Spring
B3	247A7604B2	1	1	1	Switch Bracket
B4	247A7604B3	1	1	1	Switch
B5	247A7604B4	2	2	2	Polyurethane Caster
B6	247A7604B5	1	1	1	Cover

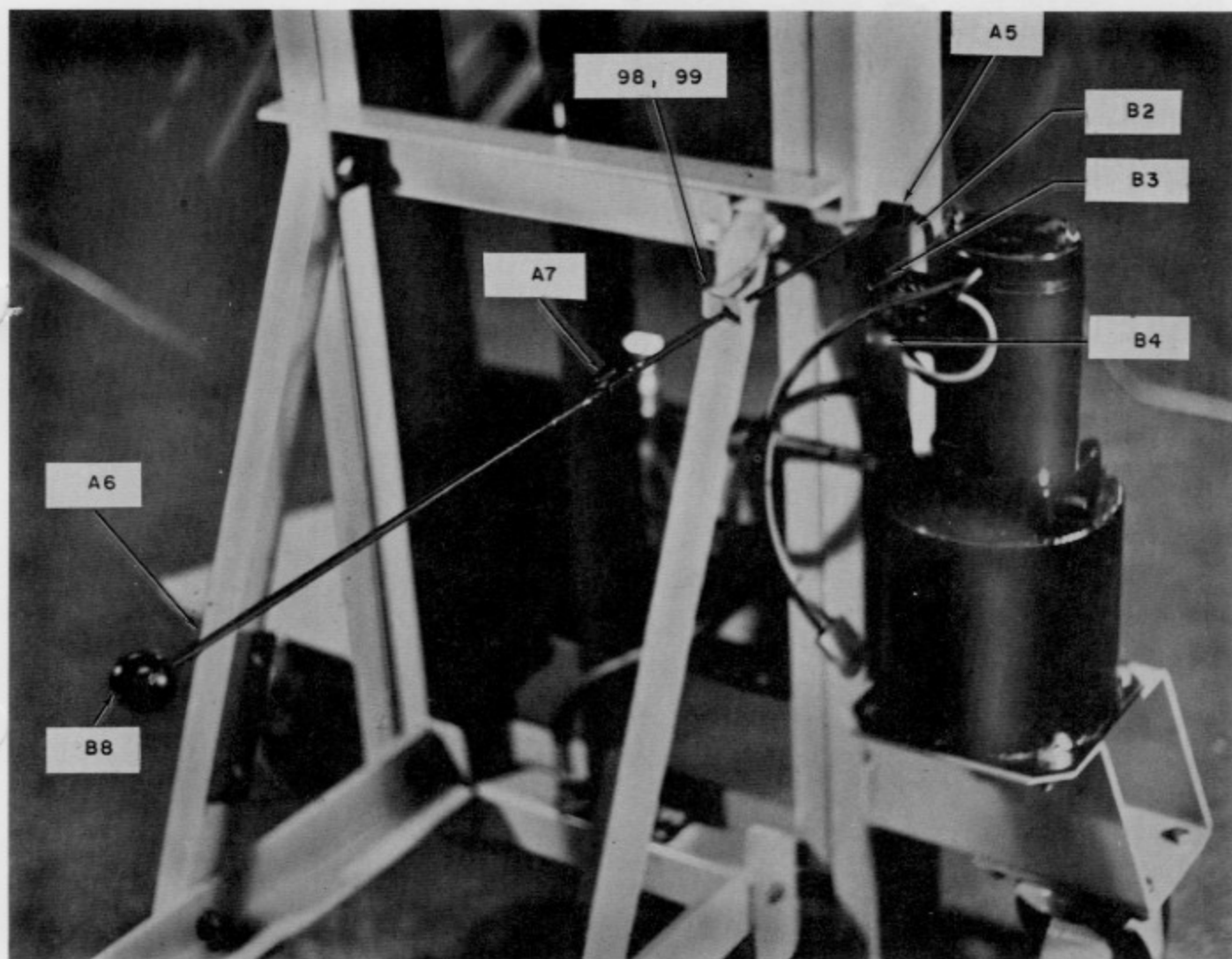

Hand Control

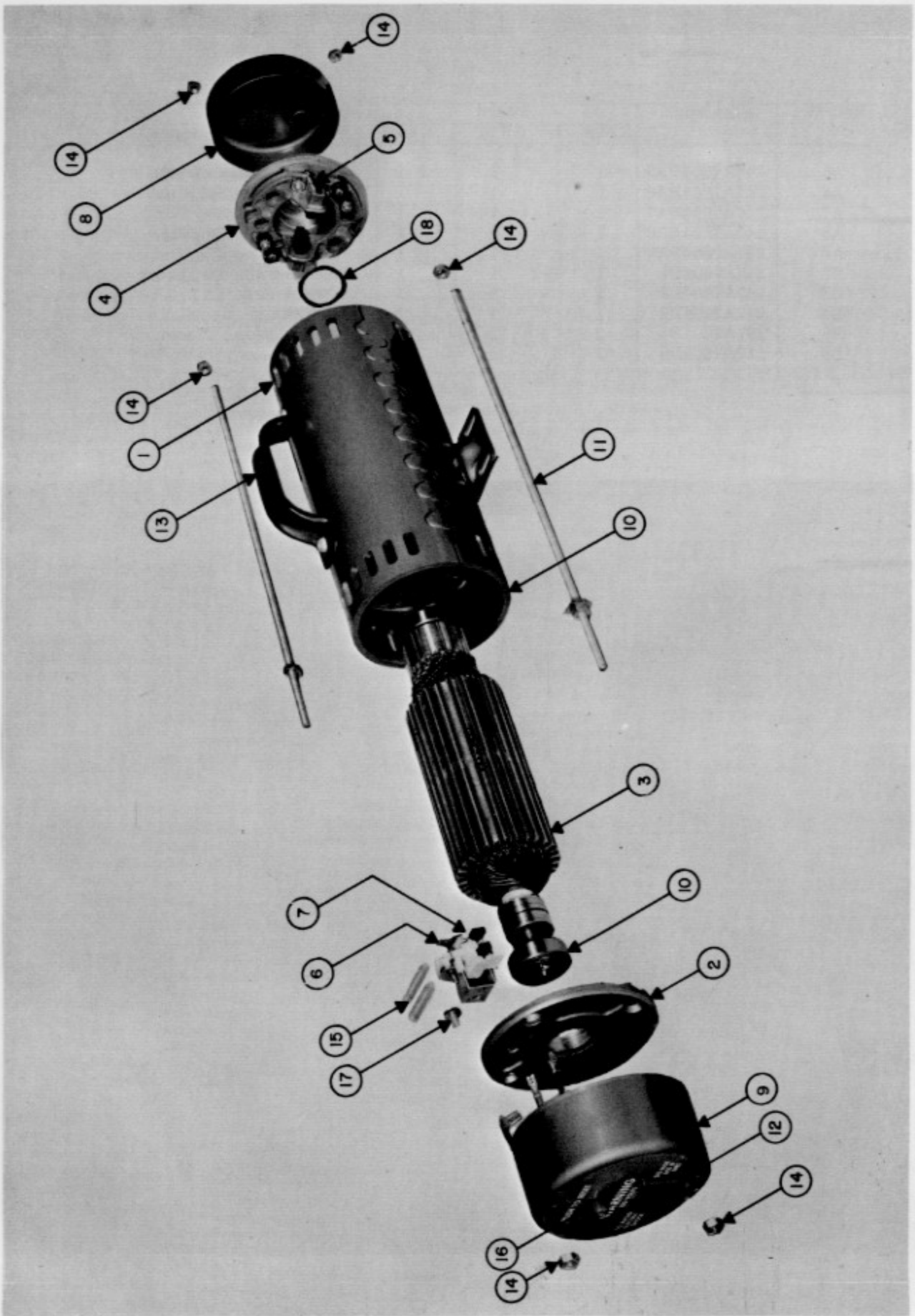

INVERTER SPARE PARTS  
Model CE12

<u>Ref. No.</u>	<u>Part No.</u>	<u>Description</u>
1		Shell & Magnet Asm., P1000-959
2		Fr. End Bell Asm., w/o Brush Holder P1005-108
3		Armature Asm., w/Brushes, P2000-1030
4		Rear End Bell Asm., w/Brushes, P1026-125
5		Brush Asm., (DC), P1009-25
6		Brush Holder (AC), P1204-1
7		Brush Asm. (AC), P1009-22
8		Cover, P1033-45
9		Cover w/Reset (AC), P1033-83
10	244A7329P5	Bearing, P2007-2
11		Thr'd. Rod, H1-7
12		Snap-in Outlet, P3316-3
13		Handle, P1260-1
14	N210P21B6	Nut, 1/4-20
15		Spring
16	211A3526P2	Manual Reset
17		Screw
18		Washer

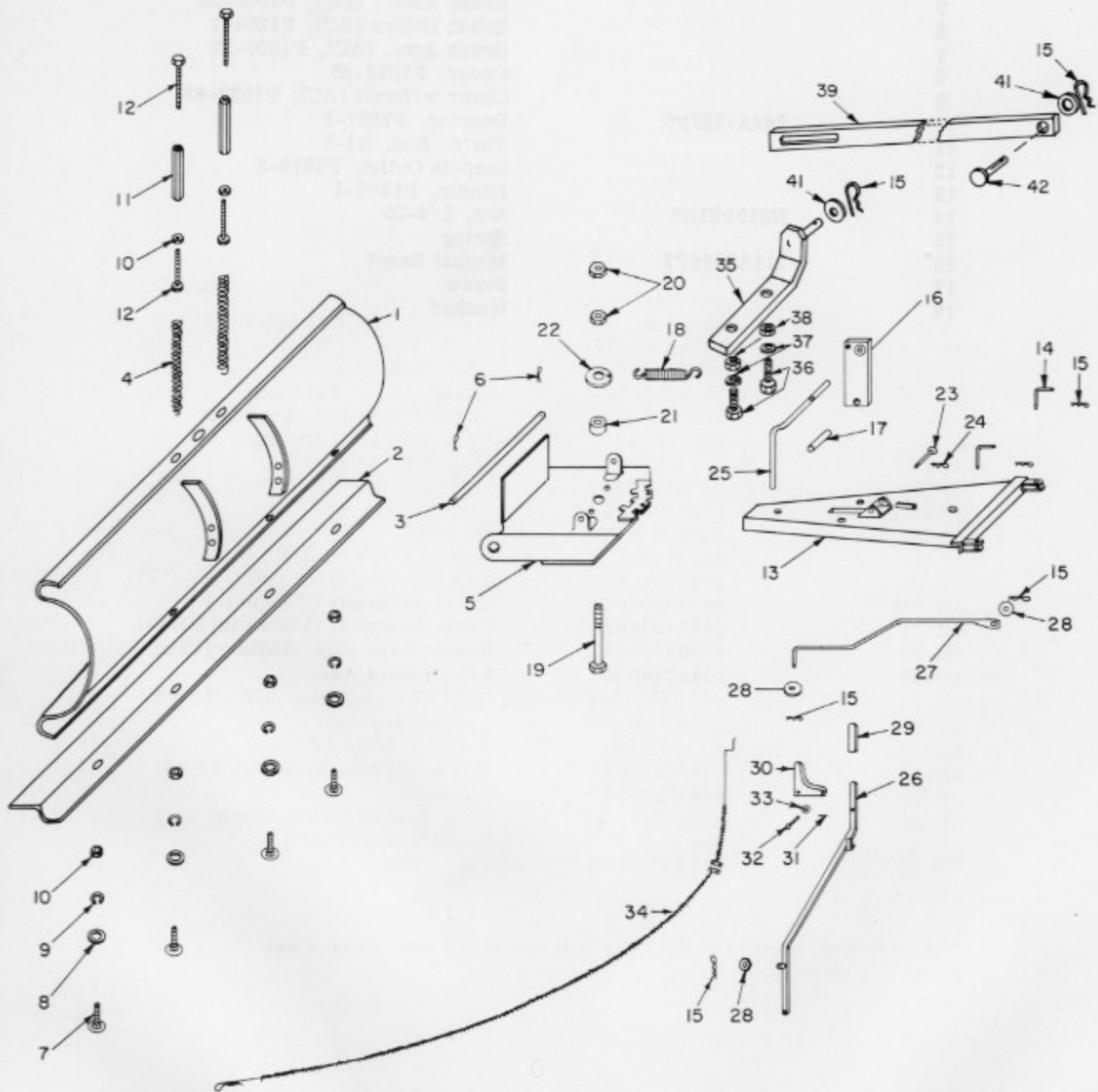

REFERENCE NUMBER IS NUMBER ON DRAWING PREFIXED BY AB.

## 48" SNOW/DOZER BLADE

Model AB48

<u>Ref. No.</u>	<u>Part No.</u>	<u>Description</u>
AB-1	243A4890G1	Blade Assembly 48"
AB-2	178B8059P1	Bar, Wear and Skid
AB-3	243A4891P1	Pivot Rod
AB-4	243A4892P1	Spring, Blade Trip
AB-5	243A4893G1	Pivot Plate Assembly
AB-6	See Note 1	Pin, Cotter (5/32" x 1 1/4")
AB-7	See Note 1	Carriage Bolt (3/8"-16 x 1")
AB-8	See Note 1	Plain Washer (3/8")
AB-9	See Note 1	Lockwasher (3/8")
AB-10	See Note 1	Hex Nut (3/8"-16)
AB-11	243A4894P1	Nut, Coupler (3/8"-16 x 1 1/2")
AB-12	See Note 1	Hex Bolt (3/8"-16 x 1 1/2")
AB-13	155C8009G1	Push Tube Assembly
AB-14	243A4895P1	Pin, Drilled
AB-15	243A4543P1	Hair Pin Cotter
AB-16	243A4896P1	Pivot Bar, Lock
AB-17	N533P2516B	Pin, Spring
AB-18	243A4897P1	Spring, Angle Lock
AB-19	N22P35072B6	Hex Hd. Bolt
AB-20	N213P35B6	Hex Jam Nuts
AB-21	243A4898P1	Spacer
AB-22	243A4899P1	Washer - Latch Spring Conn.
AB-23	211A3505P12	Clevis Pin
AB-24	211A3256P4	Hair Pin Cotter
AB-25	178B8081G1	Handle, Pivot Bar Lock
AB-26*	178B8058G1	Handle Assembly, Angling
AB-27*	243A4903G1	Rod Assembly, Angling
AB-28	See Note 1	Plain Washer (5/8")
AB-29	243A4837P1	Handle Grip, Vinyl
AB-30	178B8060P1	Hand Lever
AB-31	N509P1308B	Roll Pin
AB-32	See Note 1	Hex Bolt (1/4" x 3/4")
AB-33	See Note 1	Hex Lock Nut (1/4"-20)
AB-34*	243A4904P1	Cable Assembly (Complete)
AB-34	243A4904P2	Cable Assembly (Used with KB 48)
AB-26	178B8199G1	Handle Assembly, Angling (Used with KB 48)
AB-35	244A7456G1	Lift Bracket Asm.
AB-36	N22P25048B6	Hex Headcap Screw 3/8 - 16 x 3
AB-37	N405P13C6	Lockwasher 3/8
AB-38	N210P25B6	Hex Nut 3/8 - 16
AB-27	244A7238G1	Rod Assembly (Used with KB 48)
AB-39	244A7223P1	Lift Bar
AB-40	178B8207P1	Drill Template (Not Shown)
AB-41	See Note 1	Plain Washer (1/2")
AB-42	211A3505P20	Clevis Pin

(1) Not stocked, order locally. For bolt and screw replacement use Grade 5 or better.

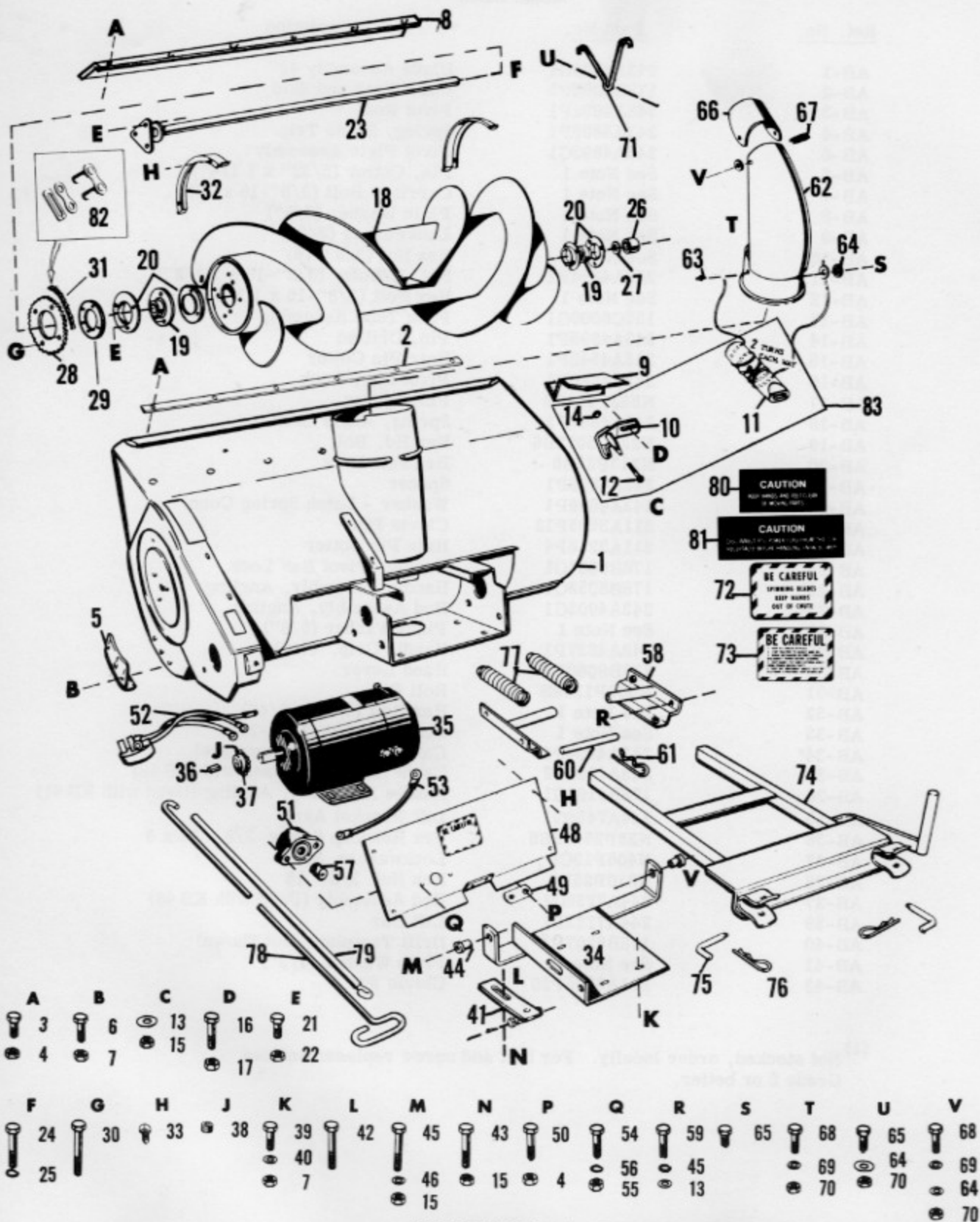

REFERENCE NUMBER IS THE NUMBER ON THE DRAWING PRECEDED BY "AD"

SNOW THROWER

Model AD42AA

<u>Ref. No.</u>	<u>Part No.</u>	<u>Description</u>
AD-1	243A4714P1	Assy. - Header Housing
AD-2	243A4714P2	Blade - Scraper
AD-3	243A4714P3	Bolt - 1/4-20 x 5/8 Carr.
AD-4	N238P21C6	Nut and Lock Washer Assembly (1/4-20 Hex.)
AD-5	178B8411P1	Shoe - Skid
AD-6	N657P23012B6	Bolt - 5/16-18 x 3/4 Carr.
AD-7	N256P23C6	Nut and Lockwasher Assembly (5/16-18 Hex.)
AD-8	243A4714P8	Deflector - Snow
AD-9	243A4714P9	Support - Stack Drive Brkt.
AD-10	243A4714P10	Assembly - Stack Drive Brkt.
AD-11	243A4714P11	Assembly - Tube and Cable (Comp.)
AD-12	243A4714P12	Eye Bolt - Drive Tube
AD-13	N402AP43B6	Washer - 3/8 Flat
AD-14	243A4714P14	Spring Washer - Stack Control Rod
AD-15	N264P25B6	Nut - 3/8-16 Hex. Lock
AD-16	N657P25016B6	Bolt - 3/8-16 x 1 Carr.
AD-17	N256P25C6	Nut and Lockwasher Assembly (3/8-16 Hex.)
AD-18	243A4714P18	Assembly - Auger (AW)
AD-19	243A4714P19	Bearing - Auger
AD-20	243A4714P20	Flangette - Bearing
AD-21	N22P23010B6	Bolt - 5/16-18 x 5/8 Hx. Hd.
AD-22	N405P42C6	Washer - 5/16 Med. Lock
AD-23	243A4714P23	Assembly - Auger Shaft (42")
AD-24	N22P29020B6	Bolt - 1/2-13 x 1-1/4 Hx. Hd.
AD-25	N405P45C6	Washer - 1/2 Med. Lock
AD-26	243A4714P26	Spacer - Auger Shaft
AD-27	243A4714P27	Washer
AD-28	243A4714P28	Sprocket - Auger Drive (45 Tooth)
AD-29	243A4714P29	Spacer - Sprocket
AD-30	N22P23032B6	Bolt - 5/16-18 x 2 Hx. Hd.
AD-31	243A4714P31	Chain - Auger Drive (82 Links)
AD-32	243A4714P32	Guard - Chain (Galvanized)
AD-33	N154P2408C	Screw - Self Tapping
AD-34	243A4714P34	Assembly - Mounting Plate
AD-35	178B8170P1	Motor
AD-36	243A4714P36	Key - 3/16 x 1" Long
AD-37	243A4714P37	Sprocket - Motor Shaft (13 Tooth)
AD-38	243A4714P38	Screw - Set (5/16-18 x 5/16)
AD-39	N657P23012B6	Bolt
AD-40	244A7365P1	Washer - Flat (5/16 x 3/4 x .065)
AD-41	243A4714P41	Assembly - Adjustment Brkt.
AD-42	N22P25032B6	Bolt - 3/8-16 x 2 Hx. Hd.
AD-43	N22P25024B6	Bolt - 3/8-16 x 1-1/2 Hx. Hd.
AD-44	243A4714P44	Trunnion
AD-45	N405P43C6	Washer - 3/8 Med. Lock
AD-46	N22P25020B6	Bolt - 3/8-16 x 1-1/4 Hx. Hd.
AD-47	N22P25012B6	Bolt - 3/8-16 x 3/4 Hx. Hd.
AD-48	243A4714P48	Plate - Motor Cover
AD-49	247A7366P1	Clamp
AD-50	N22P21016B6	Bolt - 1/4-20 x 2 Hx. Hd.
AD-51	243A4606P1	Circuit Breaker
AD-52	243A4579G1	Cord Assembly
AD-53	211A3556G8	Jumper Wire
AD-54	N37P17014B6	Machine Screw (10-24 x 7/8)
AD-55	N210P17B6	Nut - 10-24 Hex.
AD-56	N405P39B6	Washer - #10 Med. Lock
AD-57	243A4714P57	Button Plug (Plastic)

WORK SHEETS

Sheet No. 10

Part No.	Description	Part No.
AD-1	Washer - 1/2" x 1/4" x 1/8"	WASHER
AD-2	Washer - 1/2" x 1/4" x 1/8"	WASHER
AD-3	Washer - 1/2" x 1/4" x 1/8"	WASHER
AD-4	Washer - 1/2" x 1/4" x 1/8"	WASHER
AD-5	Washer - 1/2" x 1/4" x 1/8"	WASHER
AD-6	Washer - 1/2" x 1/4" x 1/8"	WASHER
AD-7	Washer - 1/2" x 1/4" x 1/8"	WASHER
AD-8	Washer - 1/2" x 1/4" x 1/8"	WASHER
AD-9	Washer - 1/2" x 1/4" x 1/8"	WASHER
AD-10	Washer - 1/2" x 1/4" x 1/8"	WASHER
AD-11	Washer - 1/2" x 1/4" x 1/8"	WASHER
AD-12	Washer - 1/2" x 1/4" x 1/8"	WASHER
AD-13	Washer - 1/2" x 1/4" x 1/8"	WASHER
AD-14	Washer - 1/2" x 1/4" x 1/8"	WASHER
AD-15	Washer - 1/2" x 1/4" x 1/8"	WASHER
AD-16	Washer - 1/2" x 1/4" x 1/8"	WASHER
AD-17	Washer - 1/2" x 1/4" x 1/8"	WASHER
AD-18	Washer - 1/2" x 1/4" x 1/8"	WASHER
AD-19	Washer - 1/2" x 1/4" x 1/8"	WASHER
AD-20	Washer - 1/2" x 1/4" x 1/8"	WASHER
AD-21	Washer - 1/2" x 1/4" x 1/8"	WASHER
AD-22	Washer - 1/2" x 1/4" x 1/8"	WASHER
AD-23	Washer - 1/2" x 1/4" x 1/8"	WASHER
AD-24	Washer - 1/2" x 1/4" x 1/8"	WASHER
AD-25	Washer - 1/2" x 1/4" x 1/8"	WASHER
AD-26	Washer - 1/2" x 1/4" x 1/8"	WASHER
AD-27	Washer - 1/2" x 1/4" x 1/8"	WASHER
AD-28	Washer - 1/2" x 1/4" x 1/8"	WASHER
AD-29	Washer - 1/2" x 1/4" x 1/8"	WASHER
AD-30	Washer - 1/2" x 1/4" x 1/8"	WASHER
AD-31	Washer - 1/2" x 1/4" x 1/8"	WASHER
AD-32	Washer - 1/2" x 1/4" x 1/8"	WASHER
AD-33	Washer - 1/2" x 1/4" x 1/8"	WASHER
AD-34	Washer - 1/2" x 1/4" x 1/8"	WASHER
AD-35	Washer - 1/2" x 1/4" x 1/8"	WASHER
AD-36	Washer - 1/2" x 1/4" x 1/8"	WASHER
AD-37	Washer - 1/2" x 1/4" x 1/8"	WASHER
AD-38	Washer - 1/2" x 1/4" x 1/8"	WASHER
AD-39	Washer - 1/2" x 1/4" x 1/8"	WASHER
AD-40	Washer - 1/2" x 1/4" x 1/8"	WASHER
AD-41	Washer - 1/2" x 1/4" x 1/8"	WASHER
AD-42	Washer - 1/2" x 1/4" x 1/8"	WASHER
AD-43	Washer - 1/2" x 1/4" x 1/8"	WASHER
AD-44	Washer - 1/2" x 1/4" x 1/8"	WASHER
AD-45	Washer - 1/2" x 1/4" x 1/8"	WASHER
AD-46	Washer - 1/2" x 1/4" x 1/8"	WASHER
AD-47	Washer - 1/2" x 1/4" x 1/8"	WASHER
AD-48	Washer - 1/2" x 1/4" x 1/8"	WASHER
AD-49	Washer - 1/2" x 1/4" x 1/8"	WASHER
AD-50	Washer - 1/2" x 1/4" x 1/8"	WASHER

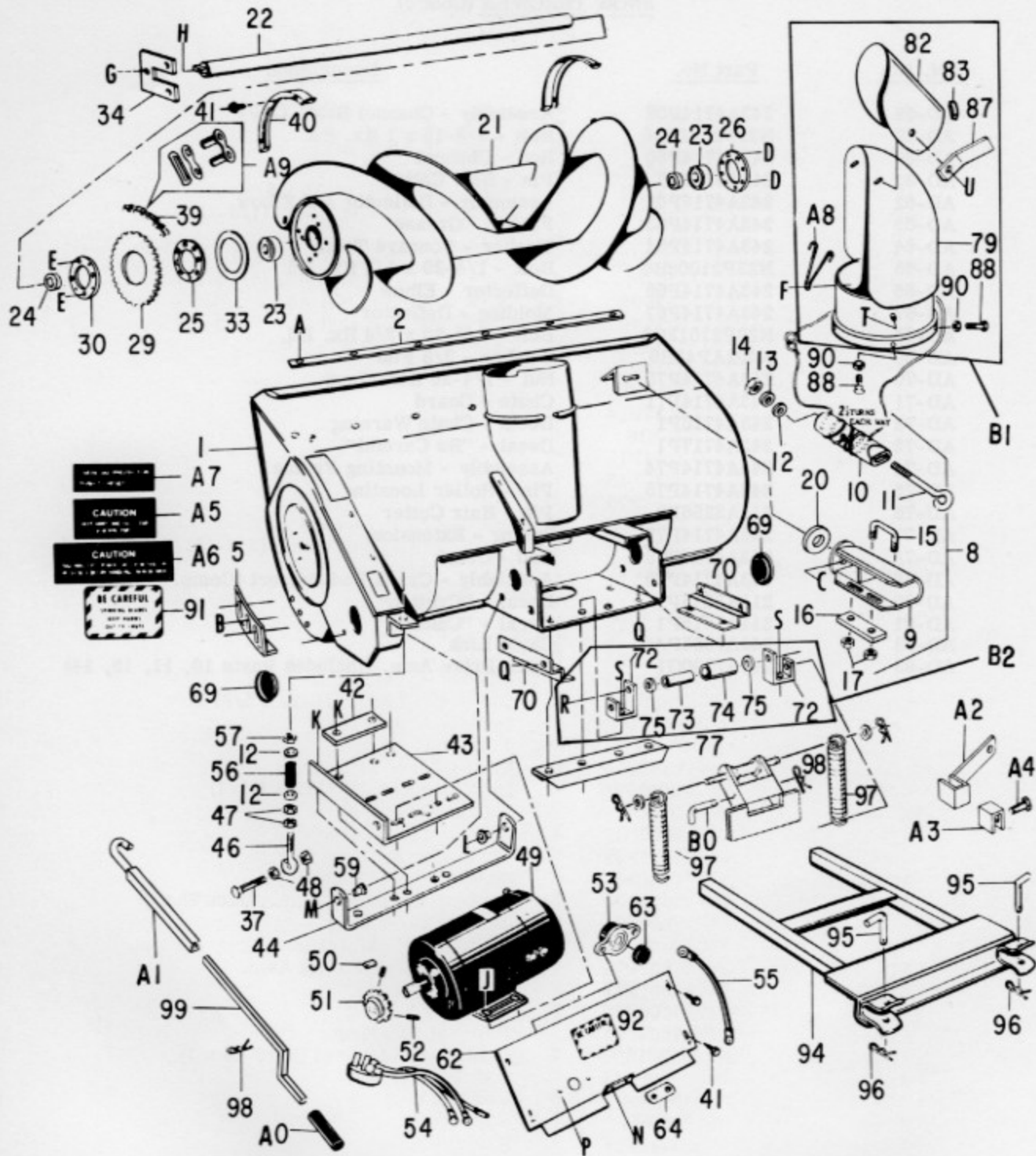

CAUTION  
 CAUTION  
 CAUTION  
 BE CAREFUL  
 (SMALL BLADES)  
 (SEE PARTS)  
 (SEE PARTS)

A	B	C	D	E	F	G	H	J	K	L	M	N	P	Q	R	S	T	U
3	6	18	27	31	88	35	37	6	45	58	61	93	65	71	76	78	81	6
4	7	19	28	32	80	28	38	38	12	12	12	4	68	12	12	12	80	85
			32				7	19	60	19		66		7	19			86
													67					

REFERENCE NUMBER IS THE NUMBER ON THE DRAWING PRECEDED BY "AD"

SNOW THROWER

Model AD42BA and AD42CA

<u>Ref. No.</u>	<u>Part No.</u>	<u>Description</u>
AD-1	244A7335P1	Header Housing Assembly
AD-2	243A4714P2	Blade, Scraper
AD-3	243A4714P3	Bolt, Carriage 1/4-20 x 5/8
AD-4	N238P21G6	Nut and Lockwasher Assembly 1/4-20
AD-5	178B8411P1	Skid Shoe
AD-6	N657P23012B6	Bolt, Carriage 5/16-18 x 3/4
AD-7	N256P23C6	Nut and Lockwasher Assembly 5/16-18
AD-8	244A7335P8	Stack Drive Bracket (Complete)
AD-9	244A7335P9	Stack Drive Bracket
AD-10	244A7335P10	Cable, Tube, and Sleeve Assembly
AD-11	243A4714P12	Eye Bolt, Drive Tube
AD-12	N402AP43B6	Washer, Plain 3/8
AD-13	243A4714P14	Washer, Spring
AD-14	N264P25B6	Locknut, Hex 3/8-16
AD-15	244A7335P15	U-Bolt, Level Wind
AD-16	244A7335P16	Strap, Friction
AD-17	243A4714P70	Locknut, Hex 1/4-20
AD-18	N657P25016B6	Bolt, Carriage 3/8-16 x 1
AD-19	N256P25C6	Nut and Lockwasher Assembly 3/8-16
AD-20	244A7335P20	Washer 13/32 x 1 1/2 x .060
AD-21*	244A7335P21	Auger Assembly (BA only)
AD-22	244A7335P22	Shaft, Auger
AD-23*	244A7335P23	Bearing, Auger (BA only)
AD-24*	244A7335P24	Collar, Bearing Locking (BA only)
AD-25*	244A7335P25	Bearing, Flange (Sprocket Side) (BA only)
AD-26	243A4714P20	Bearing, Flange
AD-27	N22P23010B6	Bolt, Hex Head (5/16-18 x 5/8)
AD-28	N405P42C6	Lockwasher 5/16
AD-29*	244A7335P29	Sprocket, Auger (BA only)
AD-30*	244A7335P30	Plate, Clutch Pressure (BA only)
AD-31*	244A7335P31	Bolt, Lock (BA only)
AD-32*	244A7335P32	Washer, Belleville (BA only)
AD-33*	244A7335P33	Washer, Thrust (BA only)
AD-34	244A7335P34	Plate, Auger Mounting
AD-35	N22P23008B6	Bolt, Hex Head 5/16-18 x 1/2
AD-36	244A7365P1	Washer, Plain 5/16 x 3/4 x .065
AD-37	N22P29020B6	Bolt, Hex Head 1/2-13 x 1 1/4
AD-38	N405P45C6	Lockwasher 1/2
AD-39	243A4714P31	Chain
AD-40	243A4714P32	Guard, Chain
AD-41	N154P2408C	Screw, Self-Tap 1/4-14 x 1/2
AD-42	244A7335P42	Plate, Motor Stop
AD-43	244A7335P43	Plate, Mounting
AD-44	244A7335P44	Bracket, Mounting
AD-45	N22P25020B6	Bolt, Hex Head 3/8-16 x 1 1/4
AD-46	243A4714P12	Eye Bolt
AD-47	N258P25B6	Nut, Hex 3/8-16
AD-48	N213P29B6	Nut, Hex Jam 1/2-13
AD-49	178B8170P1	Motor
AD-50	243A4714P36	Key
AD-51	243A4714P37	Sprocket, Motor
AD-52	243A4714P38	Set Screw
AD-53	244A7000P1	Circuit Breaker
AD-54	244A7171G1	Cord Assembly
AD-55	211A3556G8	Jumper Wire
AD-56	244A7335P56	Spring
AD-57	N264P25B6	Locknut, Hex 3/8-16
AD-58	N22P25024B6	Bolt, Hex Head 3/8-16 x 1 1/2

<u>Req. No.</u>	<u>Part No.</u>	<u>Description</u>
AD-59	244A7335P59	Spacer, Tie Strap
AD-60	N405P43C6	Lockwasher 3/8
AD-61	N22P25020B6	Bolt, Hex Head 3/8-16 x 1 1/4
AD-62	244A7335P62	Plate, Motor Cover
AD-63	244A7335P63	Plug, Button
AD-64	247A7366P1	Clamp
AD-65	N37P17016B6	Screw, Machine 10-24 x 1
AD-66	N213P23B6	Nut, Hex Jam 5/16-18
AD-67	N210P17B6	Nut, Hex 10-24
AD-68	N405P39C6	Lockwasher #10
AD-69	243A4714P57	Plug, Button
AD-70	244A7335P70	Channel Bracket Assembly
AD-71	N22P25016B6	Bolt, Hex Head 3/8-16 x 1
AD-72	244A7335P72	Bracket, Lift Mounting
AD-73	244A7335P73	Spacer, Lift Mounting
AD-74	244A7335P74	Spacer, Lift Mounting
AD-75	244A7365P3	Washer, Plain 17/32 x 1 1/16 x .095
AD-76	N22P23056B6	Bolt, Hex Head 5/16-18 x 3 1/2
AD-77	244A7335P77	Channel Reinforcement
AD-78	N657P25016B6	Bolt, Carriage 3/8-16 x 1
AD-79*	244A7335P79	Elbow and Pivot Assembly (BA only)
AD-80	243A4714P64	Washer, Concave Tooth
AD-81	N22P21008B6	Bolt, Hex Head 1/4-20 x 1/2
AD-82*	244A7335P82	Deflector, Elbow (BA only)
AD-83	243A4714P67	Pad Deflector
AD-85	N403P50C6	Lockwasher, External Tooth 1/2
AD-86	244A7365P2	Washer, Plain 3/8 x 7/8 x .083
AD-87	244A7335P87	Strap, Locking
AD-88	N22P21010B6	Bolt, Hex Head 1/4-20 x 5/8
AD-89	243A4714P70	Locknut, Hex 1/4-20
AD-90	N405P41C6	Lockwasher 1/4
AD-91	243A4716P1	Decal, "Chute Warning..."
AD-92	243A4717P1	Decal, "Be Careful..."
AD-93	N22P21016B6	Bolt, Hex Head 1/4-20 x 1
AD-94	244A7335P94	Mounting Frame Assembly
AD-95	243A4714P75	Pin, Roller Locating
AD-96	211A3256P2	Cotter, Hairpin
AD-97	243A4714P77	Spring, Extension
AD-98	211A3256P2	Cotter, Hairpin
AD-99	244A7335P99	Rod, Crank
AD-A0	244A7335PA0	Grip, Handle
AD-A1	244A7335PA1	Crank Rod, Extension Assembly
AD-A2	244A7335PA2	Bracket, Mounting
AD-A3	244A7335PA3	Clip, Back-Up
AD-A4	N22P23016B6	Bolt, Hex Head 5/16-18 x 1
AD-A5	211A3515P1	Decal, Caution
AD-A6	211A3516P1	Decal, Caution
AD-A7	243A4937P1	Decal, Circuit Breaker
AD-A8	244A7335PA8	Chute Guard
AD-A9	244A7335PA9	Link Chain
AD-B0	244A7335PB0	Pin, Lift Strap Mounting
AD-21	244A7335PB1	Auger Assembly (CA only)
AD-29	244A7335PB3	Sprocket (CA only)
AD-23	243A4714P19	Auger Bearing (CA only)
AD-79	158C9013G1	Elbow & Pivot Assembly (CA only)
AD-82	127D8075P1	Deflector (CA only)
AD-24	243A4714P27	Washer (CA only)
AD-B1	158C9023G1	Chute & Deflector Assembly (BA only)
AD-B1	158C9023G2	Chute & Deflector Assembly (CA only)
AD-B2	247A7791G1	Lift Mounting Asm. (Includes Parts #72, 73, 74, 75, 76, 78)

**BE CAREFUL**  
SPINNING BLADES  
KEEP HANDS  
OUT OF CHUTE

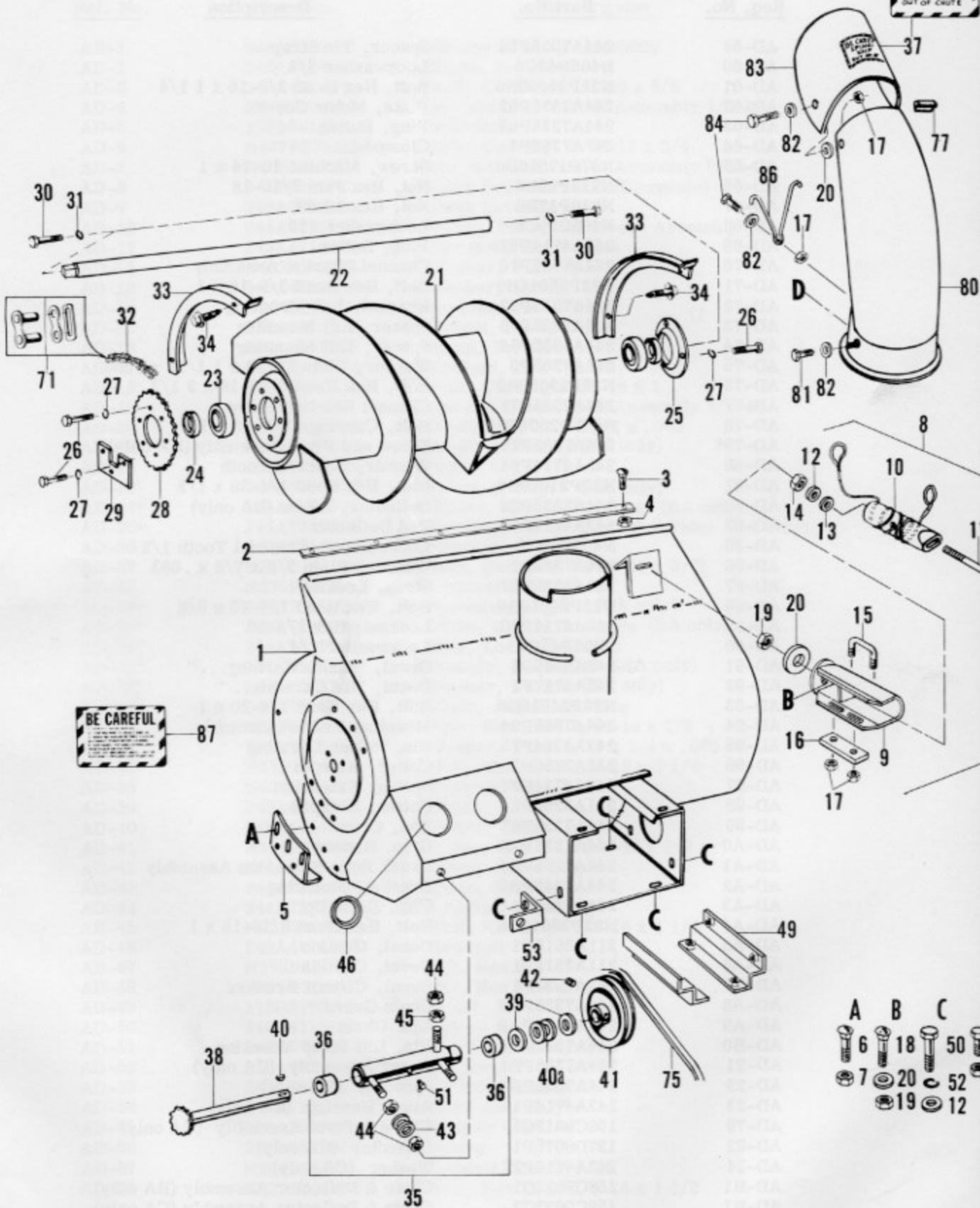

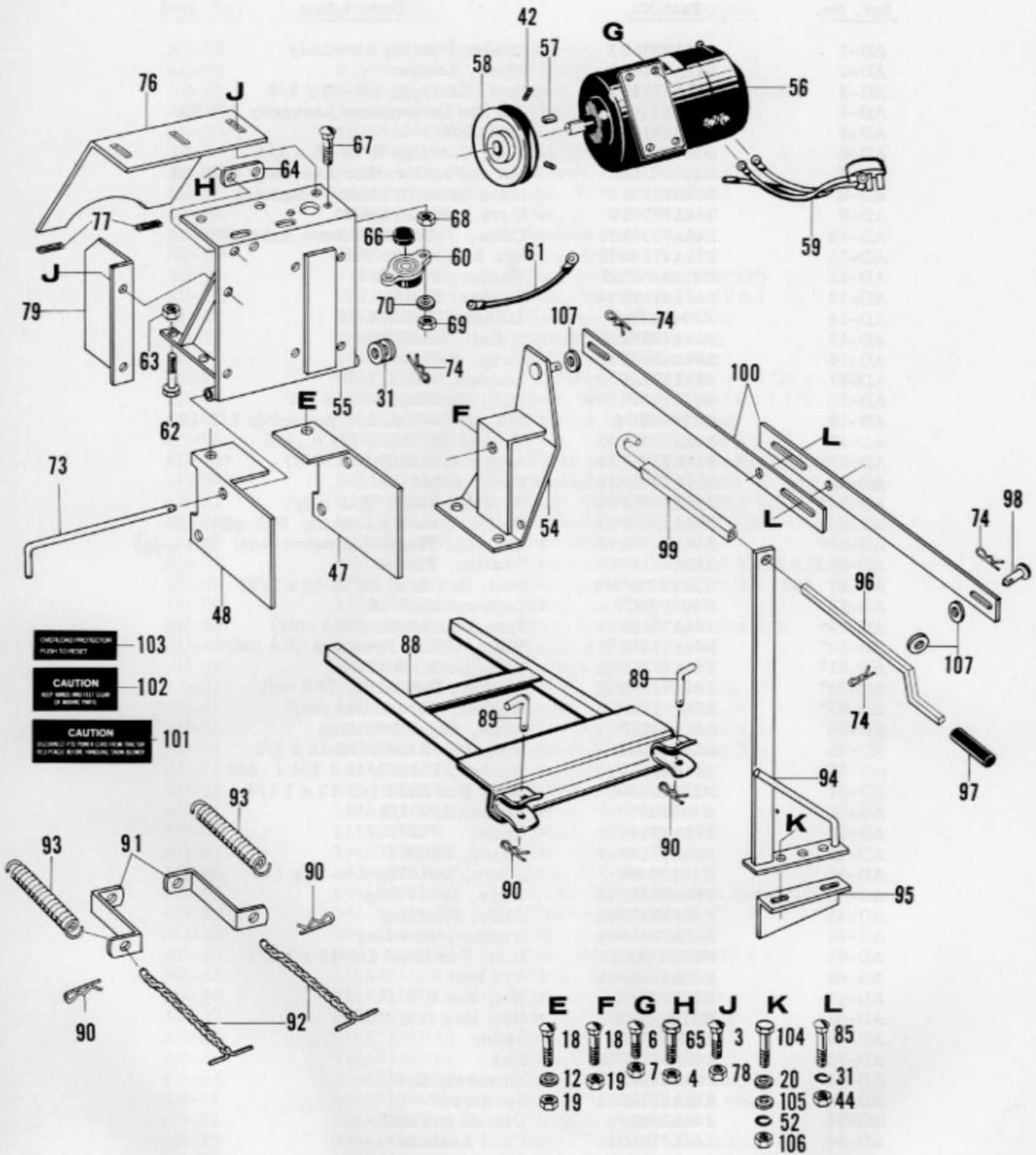

SNOW THROWER

Model AD38AA

<u>Ref. No.</u>	<u>Part No.</u>	<u>Description</u>
AD-1	127D8083G1	Header Housing Asm.
AD-2	247A7606P2	Scraper Blade
AD-3	243A4714P3	Carriage Bolt (1/4-20 x 5/8)
AD-4	N238P21C6	Nut & Lockwasher Asm. (1/4-20)
AD-5	178B8411P1	Shoe - Skip
AD-6	N657P23012B6	Carriage Bolt (5/16-18 x 3/4)
AD-7	N256P23C6	Nut & Lockwasher Asm. (5/16-18)
AD-8	244A7335P8	Stack Drive Bracket Asm.
AD-9	244A7335P9	Stack Drive Bracket
AD-10	244A7335P10	Cable Tube & Sleeve Asm.
AD-11	243A4714P12	Eye Bolt
AD-12	N402AP43B6	Flat Washer
AD-13	243A4714P14	Spring Washer
AD-14	N264P25B6	Lock Nut 3/8 - 16
AD-15	244A7335P15	U-Bolt
AD-16	244A7335P16	Strap Friction
AD-17	243A4714P70	Lock Nut
AD-18	N657P25016B6	Carriage Bolt (3/8-16 x 1)
AD-19	N256P25C6	Nut & Lockwasher Asm. (3/8-16)
AD-20	244A7335P20	Flat Washer
AD-21	247A7606P21	Auger Asm.
AD-22	247A7606P22	Auger Shaft
AD-23	244A7335P23	Auger Bearing
AD-24	244A7335P24	Collar Bearing Locking
AD-25	243A4714P20	Flanged Bearing
AD-26	N22P23010B6	Hex-Head Bolt (5/16-18 x 5/8)
AD-27	N405P42C6	Lockwasher (5/16)
AD-28	247A7606P28	Sprocket, Auger
AD-29	244A7335P34	Plate, Auger Mounting
AD-30	N22P29020B6	Hex Head Bolt (1/2-13 x 1 1/4)
AD-31	N405P45C6	Lockwasher (1/2)
AD-32	247A7606P32	Chain, Auger Drive
AD-33	243A4714P32	Chain Guard
AD-34	N154P2408C	Screw, Washer Head
AD-35	247A7606P35	Housing & Bushing Asm., Jack Shaft
AD-36	247A7606P36	Jack Shaft Bushing
AD-37	243A4716P1	Decal, Chute Warning
AD-38	247A7606P38	Jack Shaft & Sprocket Asm.
AD-39	247A7606P39	Flat Washer
AD-40	247A7606P40	Woodruff Key
AD-41	247A7606P41	Pulley & Hub Asm.
AD-42	N22P23016B6	Screw, Square Head (5/16-18 x 1)
AD-43	247A7606P43	Flat Washer
AD-44	N203P29B6	Hex Nut (1/2-13)
AD-45	N213P29B6	Nut, Half Hex (1/2-13)
AD-46	243A4714P57	Button Plug
AD-47	247A7397P2	Motor Mounting Brkt. (RH)
AD-48	247A7397P1	Motor Mounting Brkt. (LH)
AD-49	244A7335P70	Channel Brkt. Asm.
AD-50	N22P25020B6	Hex Head Bolt (3/8-16 x 1 1/4)
AD-51	243A4714P63	Fitting, Grease
AD-52	N405P43C6	Lockwasher (3/8)
AD-53	247A7606P53	Chain Anchor Brkt.
AD-54	247A7338P1	Lift Bracket Asm.
AD-55	247A7606P55	Motor Mounting Plate Asm.
AD-56	178B8170P1	Motor
AD-57	243A4714P36	Key



SNOW THROWER (Cont'd)

<u>Ref. No.</u>	<u>Part No.</u>	<u>Description</u>
AD-58	247A7391P1	Pulley & Hub Asm.
AD-59	247A7334G1	Cord Asm.
AD-60	244A7000P1	Circuit Breaker
AD-61	178B8299G1	Jumper Wire
AD-62	N22P25032B6	Hex Head Bolt (3/8-16 x 2)
AD-63	N258P25B6	Hex Nut (3/8-16)
AD-64	243A4714P49	Lift Rod Clamp
AD-65	N22P21016B6	Hex Head Bolt (1/4-20 x 1)
AD-66	244A7335P63	Button, Plug
AD-67	N37P17016B6	Machine Screw (10-24 x 1)
AD-68	N213P23B6	Nut, Half Hex (5/16-18)
AD-69	N210P17B6	Hex Nut (10-24)
AD-70	N405P9C6	Lockwasher (#10)
AD-71	244A7335PA9	Master Link Repair Kit
AD-72		
AD-73	247A7398P1	Pin Locating
AD-74	211A3256P2	Hair Pin Cotter
AD-75	247A7606P75	V-Belt
AD-76	247A7402G1	Motor Cover
AD-77	243A4714P67	Deflector Molding
AD-78	247A7606P78	Wing Nut (1/4-20)
AD-79	178B8410P1	Cover Pulley
AD-80	247A7606P80	Deflector & Elbow Asm.
AD-81	N22P21008B6	Hex Head Bolt (1/4-20 x 1/2)
AD-82	243A4714P64	Washer Concave Tooth
AD-83	247A7606P83	Elbow Deflector
AD-84	N22P21012B6	Hex Head Bolt (1/4-20 x 3/4)
AD-85	N62P29020B6	Carriage Bolt(1/2-13 x 1 1/4)
AD-86	247A7606P86	Lift Spring Hook
AD-87	243A4717P1	Decal "Be Careful"
AD-88	158C9015G1	Mounting Frame Asm.
AD-89	243A4714P75	Roller Locating Pin
AD-90	211A3256P2	Hair Pin Cotter
AD-91	247A7606P91	Chain Anchor Bracket
AD-92	247A7606P92	Chain & Toggle Asm.
AD-93	247A7606P93	Lift Spring
AD-94	178B8405G1	Crank Rod Support
AD-95	178B8407P1	Lower Mounting Brkt.
AD-96	244A7335P99	Crank
AD-97	244A7335PA0	Handle Grip
AD-98	211A3505P20	Clevis Pin 1/2 x 1 3/4
AD-99	244A7335PA1	Crank Extension
AD-A1	247A7541P1	Lift Bar
AD-A2	211A3515P1	Decal Caution
AD-A3	211A3516P1	Decal Caution
AD-A4	243A4937P1	Decal Circuit Breaker
AD-A5	N22P23020B6	Bolt, Hex Head (5/16-18 x 1 1/4)
AD-A6	247A7606A6	Flat Washer
AD-A7	N210P23B6	Hex Nut (5/16-18)
AD-A8	247A7606A8	Flat Washer

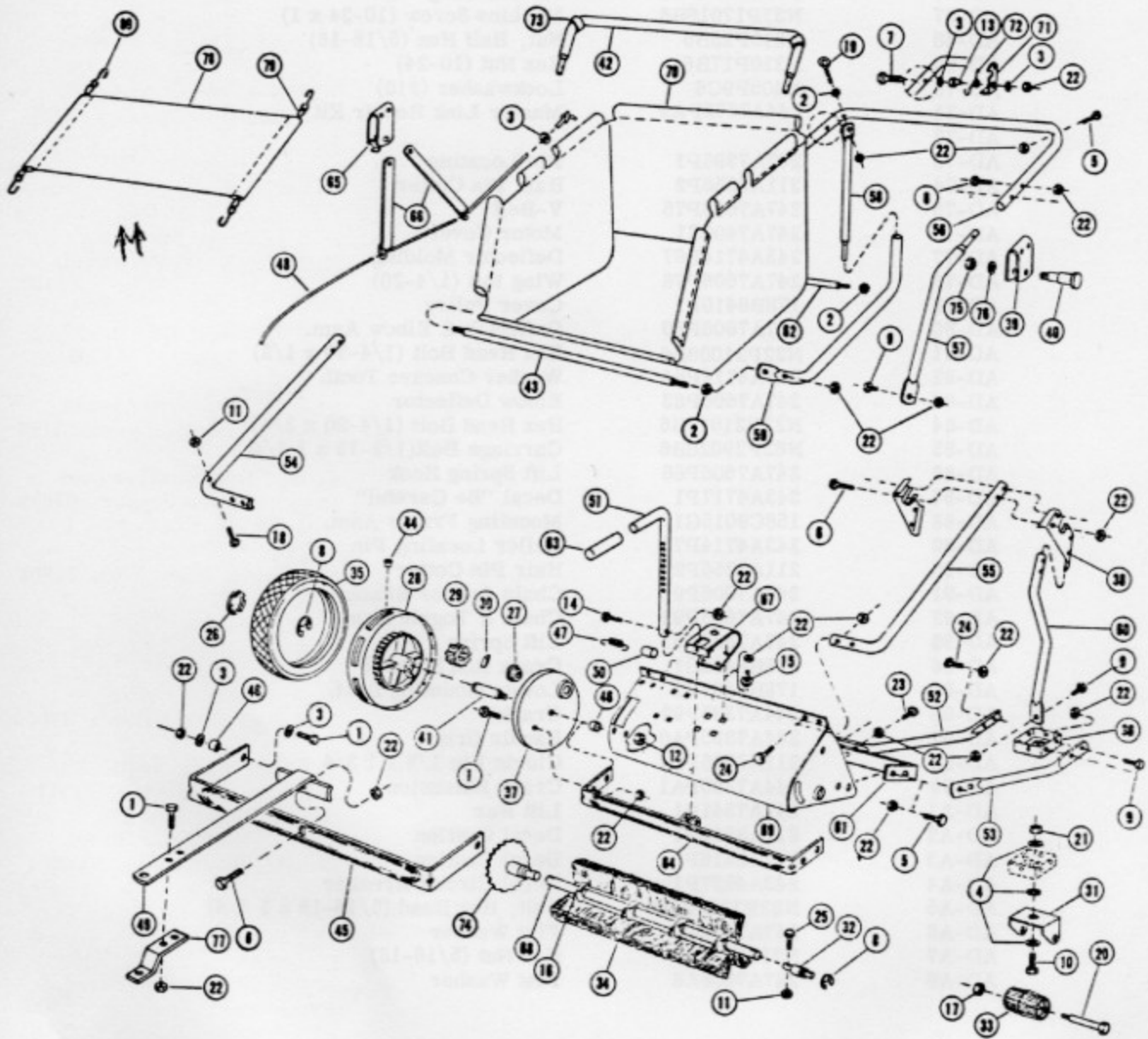

TRAILING LAWN SWEEPER

Model AS 31

General Electric Elec-Trak tractor dealers should contact closest Lambert parts distributor to obtain replacement parts for AS 31.

When ordering parts, always specify model number, part number and description. Send your order direct to:

<u>State</u>	<u>Distributor</u>	<u>Address</u>
California	Tarzana Mower & Engine Parts, Inc.	6075 Reseda Boulevard Reseda, California 91335
Colorado	South Denver Auto Parts & Service	527 West Evans Denver, Colorado 80223
Illinois	Bob's Garden Center	9641 West Grand Avenue Franklin Park, Illinois 60131
Massachusetts	Morton B. Collins Co.	300 Birnie Avenue Springfield, Massachusetts 01107
Michigan	Wilson's Hardware & Lawn Supplies	1285 W. Eight Mile Road Detroit, Michigan 48203
Minnesota	Ed McDevitt Company	3387-93 Brownlow Avenue Minneapolis, Minnesota 55426
New Jersey	Feld Distributors	67 East Ridgewood Avenue Paramus, New Jersey 07652
New York	W. J. Norton's Service, Inc.	359 Court Street Binghamton, New York 13904
Pennsylvania	Scranton Auto Ignition Co.	1133 Wyoming Avenue Scranton, Pennsylvania 18500
Utah	A-1 Engine & Mower Co.	437 East Ninth, South Salt Lake City, Utah 84111
Washington	Bailey Rebuild, Inc.	1325 East Madison Street Seattle, Washington 98122
Wisconsin	Bill's Hardware, Inc.	13885 West Capitol Drive Brookfield, Wisconsin 53005
Canada	Suntester Equipment, Ltd.	915 Oxford Street Toronto, Ontario

TRAILING LAWN SWEEPER

Model AS 31

<u>Ref. No.</u>	<u>Part No.</u>	<u>Description</u>
AS-1	L-59	5/16-18 x 3/4 Hex Cap Screw
AS-2	L-60	5/16-18 Hex Nut
AS-3	L-99	5/16" S.A.E. Flat Washer
AS-4	L-64A	1/2" S.A.E. Flat Washer
AS-5	L-80	5/16-18 x 1 Hex Cap Screw
AS-6	L-81	5/16-18 x 1 1/4 Hex Cap Screw
AS-7	L-127	5/16-18 x 1 1/2 Hex Cap Screw
AS-8	L-262	5/8" E-Type Ret. Ring
AS-9	L-279	5/16-18 x 1/2 Hex Cap Screw
AS-10	X-1258	1/2-13 x 1 1/4 Hex Cap Screw
AS-11	L-303	1/4-20 Lock Nut
AS-12	L-5486M	3/9-24 Lock Nut (Spec.)
AS-13	L-5552	5/16-18 Pilot Nut (Spec.)
AS-14	X-1027	5/16-18 x 1 3/4 Hex Cap Screw
AS-15	X-1042	5/16-18 x 5/8 Carr. Bolt (Spec.)
AS-16	X-1043	Brush Holder Spring
AS-17	X-1127	3/8-24 Lock Nut
AS-18	X-1234	1/4-20 x 1 Eye Bolt
AS-19	X-1235	5/16-18 x 2 3/4 Eye Bolt
AS-20	X-1293	Caster Stud
AS-21	X-1353	1/2-13 Lock Nut
AS-22	X-1107	5/15-18 Lock Nut
AS-23	X-1358	5/16-18 x 1 1/4 Tube Bolt
AS-24	X-1359	5/16-18 x 1 Tube Bolt
AS-25	X-2020	1/4-20 x 1 Hex Cap Screw
AS-26	L-5471B	Hub Cap
AS-27	L-5497A	Freeway Bearing
AS-28	L-5750A	Die Cast Wheel Assembly
AS-29	L-5753H	Pinion Gear
AS-30	L-5761H	Pinion Pawl
AS-31	1-1640	Caster Bracket
AS-32	1-1179	Brush Stud Axle
AS-33	1-1633	Caster Roller
AS-34	1-1421	Brush Strip
AS-35	1-1637	10 x 2.25 Tire
AS-36	1A-1638	Caster Plate Assembly
AS-37	1-1428	Wheel Shield
AS-38	1-1429	Frame Pivot Bracket
AS-39	1-1430	Pivot Bracket
AS-40	1-1443	Pivot Pin
AS-41	1-1444	Wheel Stud
AS-42	1-1454	Pivot Stand Tube
AS-43	1-1455	Hamper Tie Rod
AS-44	L-288	Oiler
AS-45	1-1817	"U" Bar
AS-46	1-1458	Spacer (Axle)
AS-46	1-1526	Spacer (Hitch)
AS-47	1-1465	Adjustment Spring
AS-48	1-1467	Dump Rope
AS-49	1A-1782	Hitch Tongue
AS-50	1-1474	Retainer Tube
AS-51	1-1479	Adjustment Tube
AS-52	1-1601	Pivot Stand Brace
AS-53	1-1825	Pivot Stand Brace
AS-54	1-1488	Pivot Stand Tube R.

TRAILING LAWN SWEEPER (Continued)

Model AS 31

<u>Ref. No.</u>	<u>Part No.</u>	<u>Description</u>
AS-55	1-1489	Pivot Stand Tube L.
AS-56	1-1493	Top Hamper Tube
AS-57	1-1495	Side Hamper Tube
AS-58	1-1496	Hamper Tube
AS-59	1-1497	Bottom Tube
AS-60	1-1602	Pivot Support R.
AS-60	1-1603	Pivot Support L.
AS-61	1-1770	Stiffener
AS-62	1-1519	Rear Hamper Rod
AS-63	1-1522B	Handle Grip
AS-64	1A-1780	Bumper Assembly
AS-65	1A-1484	Bracket Assembly
AS-66	1A-1440	Lever Assembly
AS-67	1A-1823	Adjustment Bracket
AS-68	1A-1419	Brush Axle Assembly
AS-69	1A-1791	Shield Assembly
AS-70	1A-1818	Hamper Assembly
AS-71	1-1537	Hamper Latch
AS-72	1-1538	Latch Spring
AS-73	1-1604	Rubber Sleeve
AS-74	1A-1408	Drive Sprocket Assembly
AS-75	X-1126	3/8-24 Hex Nut
AS-76	X-1070	3/8" Lock Washer
AS-77	1-1553	Hitch Pin Bracket
AS-78	1A-1562	Wind Apron
AS-79	1A-1605	Stretch Cord
AS-80	X-1361	Cord Hook

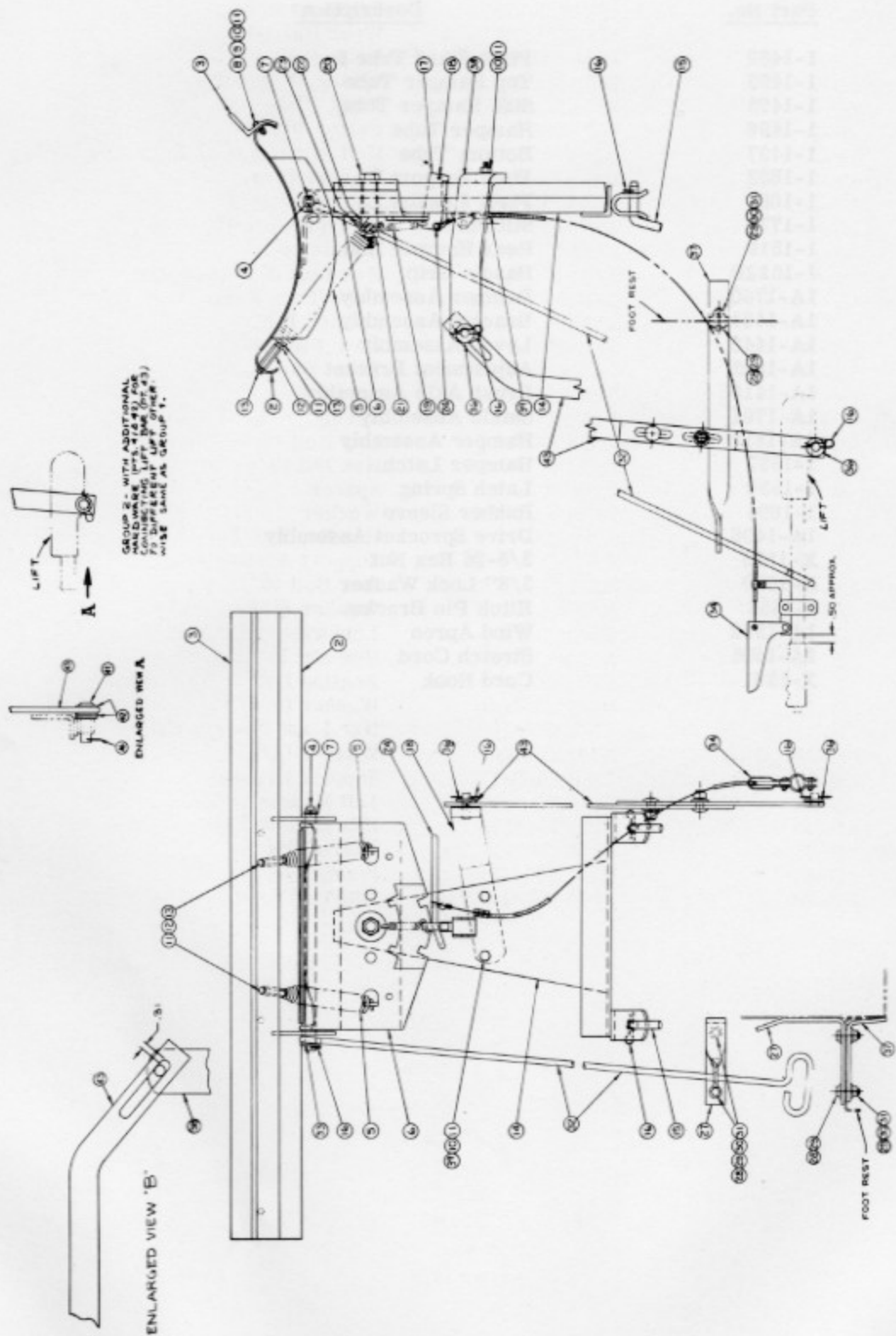

42" SNOW/DOZER BLADE

<u>Ref. No.</u>	<u>Part No.</u>	<u>Description</u>
AB-2	243A4890G2	Blade Asm.
AB-3	178B8059P2	Wear Bar
AB-4	243A4891P2	Pivot Rod
AB-5	243A4892P1	Spring, Blade Trip
AB-6	243A4893G1	Pivot Plate Asm.
AB-7	N503P1520B6	Cotter Pin
AB-8	N62P25016B6	Bolt, Carriage (3/8-16 x 1)
AB-9	N402AP43B6	Washer (3/8)
AB-10	N405P13C6	Lockwasher (3/8)
AB-11	N258P25B6	Hex Nut (3/8-16)
AB-12	243A4894P1	Coupler Nut
AB-13	N22P25024B6	Hex Bolt (3/8-16 x 1.5)
AB-14	155C8009G2	Push Tube Asm.
AB-15	243A4895P1	Drilled Pin
AB-16	243A4543P1	Hair Pin Cotter
AB-17	243A4896P1	Pivot Bar Lock
AB-18	N533P2516B	Spring Pin
AB-19	243A4897P1	Spring, Angle Lock
AB-20	N22P35072B6	Hex Bolt (3/4-10 x 4.50)
AB-21	N213P35B6	Hex Nut (3/4-10)
AB-22	243A4898P1	Spacer
AB-23	243A4899P1	Washer
AB-24	178B8081P1	Handle, Bar Lock
AB-27	178B8259P1	Support Angling Rod
AB-28	N22P23018B6	Hex Bolt (5/16-18 x 1 1/8)
AB-29	N402AP72B6	Washer (5/16)
AB-30	N405P12C6	Lockwasher (5/16)
AB-31	N210P23B6	Hex Nut (5/16-18)
AB-32	178B8255P1	Angling Rod
AB-33	N402AP48B6	Washer (3/4)
AB-34	178B8268G1	Bar Lock Release Cable
AB-36	N402AP45B6	Washer (1/2)
AB-37	178B8287P1	Support Bracket
AB-38	247A7384G1	Lift Bracket Asm.
AB-39	N22P25052B6	Hex Bolt (3/8-16 x 3.25)
AB-41	211A3505P20	Clevis Pin
AB-42	N402AP15B6	Washer (1/2)
AB-43	178B8463G1	Lift Bar Asm.

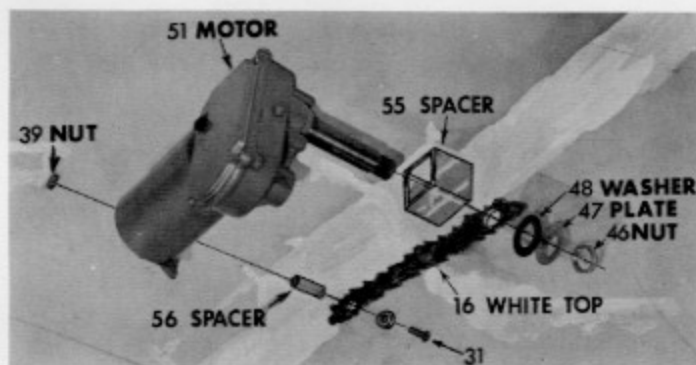
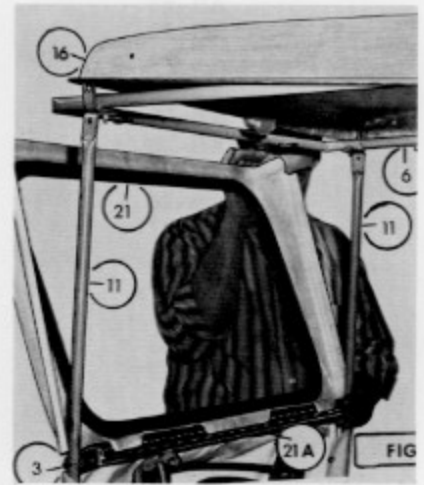
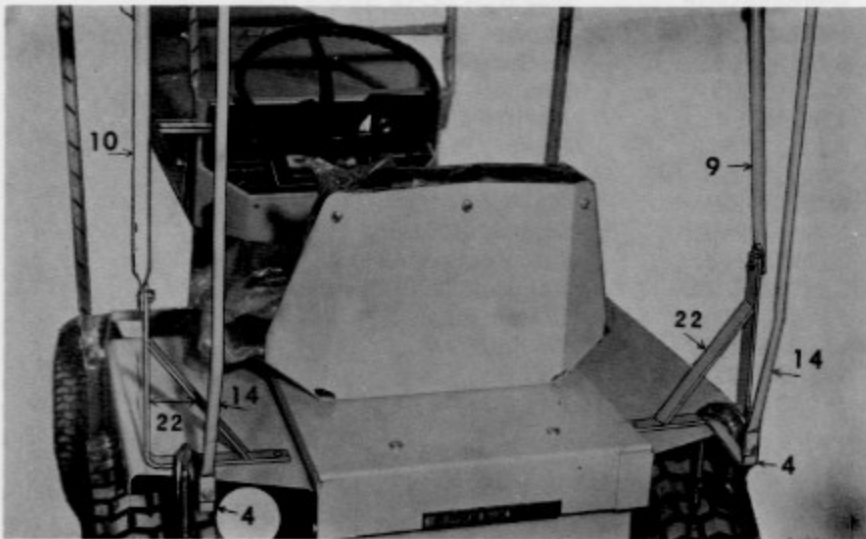
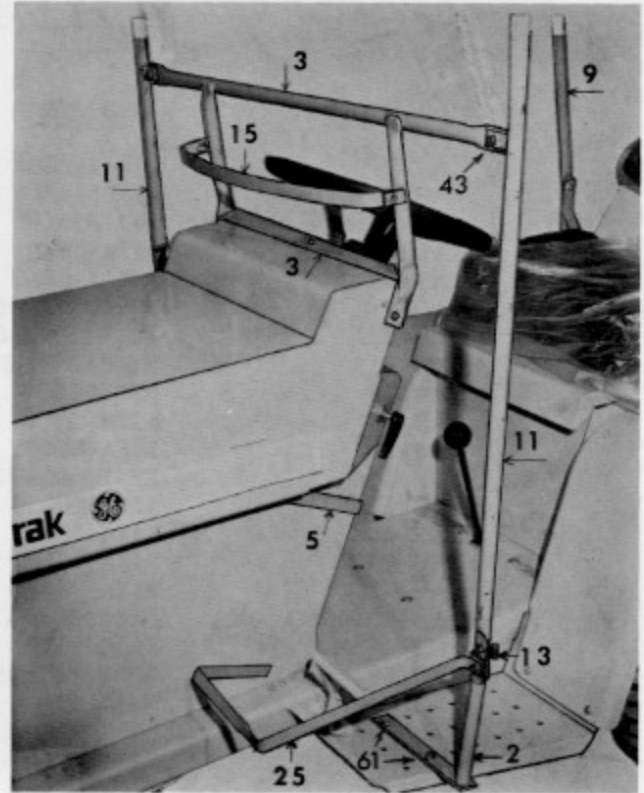
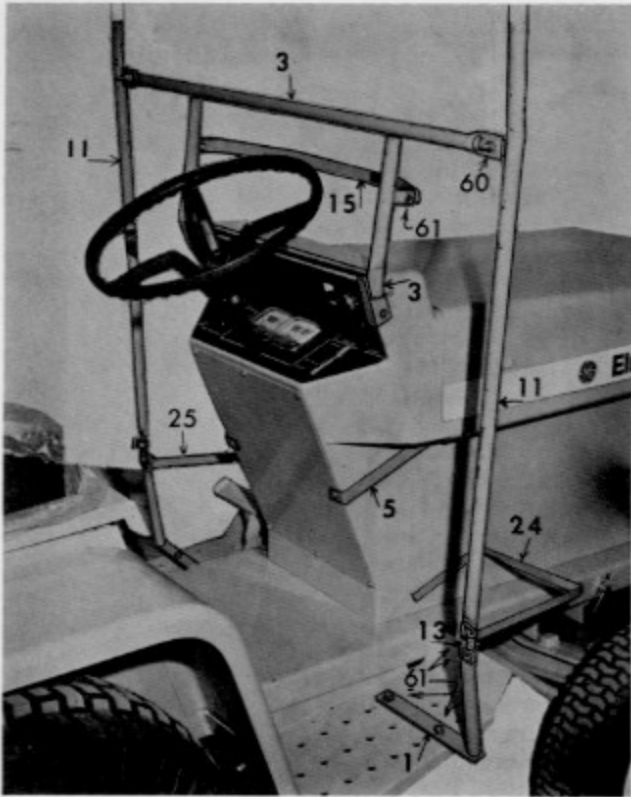

CAB

AG56

When ordering parts, always include part number and full description.  
Send orders direct to: Original Cab  
Arlington, Indiana 46104

Or call (317) 663-2214

Refer to Assembly Instructions for Part Location

<u>Ref. No.</u>	<u>Part No.</u>	<u>Description</u>
1	6140	Foot - Right Hand
2	6407	Foot - Left Hand
3	6141	Front Panel Frame
4	6142	Rear Curtain Boxing Post Extension - Lower
5	6086	Vinyl Holder
6	5648	Top Frame
9	3071	Rear Corner Post - Right Hand
10	3072	Rear Corner Post - Left Hand
11	2506	Front Corner Post - Right and Left Hand (Std. Bent)
14	5706	Rear Curtain Boxing Post - Right and Left Hand
15	6143	Vinyl Support
16	5551	Fiberglass Top (Large/White)
17	6098	Door - Right Hand
18	6099	Door - Left Hand
19	6144	Front Panel - Vinyl
20	6145	Rear Curtain - Vinyl
21	5975	Windshield
21A	5976	Windshield Zipper Strip
22	6146	Rear Mounting Bracket - Right and Left Hand
24	6082	Foot Pocket Guard - Right Hand
25	6083	Foot Pocket Guard - Left Hand
46	6409	Wiper Stud Nut
47	6410	Wiper Stud Plate
48	6411	Wiper Stud Washer
51	5766	Windshield Wiper Motor (Long Stem)
52	5674	12" Wiper Blade
53	5673	Adjustable Wiper Arm
54	6272	6' Section 2 Conductor Wire
59	6276	Template (Form WLT)
	6412	Parts Bag (Contents Listed Below)
-----		
13	15	Door Hinge
31	6061	#10-32 x 1 1/2" Round Head Machine Screw
39	3619	#10-32 Kep Nut
40	5578	#10 (7/32") Flat Washer
41	784	5/16"-18 x 3/4" Hex. Head Bolt
42	729	5/16"-18 Nut - Lock
43	926	1/4"-20 x 1" Hex. Head Bolt
44	3951	1/4" Flat Washer (S. A. E.)
45	6408	Wire Connector
55	6270	1" Square x 1" Long Spacer
56	6271	1/2" dia. x 1" Long Spacer
57	3702	Wiring Clip
60	730	1/4"-20 Nut - Lock
61	788	1/4"-20 x 3/4" Hex. Head Bolt

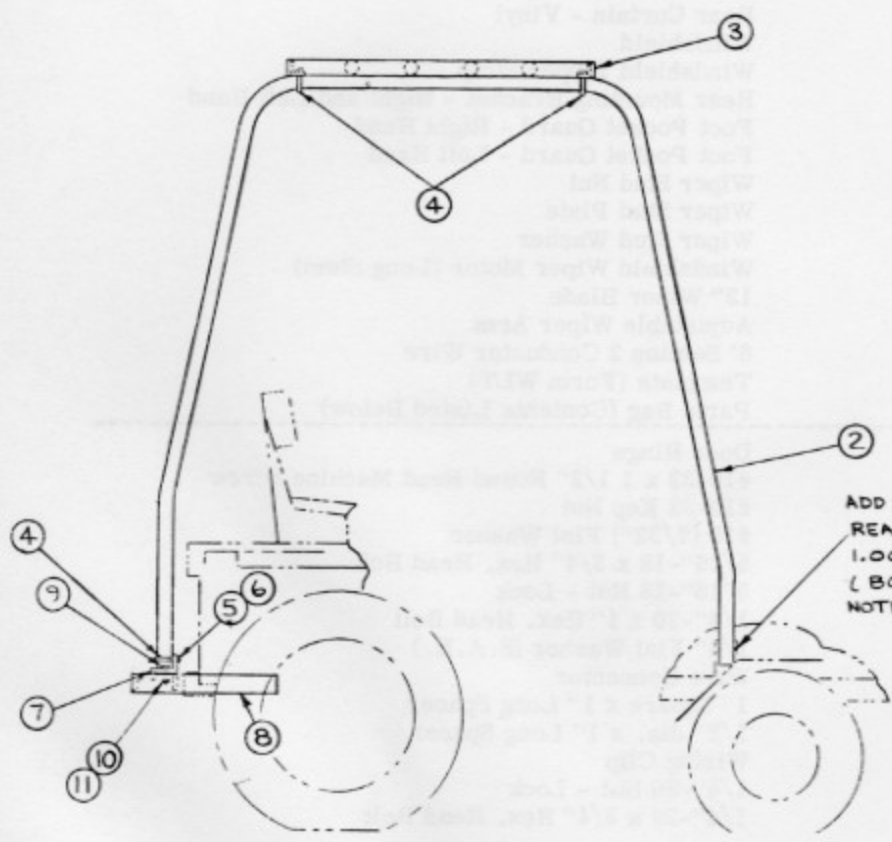
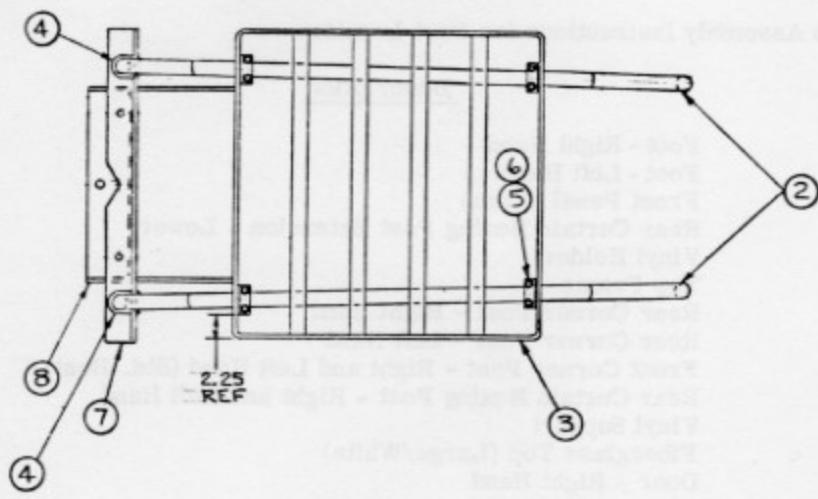

ADD SPACER TO MOUNTING TUBE WHEN USING  
 REAR AUX. POWER PACK (APB4)  
 1.00 NOM. DIA. PIPE X 3.00LG  
 (BOTH SIDES)  
 NOTE: USER WILL SUPPLY SPACERS

OVERHEAD GUARD

CF66

<u>Ref. No.</u>	<u>Part No.</u>	<u>Description</u>
2	191B4505P1	Frame (Left or Right)
3	158C9065G1	Overhead Guard
4	247A7565P1	U-Bolt
5	*N405P12B6	Lockwasher, Spring - 5/16 In.
6	*N210P23B6	Nut, Hex. - 5/16-18
7	247A7548P1	Support - Rear
8	178B8065G2	Hitch Adaptor
9	*N22P25016B6	Bolt, Hex. Hd. - 3/8-16 x 1 In.
10	*N258P25B	Nut, Hex. - 3/8-16
11	*N405P13B6	Lockwasher, Spring - 3/8 In.

\*Purchase small quantities locally.

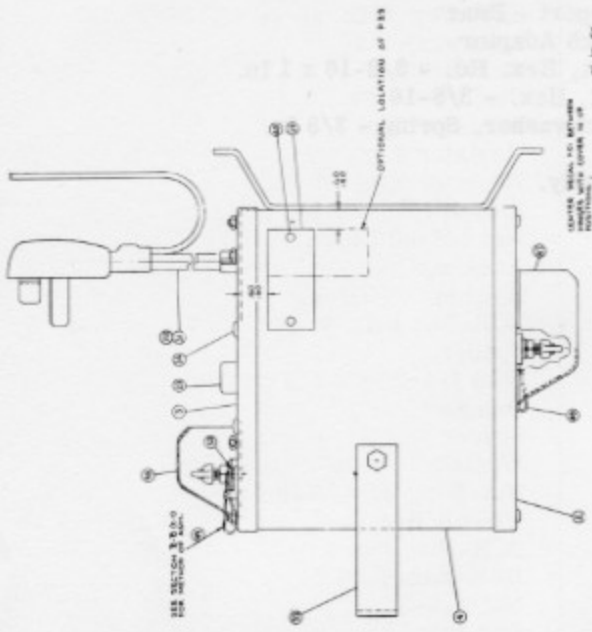
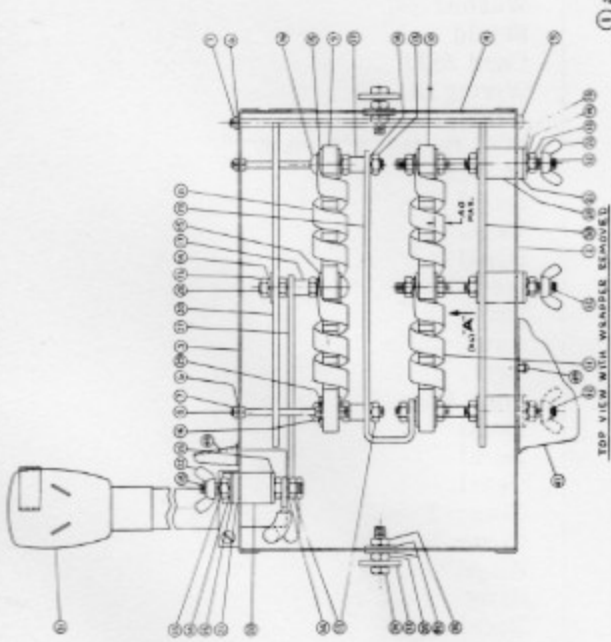

1 Z6AP30AA  
2 Z6AP70BA

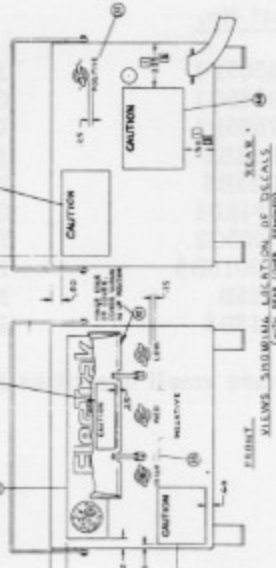
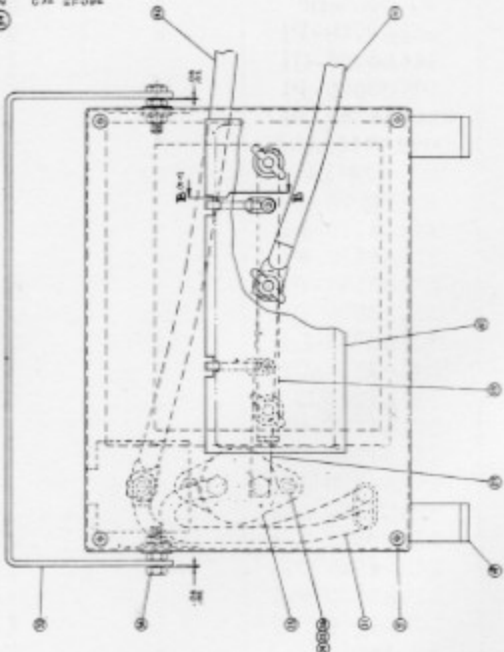

SEAL -  
WITH NEW O-RING (SEE NOTE)

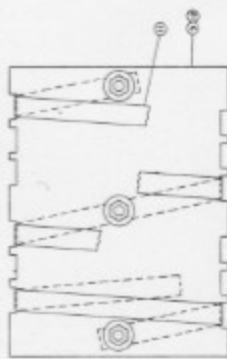

VIEW AT ARROW A LOOKING TOWARD  
MIDDLE OF WINDER MODEL ALIGNED TO  
IN FLUORIN SUPPLY TO 1.1.1.1.1.

WELDER  
Model AP90

Ref. No.	Part No.	Model		Description
		AP90BA	AP90AA	
1	26AP90AA		1	Assembly
2	541C962-P1	1	1	Panel
3	541C962-P2	1	1	Panel
4	541C963-G1	1	1	ASM-Wrapper
5	N80P15113B6	4	4	SCR-Pan PHL #8-32 x 7 1/16 Lg.
6	N405PBC6	8	8	Lockwasher #8
7	N210P15B6	12	12	Nut #8-32
8	N89P15046B6	2	2	Stud #8-32 x 2 7/8 Lg.
9	163B9907-P2	1	1	Resistor Supt
10	163B9907-P1	1	1	Resistor Supt
11	211A3213-P1	4	4	Resistor Ribbion
12	N90P21064	3	3	Stud 1/4-20 x 4 Brass
13	N250P21	22	22	Nut 1/4-20 Brass
14	N405P11C6	15	15	Lockwasher
15	N401P41	25	25	Washer 1/4 Brass
16	N81P21026	2	2	SCR-Pan PHL 1/4-20 x 15/8 Brass
17	243A4550- P7	3	3	Spacer
18	N90P21040	1	1	Stud 1/4-20 x 2 1/2 Brass
19	163B9983-P1	1	1	Bus Bar
20	211A3212-P1	4	4	Spacer
21	211A3212-P2	4	4	Washer
22	N237P21	4	4	Nut-Wing 1/4-20 Brass
23	243A4606-P2	1	1	Circuit Breaker
24	N80P16016B6	2	2	SCR-Pan PHL #10-32 x 1"
25	N405P9C6	2	2	Lockwasher #10
26	N210P16B6	2	2	Nut #10-32
27	243A4747-P1	1	1	Bus Bar
28	N81P21032	1	1	SCR-Pan PHL 1/4-20 x 2 Brass
29	N402AP8B6	4	4	Washer #8
30	163B9989-P1	2	2	Shield
31	243A4766-G1		1	Cord ASM
32	163B9990-P1	X	X	Wiring Diag.
33	243A4749-P1	1	1	Handle
34	N22P21016B6	2	2	SCR-Hx Hd 1/4-20 X 1"
35	N264P21B6	4	4	Nut-Lock 1/4-20
36	163B9988-P1	1	1	Decal
37	243A4745-P1	1	1	Decal
38	243A4745-P2	1	1	Decal
39	211A3492-P1	1	1	Ident Plate
40	211A3579-P2	2	2	Rivet
41	243A4732-G1	1	1	Asm. Cable
42	243A4733-G1	1	1	Asm. Cable
43	113L104P33	1	1	Inst. Manual
44	243A4755-P1	1	1	Decal
45	243A4753-P1	1	1	Decal
46	243A4850-P1	1	1	Decal
47	155C8004 P-1	1	1	Cover-Front
48	178B8052 P-1	1	1	Cover-Rear
49	243A4915 P-1	4	4	Hinge (Wire-ty)
50	211A3579 P-3	4	4	Rivet
51	243A4916 P-1	1	1	Decal
52	243A4964P1	2	2	Connector
53	243A4965	X	X	Connection Diagram
54	26AP90BA	1		Assembly
55	243A4766G2	1		Cord Asm.
56	158C9000G1	1	1	Packaging



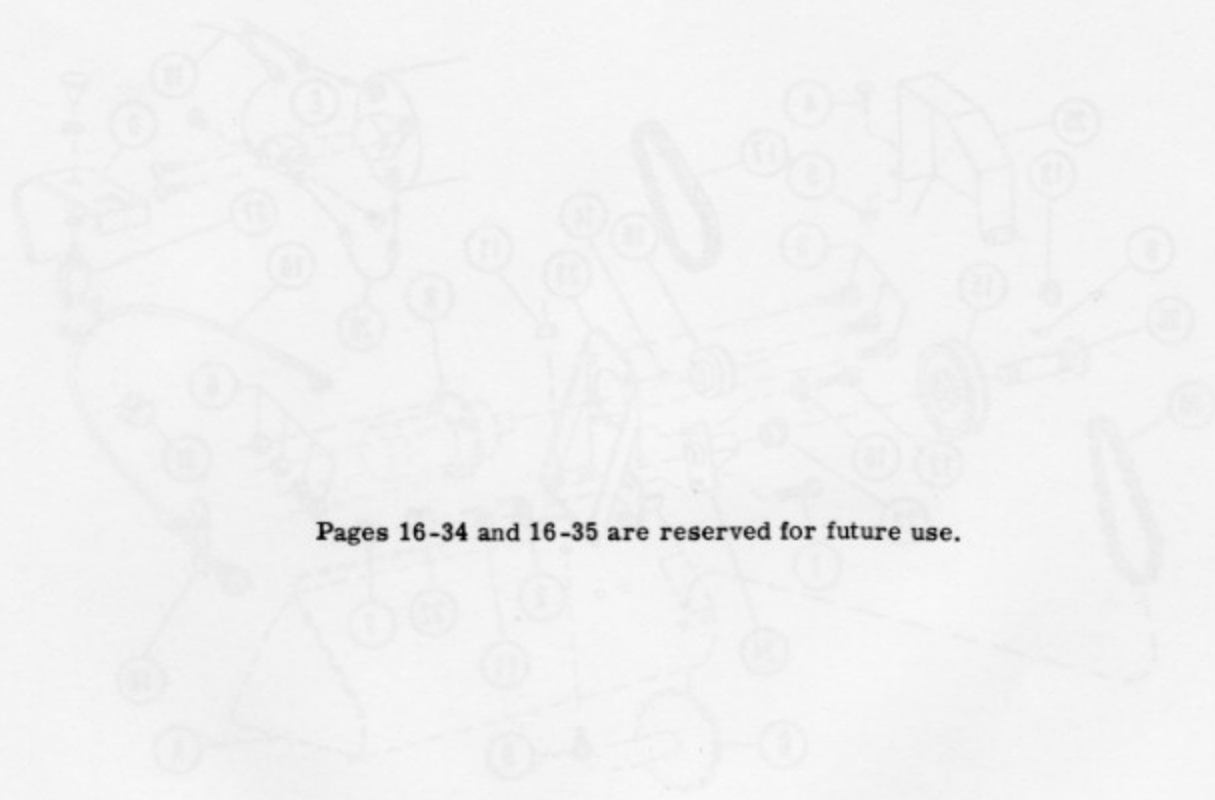

Pages 16-34 and 16-35 are reserved for future use.

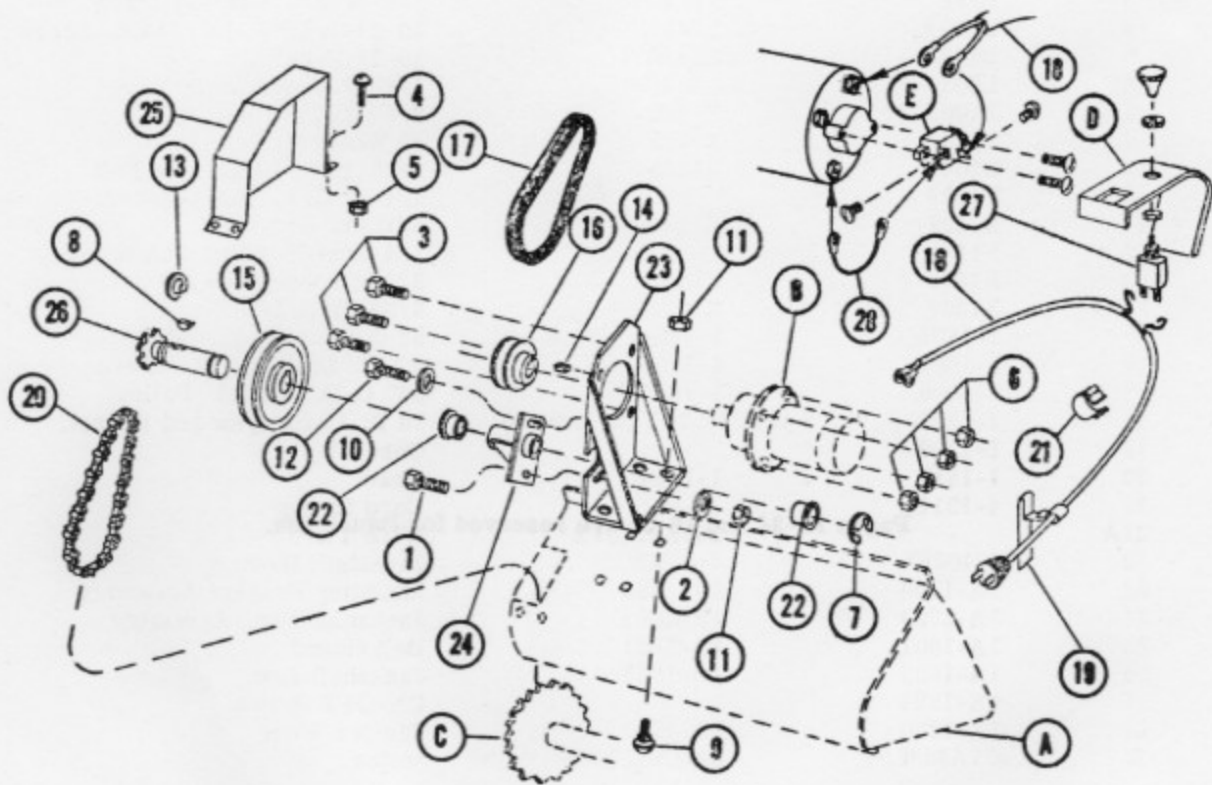

LAWNSWEEPER MOTOR KIT

Model KS 31

+

Model KS 33

When ordering parts, always specify model number, quantity and description in detail.

Send orders direct to your nearest Lambert dealer (see AS 31 for a listing). For the motor kit KS32 which is required in conjunction with the KS31 kit, contact Outdoor Power Equipment, Schenectady, New York.

<u>REF. NO.</u>	<u>PART NO. FOR KS 31</u>	<u>PART NO. FOR KS 33</u>	<u>DESCRIPTION</u>
1	L59	L59	5/16-18x3/4 Hex Cap Screw
2	L99	L99	5/16 S. A. E. Flat Washer
3	L172	L172	1/4-20x3/4 Hex Cap Screw
4	L242A	L242A	10-24x1/2 Rd. Hd. Mach. Screw
5	L242B	L242B	10-24 Kep-Nut
6	L303	L303	1/4-20 Lock Nut
7	X1003	X1003	3/4" E-Type Ret. Ring
8	X1008	X1008	#9 Woodruff Key
9	X1042	X1042	5/16-18x5/8 Carriage Bolt
10	X1099	-	1/4" S. A. E. Flat Washer
11	X1107	X1107	5/16-18 Locknut
12	X1182	-	1/4-20x1-1/4 Hex Cap Screw
13	X1363	X1363	3/4" Crescent Ring
14	X1394	X1394	5/32 Sq. x 1/2" Key
15	1-1804	1-1804	5" O. D. A-Sect. Pulley
16	1-1805	1-1805	2 1/2" O. D. A-Sect. Pulley
17	1-1806	1-1806	20" O. D. A-Sect. Pulley
18	1-1808	191B4553G1 (no switch)	10 ft. Cord w/sw and Recept.
19	1-1809	-	Cord Clip
20	1-1810	1-1810	Chain
21	4-10146	-	Cord Clamp
21A	-	243A4540 P2	Wire Tie
22	4-10697	4-10697	Jackshaft Bushing
23	1A-1794	1A-1893	Mounting Bracket Assembly
24	1A-1798	1A-1892	Jackshaft Mtg. Assembly
25	1A-1801	1A-1801	Belt Guard
26	1A-1803	1A-1803	Jackshaft Asm.
27	1A-1824	-	ON-OFF Switch
28	1A-1830	1A-1831	Jumper Wire
B	211A3435 P1	541C9017 P1	Motor

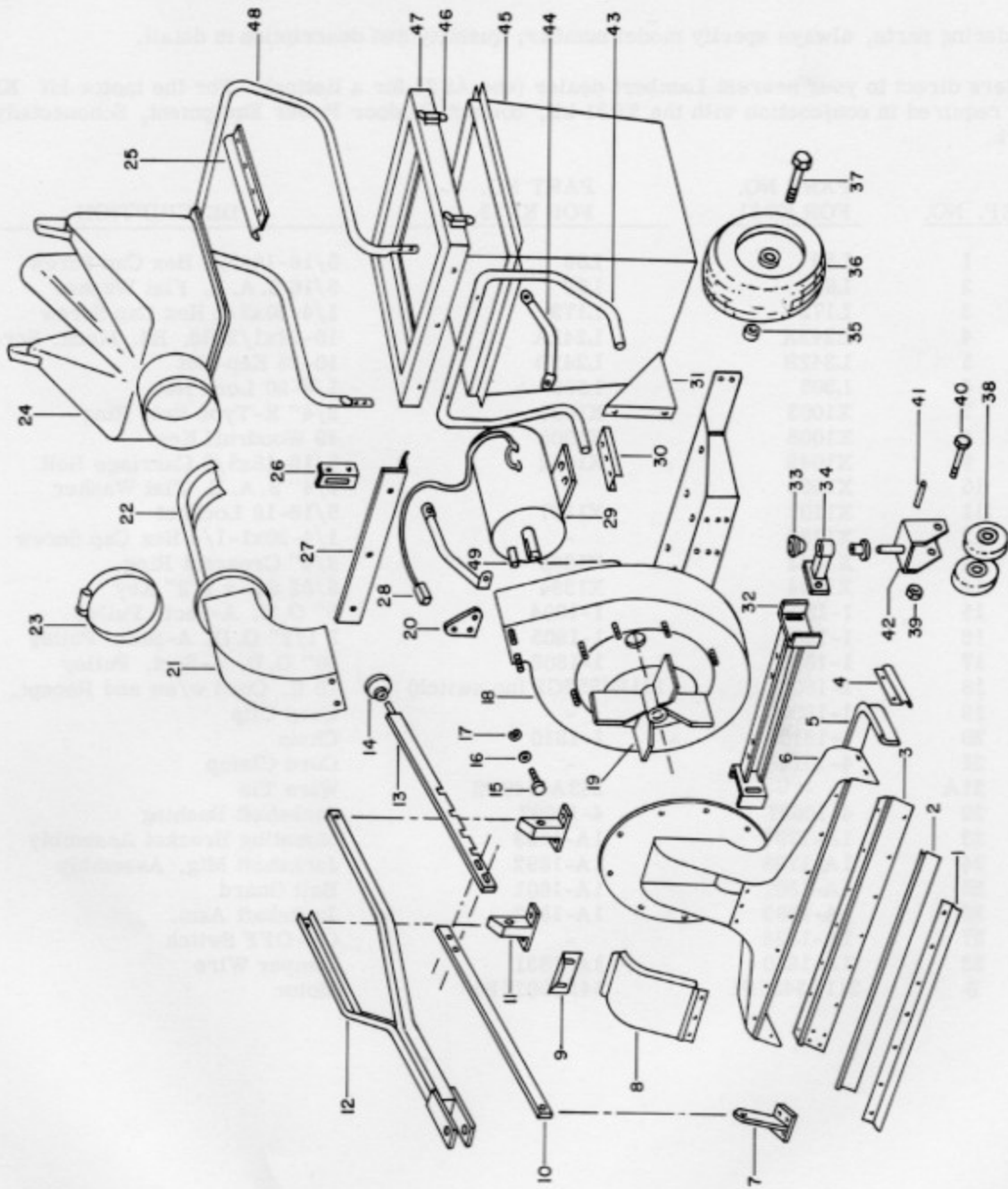

VACUUM  
Model CV 60

When ordering parts, always specify model number, quantity, and description in detail.

Send orders direct to: Sensation Products  
Russell Road  
East Granby, Connecticut 06026

or call: Area Code (203) 658-2226

<u>Ref. No.</u>	<u>Part No.</u>	<u>Description</u>
1	60352-0	Clamping Strip Front and Rear
2	60351	Skirt, Door
3	40111-0	Door Assembly
4	60353-0	Clamping Strip Side
5	60350	Skirt - Rear and Side
6	40103-0	Intake Housing
7	40222-0	Bracket Assembly
8	40109-0	Cover Assembly
9	60018-0	Lever, Lower
10	60218-0	Latch
11	40375-0	Tow Bracket
12	40379-0	Tow Bar
13	60219-0	Lever Upper
14	60244	Knob
15	60077	Bolt 5/16-24 x 1 3/4
16	60076	Washer 5/16 Lock
17	60075	Washer 5/16 Flat
18	40388	Housing Assembly
19	40079	Impeller 12" Dia.
20	60486-0	Plate, Brace
21	40138-0	Chute Assembly
22	60144-0	Deflector
23	60149	Clamp 8"
24	60233	Venting Bag
25	60285	Clamping Strip
26	60221	Bracket, Lever Locking
27	60281	Guide Angle
28	40404	Wiring Harness
29	60391	Motor G. E.
30	60095-0	Riser Channel
31	60392-0	Brace Housing to Base
32	40118-0	Carrier Bar Assembly
33	60131	Bearing
34	40126	Caster Extension
35	60025	Nut, Lock 5/8-18
36	60359	Wheel Pneumatic 10"
37	60029	Bolt 5/8-18 x 3 3/4
38	60026	Wheel 5" Dia.
39	60025	Nut, Lock 3/8-16
40	60024	Bolt 3/8-16 x 4
41	60023	Sleeve Axle
42	40125-0	Caster Bracket
43	60229	Handle Lower
44	60139	Brace
45	40288	Container
46	60290	Catch
47	40279-0	Frame Assembly Container
48	60230	Handle Upper

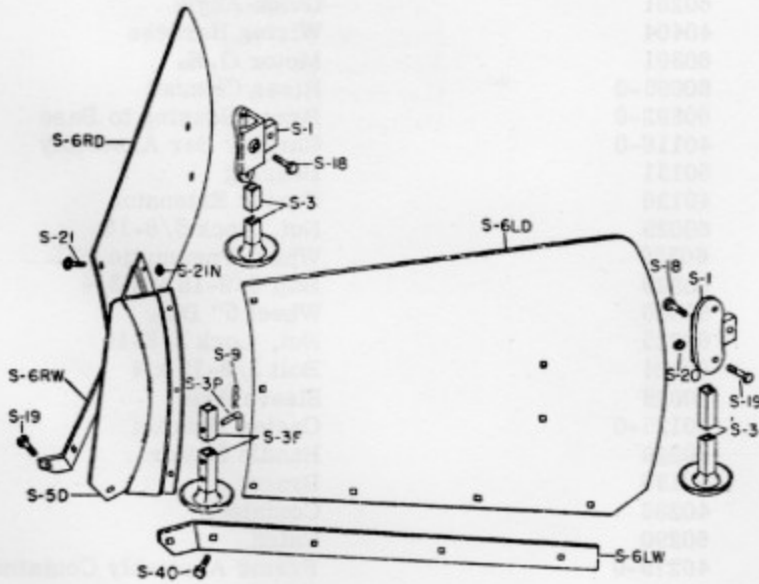
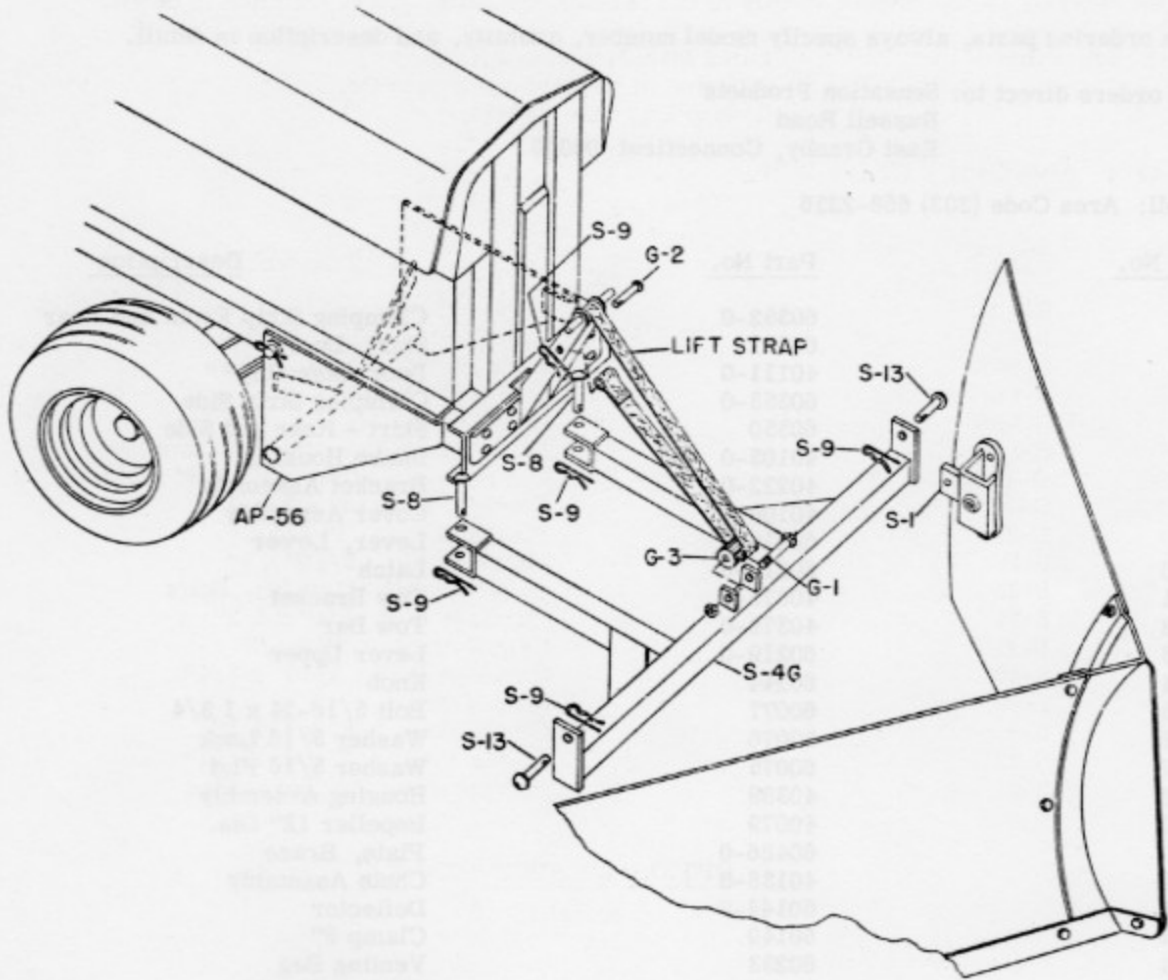

V-PLOW  
Model BV 48

When ordering parts, always specify model number, quantity, and description in detail.

Send orders direct to:                   Lantz Manufacturing Division  
Superior Implement and Supply Co.  
Greenville, Ohio 45331

or call: Area Code (513) 548-2171

<u>Part No.</u>	<u>Description</u>
S-5D	Center Nosepiece
S-6LD	Left Blade Section, Deluxe
S-6RD	Right Blade Section, Deluxe
S-6LW	Left Wear Edge
S-6RW	Right Wear Edge
S-1	Main Frame Mounting Brackets
G-1	Cap Screw and Grip Nut, 3/8" x 2-3/4"
G-2	Clevis Pin, 5/16" x 2-1/2"
G-3	Plastic Sleeve, 2" Long
S-19	Carriage Bolt, 5/16" x 1"
S-20	Grip Nuts for 5/16" Dia. Bolts
S-21	Carriage Bolt, 1/4" x 1/2"
S-21N	Grip Nuts for 1/4" x 1/2"
S-40	Carriage Bolts, 5/16" x 3/4"
S-4G	Main Frame
S-8	Clevis Pins, 3/8" x 1-7/8"
S-13	Clevis Pins, 1/2" x 1-27/64"
S-9	Hairpin Clips for Clevis Pins

OPTIONAL GAUGE SHOE KIT

Model KS 30

<u>Part No.</u>	<u>Description</u>
S-3	Gauge Shoe, Side
S-3F	Gauge Shoe, Front
S-3P	Front Gauge Shoe Pin
S-18	Cap Screw, 3/8" x 3/4"
S-9	Hairpin Clip

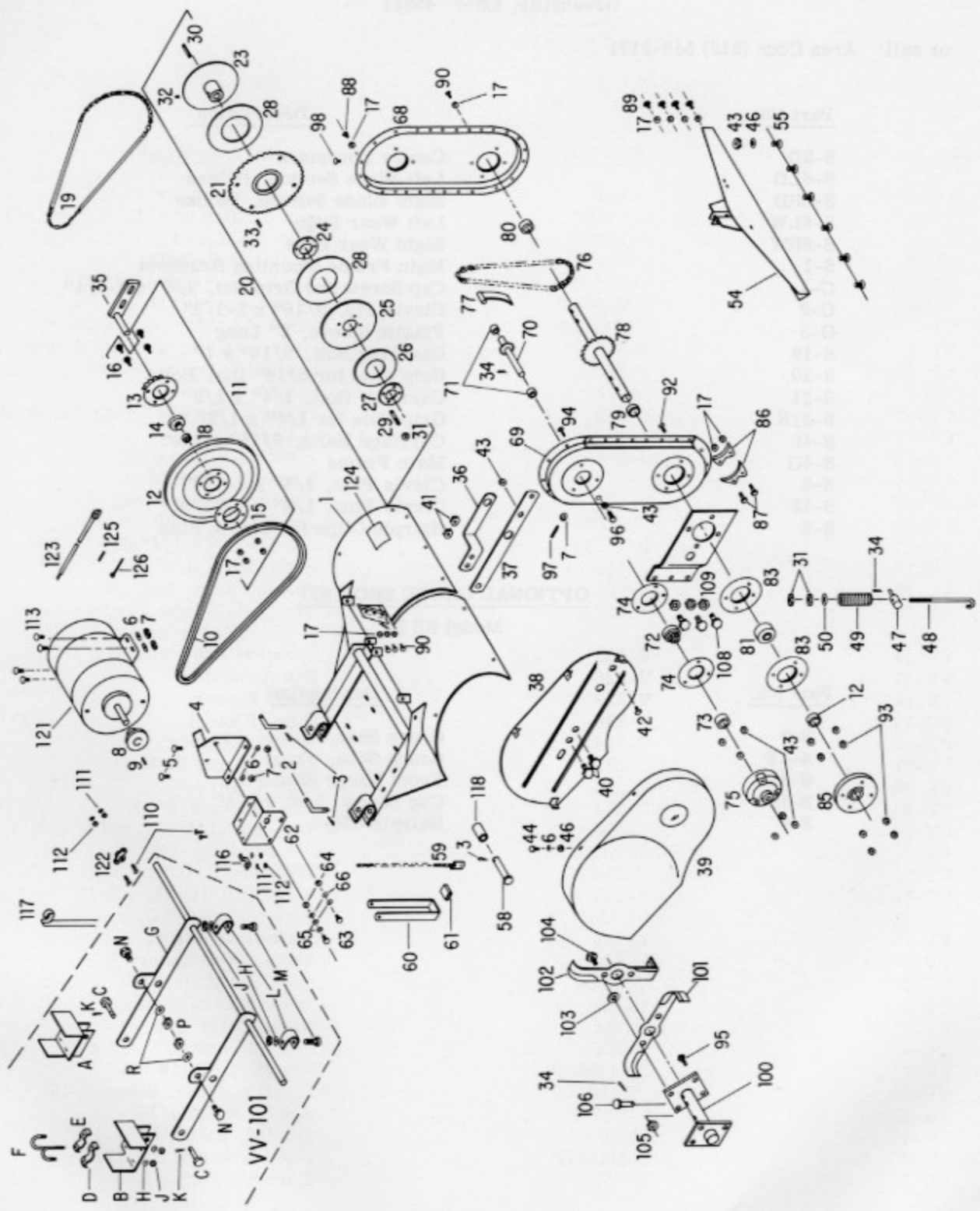

## ROTARY TILLER

Model VV 100

When ordering parts, always include part number and full description.

Send orders direct to: Brinly-Hardy Company, Inc.  
340 E. Main Street  
Louisville, Kentucky 40202

or call: Area Code (502) 585-3351

Ref. No.	Part No.	Description
VV-1	V-114	Shroud Assembly
VV-2	B-1610P	Pin, Drilled 5/8" D.
VV-3	D-146P	Hair Pin Cotter 1/8" x 1 7/8"
VV-4	V-126	Shield, Belt-Motor
VV-5	1M1012P	Hex Hd. Bolt, 5/16-18 x 3/4"
VV-6	40M1000P	Lockwasher 5/16"
VV-7	30M1000P	Hex Nut 5/16"
VV-8	V-127	Pulley, Driver with Set Screw
VV-9	V-158	Key 3/16" Sq. x 1 1/4"
VV-10	V-131	V Belt
VV-11	V-132	Pulley & Sprocket Assy (Mech. Asm.)
VV-12	V-133	Pulley - 11"
VV-13	V-134	Sprocket & Cup Assy
VV-14	V-137	Bearing 3/4" Sealed
VV-15	V-138	Washer, Reinforcing
VV-16	2M0810P	Hex Bolt 1/4"-20 x 5/8"
VV-17	B-1673P	Hex Lock Nut 1/4"-20
VV-18	V-139	Lock Collar 3/4"
VV-19	V-145	Roller Chain, ASA-50
VV-20	V-322	Sprocket-Torque Limiter Assy (Mech. Ass'm.)
VV-21	V-323	Sprocket Assembly with Bushing
VV-23	V-326	Hub Assembly
VV-24	V-329	Ring, Spacer
VV-25	V-330	Disc. (Outer)
VV-26	V-331	Spring, Washer
VV-27	V-332	Ring, Spring Deflector
VV-28	V-333	Clutch, Disc
VV-29	V-334	Stud, Spec. 3/8" D.
VV-30	V-335	Key, Sq. (1/4" Sq. x 1 3/4")
VV-31	30M1200P	Hex Nut 3/8"-16
VV-32	V-336	Set Screw 5/16" x 1/4"
VV-33	V-355	Roll Pin 5/16" D. x 3/4"
VV-34	50M0416P	Cotter Pin 1/8" D. x 1.0"
VV-35	V-146	Shaft-Arm Ass'y.
VV-36	V-149	Arm, Pivot (Outer)
VV-37	V-150	Arm, Pivot (Inner)
VV-38	V-151	Shield Ass'm., Inner
VV-39	V-154	Shield Outer (Outer)
VV-40	V-295	Hex Hd. Bolt 5/8"-18 x 2"
VV-41	32M2000P	Hex Nut 5/8"-18
VV-42	25M1016P	Flat Hd. Mach. Screw 5/16" x 1.00"
VV-43	B-1674P	Hex Lock Nut 5/16"-18
VV-44	1M1008P	Hex Hd. Bolt 5/16" x 1/2"
VV-46	45M1111P	Flat Washer 5/16" SAE
VV-47	V-155P	Trunnion-Spring Rod

ROTARY TILLER (Continued)

Model VV 100

<u>Ref. No.</u>	<u>Part No.</u>	<u>Description</u>
VV-48	V-156P	"J" Bolt
VV-49	V-157P	Compression Spring
VV-50	45M1313P	Flat Washer 3/8" SAE
VV-52	45M1717P	Flat Washer 1/2" SAE
VV-54	V-159	Shroud Brace Ass'm. W. A.
VV-55	11M1012P	Carr. Bolt 5/16"-18 x 3/4"
VV-58	V-163P	Pin, Drilled 1/2" D. x 4 1/4"
VV-59	V-359P	Limit Chain Ass'm.
VV-60	V-369	Lift Limiter
VV-61	V-370	Pad-Vinyl
VV-62	V-361	Bracket-Circuit Breaker
VV-63	1M0812P	Hex Bolt 1/4"-2 x 3/4"
VV-64	30M0800P	Hex Nut 1/4"-20
VV-65	45M0909P	Flat Washer 1/4" SAE
VV-66	40M0800P	Lock Washer 1/4"
VV-68	V-167	Chain Housing Ass'm. (R.H.)
VV-69	V-172	Chain Housing Ass'm. (L.H.)
VV-70	V-174	Shaft & Sprocket Ass'm. 10T
VV-71	V-177	Spacer, Drive Shaft
VV-72	V-178	Bearing 1" Sealed
VV-73	V-179	Lock-Collar (1")
VV-74	V-180	Flangette Half - 1"
VV-75	V-181	Hub, Pivot (for 1" Shaft)
VV-76	V-182	Chain, Roller (ASA 60)
VV-77	V-183	Chain Tightener Ass'm.
VV-78	V-186	Tine Shaft & Sprocket Ass'm.
VV-79	V-190	Spacer, Tine Shaft (Long)
VV-80	V-191	Spacer, Tine Shaft (Short)
VV-81	V-192	Bearing 1 1/4" Bore
VV-82	V-193	Locking Collar 1 1/4"
VV-83	V-194	Flangette Half 1 1/4"
VV-84	V-195	Plate-Attaching (Lower)
VV-85	V-196	Cap, Bearing Guard
VV-86	V-197	Wear Bar
VV-87	2M0832P	Hex Bolt 1/4"-20 x 2.00"
VV-88	13M0808P	Carriage Bolt (Short Sq. Neck)
VV-89	11M0816P	Carriage Bolt 1/4" x 1"
VV-90	10M0812P	Carriage Bolt 1/4" x 3/4"
VV-92	V-207	Carriage Bolt Gr. 5 3/8"-16 x 1 1/2" Thd. to Hd.
VV-93	B-1675P	Hex Lock Nut 3/8"-16
VV-94	V-199P	Carriage Bolt 5/16"-18 x 1 1/2"
VV-95	2M1416P	Hex Bolt 7/16 x 1"
VV-96	1M1032P	Hex Bolt 5/16-18 x 2"
VV-97	V-200	Hex Socket Set Screw 5/16"-18 x 1 1/2"
VV-98	V-201	Cover, Oil Hole
VV-100	V-376	Tine Attachment Ass'm.
VV-101	M43480	Tine R.H. 1/4" x 13-1/2"
VV-102	M43481	Tine L.H. 1/4" x 13 1/2"
VV-103	B723	Washer-Spec.
VV-104	2M1424P	Hex Bolt 7/16"-14 x 1 1/2"
VV-105	B-1676	Hex Lock Nut 7/16"-14
VV-106	B-1345P	Pin-Tine Tub. Conn. 1/2" D. x 2"
VV-108	2M1632P	Hex Bolt 1/2"-13 x 2"
VV-109	B-1677P	Hex Lock Nut 1/2"-13

ROTARY TILLER (Continued)

Model VV 100

<u>Ref. No.</u>	<u>Part No.</u>	<u>Description</u>
VV-110	V-128P	Pan Head Mach. Screw-Phillips Hd. 10-32 x 7/8"
VV-111	V-130P	Lockwasher #10
VV-112	V-129P	Hex Nut #10-32
VV-113	1M1012P	Carriage Bolt 5/16"-18 x 3/4"
VV-116	V-362P	Cable Clamp
VV-117	V-375	Clip-Power Cable
VV-118	V-374	Tube-Roller
VV-121*	163B9956P1	Motor-Tiller
VV-122*	243A4606P1	Circuit Breaker
VV-123*	243A4528G1	Cord Ass'm.
VV-124*		Decal, Caution
VV-125*	211A3556G3	Jumper Wire
VV-126*	243A4540P2	Cable Tie

TILLER MOUNTING BRACKET

Model VV 101A

<u>Ref. No.</u>	<u>Part No.</u>	<u>Description</u>
VV-A	V-100	Axle Bracket, R. H.
VV-B	V-101	Axle Bracket, L. H.
VV-C	H200P	Drilled Rivet 1/2" D. x 1 1/2"
VV-D	V-106	Spacer, Axle (Outer-Heavy)
VV-E	V-107	Spacer, Axle (Inner-Light)
VV-F	V-108P	"U" Bolt 3/8" D.
VV-G	V-109A	Bail Ass'm.
VV-H	40M1200P	Lock Washer 3/8"
VV-J	30M1200P	Hex Nut 3/8"-16
VV-K	D-146P	Hair Pin Cotter 1/8" x 1 7/8"
VV-L	V-105	Clevis-Positioning
VV-M	10M1232P	Carriage Bolt 3/8"-16 x 2"
VV-N	1M1620P	Hex Bolt 1/2"-13 x 1 1/4"
VV-P	30M1600P	Hex Nut 1/2"-13
VV-R	40M1600P	Lock Washer 1/2"

\*GE Parts - Available through O. P. E. O.  
All other parts available through Brinly-Hardy Co.

ROBANT TRAKER

Model VV 100



- Part No.
- VV-110
- VV-111
- VV-112
- VV-113
- VV-114
- VV-115
- VV-116
- VV-117
- VV-118
- VV-119
- VV-120
- VV-121
- VV-122
- VV-123
- VV-124
- VV-125
- VV-126

- Part No.
- VV-A
- VV-B
- VV-C
- VV-D
- VV-E
- VV-F
- VV-G
- VV-H
- VV-I
- VV-J
- VV-K
- VV-L
- VV-M
- VV-N
- VV-O
- VV-P

12 CUBIC FOOT DUMP CART

MODEL AF 12

WHEN ORDERING PARTS, ALWAYS INCLUDE PART NUMBERS AND  
FULL DESCRIPTION.

SEND ORDERS DIRECT TO: OHIO STEEL FABRICATORS  
2575 FERRIS ROAD  
COLUMBUS, OHIO 43224

OR CALL: AREA CODE (614) 471-4800

<u>REF. NO.</u>	<u>PART NO.</u>	<u>DESCRIPTION</u>
AF-1	3648-1	BODY
AF-2	3648-7	LATCH SPACER
AF-3	3648-8	STRUT (2 REQUIRED)
AF-4	3648-9	DRAW BAR
AF-5	3648-10	WHEEL (2 REQUIRED)
AF-6	3648-11	AXLE

ENCLOSED CAB

Model AG 55

When ordering parts, always specify cab, model number, part number and description in detail.

Send orders direct to: Curtis Tractor Cab, Inc.  
7 Brookfield Street  
Worcester, Massachusetts 01605

or call: Area Code (617) 752-4086

Each cab is guaranteed one year to be free of defects in parts and workmanship. Under guarantee all defective parts must be returned to Curtis, freight prepaid, and replacements will be returned freight collect.

<u>Part No.</u>	<u>Description</u>
AG-1	Roof
AG-2	Front, Complete with Glass Windshield
AG-3	Front, Without Glass Windshield
AG-4	Rear Legs, Right and Left
AG-5	Left Side Curtain with Zipper
AG-6	Right Side Curtain
AG-7	Rear Curtain
AG-8	Windshield Wiper Motor (12-volt)
AG-9	Windshield Wiper Arm
AG-10	Windshield Wiper Blade
AG-11	Male Snaps for Cab (Require Rivets)
AG-12	Rivets (Special Machine Required to Set - <u>Not Available</u> )
AG-13	Threaded Male Snaps and Nuts
AG-14	Rubber for Mounting Windshield Glass
AG-15	Safety Glass for Windshield
AG-16	5/16-18 Bolt, Nut and Washer
AG-17	5/8 I. D. Grommet for Wiper Installation
AG-18	3/16 I. D. Grommet for Wiper Installation
AG-19	Cab Shipping Carton
AG-20	Mounting Pads for Fenders (2 Required)
AG-21	Mounting Pad for Windshield

CANOPY TOP, DOUBLE SEAT, GOLF BAG HOLDER

Model BC 11    Model BD 22    Model BG 33

When ordering parts, always specify model number, quantity, and description in detail.

Send orders direct to:

Breton Industries, Inc.  
10 Leonard Street  
Amsterdam, New York

or call: Area Code (518) 374-5329

CANOPY TOP

Model BC 11

<u>Qty.</u>	<u>Description</u>
1	Canopy Cover
2	Front and Rear Frame Member
2	Side Frame Member
2	Front Upright
2	Rear Upright
1	Front Mounting Bracket
2	Rear Mounting Bracket
2	Rear Cross Brace
8	1/2-20 x 3/4" Hex Bolt
2	1/4-20 x 1 1/4" Hex Bolt
2	1/4-20 x 1/2" Hex Bolt
12	1/4-20 Lock Nut
2	5/16-18 x 3/4" Hex Bolt
2	5/16-18 x 1" Hex Bolt
4	Washer
4	5/16-18 Lock Nut

DOUBLE SEAT

Model BD 22

<u>Qty.</u>	<u>Description</u>
2	Arms
1	Seat Back
1	Seat Bottom
8	5/16-18 x 1 1/2" Black Cap Screws
4	5/16-18 x 1 1/2" Plated Cap Screws
4	Leveler Bolts
8	Washers

GOLF BAG HOLDER

Model BG 33

<u>Qty.</u>	<u>Description</u>
1	Bag Rest
1	Tubular Upright
1	Base Box
1	Left Stabber
1	Right Stabber
1	44" Nylon Bearing
3	1/4-20 x 1 1/2" Hex Head Cap Screw
1	1/4-20 x 1 3/4" Hex Head Cap Screw
4	1/4-20 Lock Nut
4	5/16-18 x 3/4" Hex Head Cap Screw
4	5/16-18 Lock Nut

# MODEL TM3 POWER UNIT

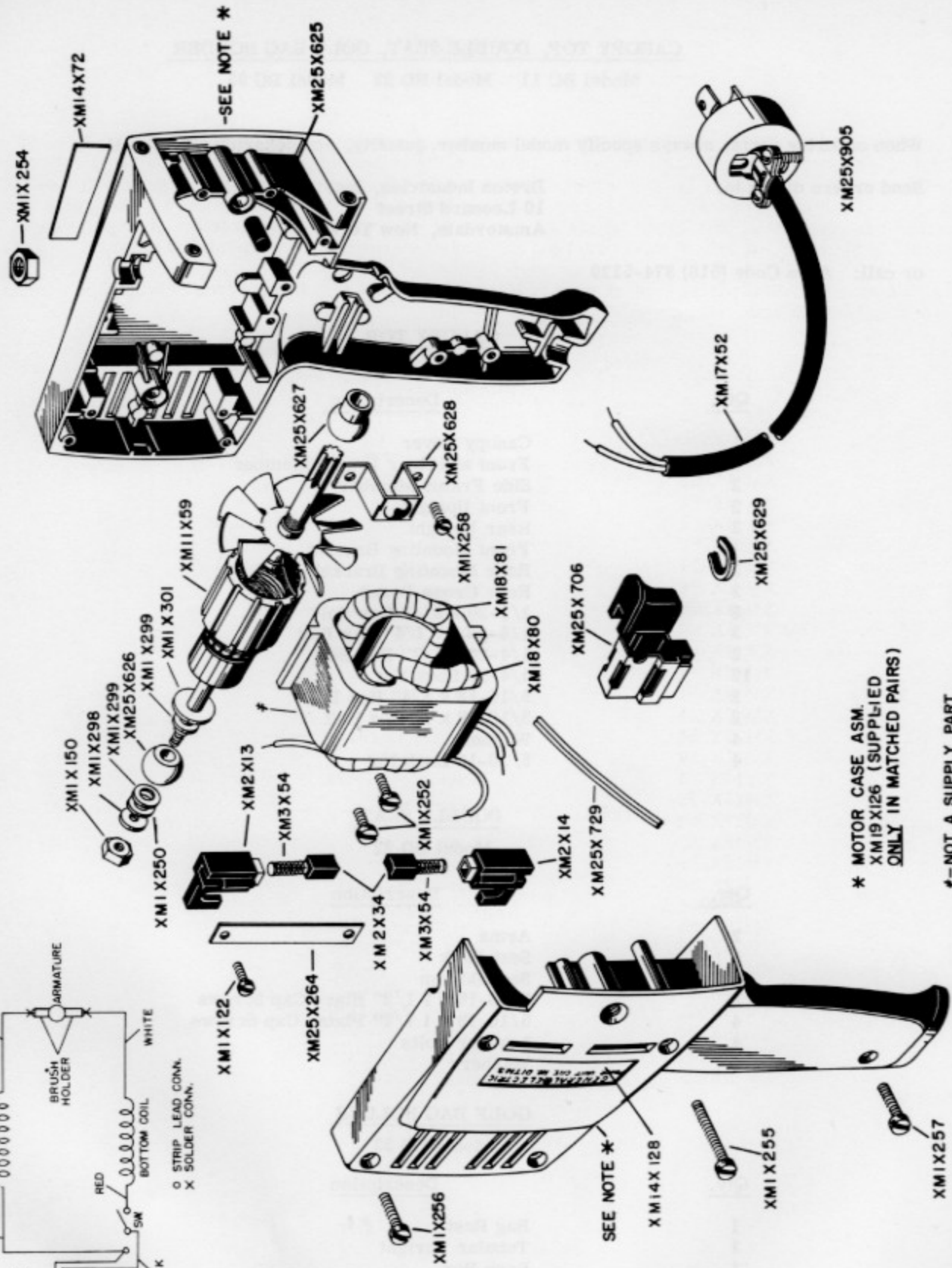
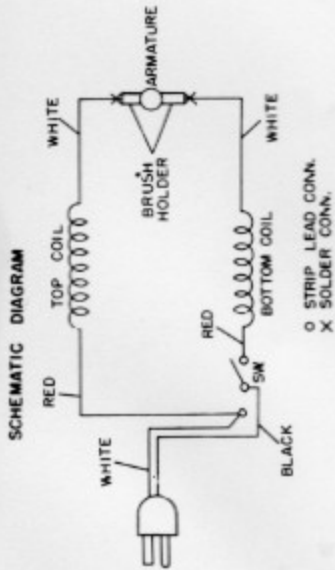

## POWER UNIT

### Model TM 3

The Model TM 3 POWER UNIT is designed to be used in conjunction with the models TH 20 (1/4" or TH 30 (3/8") drills, TH 70 hedge trimmer and/or the TH 80 grass trimmer to make a complete power tool assembly. It develops 1/3 horsepower, has a die cast aluminum housing, a trigger switch (which can be locked for continuous running) and a 20 foot yellow line cord with an armored locking plug at its end. Arrangement has been made for the attachment of helper handles in three areas or positions. The D1TM3 is approved for use on direct current only and at 36 volts D.C. is rated 7.0 amps.

For spare and renewal parts, contact your nearest General Electric Housewares Service Center; see attachment for address, telephone, etc.

<u>Part No.</u>	<u>Description</u>
XM 1X122	Screw Bearing Cap
XM 1X150	Nut Armature
XM 1X250	Washer, Armature
XM 1X252	Screw, Field
XM 1X254	Nut, Helper Handle
XM 1X255	Screw, Motor Mount (Front)
XM 1X256	Screw, Motor Case (Rear)
XM 1X257	Screw, Motor Case (Handle)
XM 1X258	Screw, Bearing Strap
XM 1X298	Washer, Armature
XM 1X299	Washer, Armature
XM 1X301	Washer, Armature
XM 2X 13	Brush Holder, R.H.
XM 2X 14	Brush Holder, L.H.
XM 2X 34	Brush
XM 3X 54	Spring, Carbon Brush
XM11X 59	Armature
XM14X 72	Escutcheon Plate
XM14X128	Rating Plate
XM17X 52	Power Cord
XM18X 80	Coil, Upper
XM18X 81	Coil, Lower
XM19X126	Case Assembly
XM25X264	Bearing Cap
XM25X625	Oil Wick
XM25X626	Bearing, Rear
XM25X627	Bearing, Front
XM25X628	Bearing Strap
XM25X629	Strain Relief Clip
XM25X706	Switch
XM25X729	Wire, Field Retaining
XM25X905	Plug, Power Cord

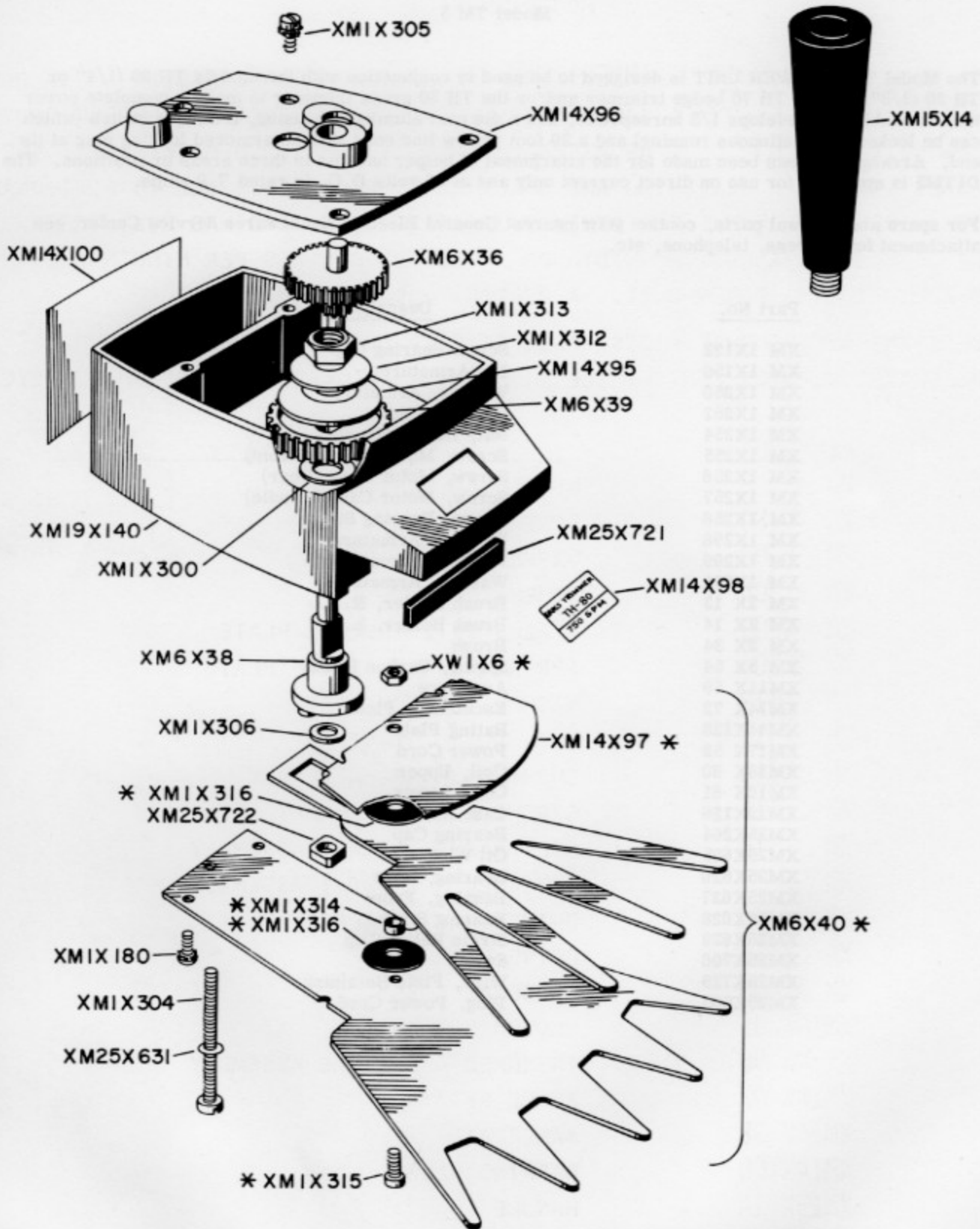

\* - INCLUDES ALL PARTS IN A COMPLETE ASM.

# GRASS TRIMMER HEAD

## MODEL TH 80

THE MODEL TH 80 GRASS TRIMMER HEAD IS DESIGNED TO OPERATE WITH ANY ONE OF THE GENERAL ELECTRIC POWER UNITS. IT HAS A DIE CAST ALUMINUM HOUSING, A TWO-STAGE REDUCTION GEAR ASSEMBLY AND A SLIP-CLUTCH MECHANISM. THE BLADES ARE SELF-SHARPENING AND BLACK-OXIDE FINISHED. ONE IS STATIONARY WITH FIVE TEETH WHILE THE OTHER IS RECIPROCATING AND HAS FOUR TEETH. THE 17TH80 HAS A CUTTING WIDTH OF 5" AT 750 STROKES PER MINUTE WHEN ATTACHED TO THE POWER UNIT. A HELPER HANDLE IS INCLUDED.

FOR SPARE AND RENEWAL PARTS, CONTACT YOUR NEAREST GENERAL ELECTRIC HOUSEWARES SERVICE CENTER; SEE ATTACHMENT FOR ADDRESS, TELEPHONE, ETC.

<u>PART NO.</u>	<u>DESCRIPTION</u>
XW 1X 6	NUT, BLADE ASSEMBLY
XM 1X180	SCREW, BLADE TO CASE
XM 1X300	WASHER, DRIVE SHAFT
XM 1X304	SCREW, CAPTIVE
XM 1X305	SCREW, INTERMEDIATE PLATE
XM 1X306	SPRING WASHER, DRIVE PLATE
XM 1X312	WASHER, CLUTCH PLATE
XM 1X313	NUT, DRIVE SHAFT
XM 1X314	BUSHING, BLADE ASSEMBLY
XM 1X315	SCREW, BLADE ASSEMBLY
XM 1X316	FELT WASHER, BLADE ASSEMBLY
XM 6X 36	INTERMEDIATE SHAFT ASSEMBLY
XM 6X 38	DRIVE SHAFT ASSEMBLY
XM 6X 39	DRIVE GEAR
XM 6X 40	BLADE ASSEMBLY
XM14X 95	CLUTCH PLATE
XM14X 96	INTERMEDIATE PLATE ASSEMBLY
XM14X 97	BLADE RETAINER
XM14X 98	NAMEPLATE
XM14X100	WARNING LABEL
XM15X 14	HANDLE
XM19X140	CASE ASSEMBLY
XM25X631	RETAINING RING
XM25X721	FELT DIRT SEAL
XM25X722	FOLLOWER

GRASS TRIMMER HEAD

MODEL TB 80

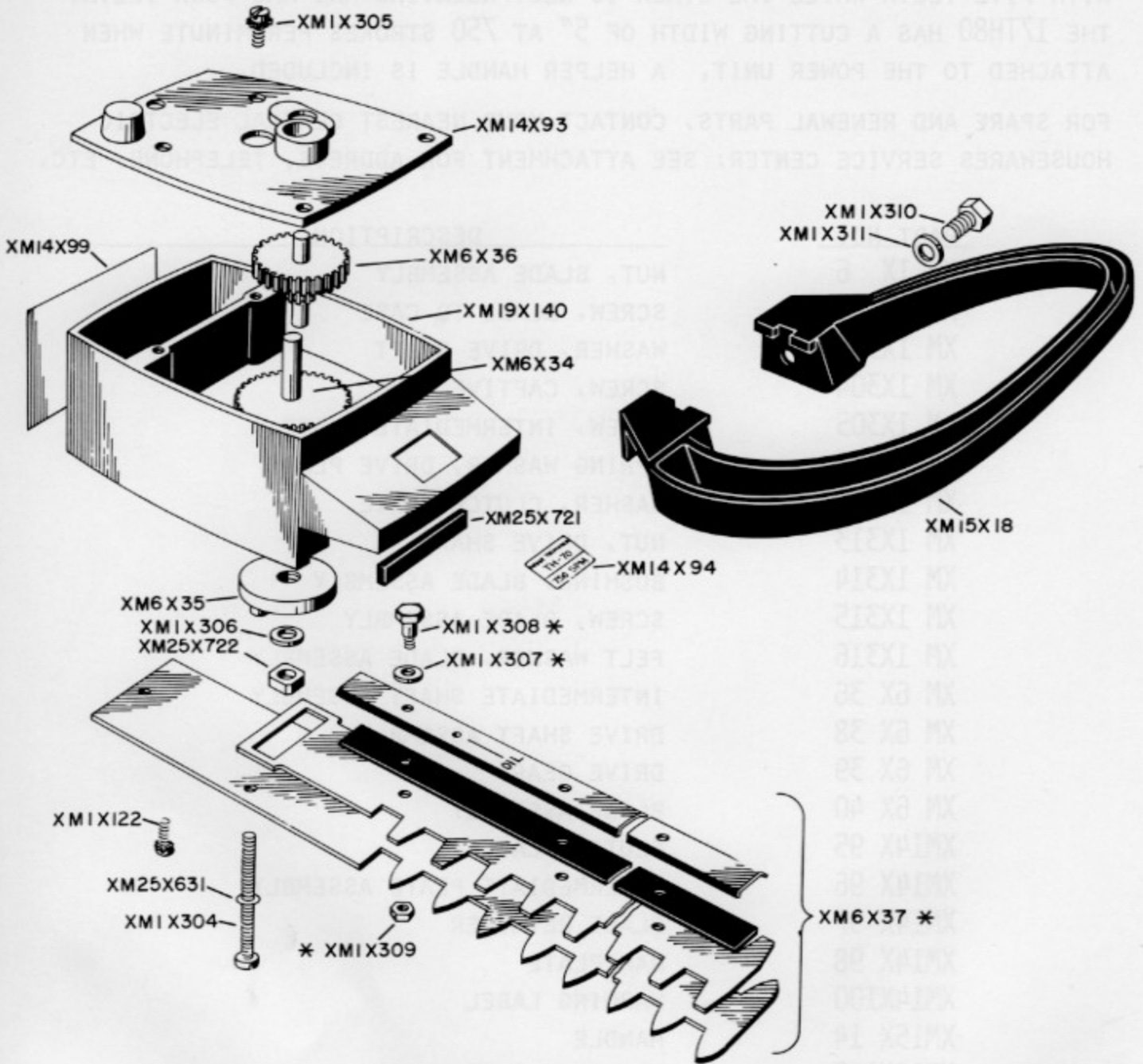

\* - INCLUDES ALL PARTS  
IN A COMPLETE ASM.

## HEDGE TRIMMER HEAD

### MODEL TH 70

THE MODEL TH 70 HEDGE TRIMMER HEAD IS DESIGNED FOR USE WITH ANY ONE OF THE GENERAL ELECTRIC POWER UNITS. IT HAS A DIE-CAST ALUMINUM HOUSING, A TWO-STAGE REDUCTION GEAR ASSEMBLY, WHICH CAUSES THE BLADES TO OPERATE AT 750 STROKES PER MINUTE. THE BLADES ARE 15" LONG, ARE BLACK-OXIDE FINISHED AND SELF-SHARPENING. A BALE TYPE PLASTIC HANDLE IS INCLUDED.

FOR SPARE AND RENEWAL PARTS, CONTACT YOUR NEAREST GENERAL ELECTRIC HOUSEWARES SERVICE CENTER; SEE ATTACHMENT FOR ADDRESS, TELEPHONE, ETC.

<u>PART NO.</u>	<u>DESCRIPTION</u>
XM 1X122	SCREW, BLADE ASSEMBLY
XM 1X304	SCREW, CAPTIVE
XM 1X305	SCREW, INTERMEDIATE PLATE
XM 1X306	SPRING WASHER, DRIVE PLATE
XM 1X307	SPRING WASHER, BLADE ASSEMBLY
XM 1X308	SCREW, BLADE ASSEMBLY
XM 1X309	LOCKNUT, BLADE ASSEMBLY
XM 1X310	BOLT, HANDLE
XM 1X311	WASHER, HANDLE
XM 6X 34	DRIVE SHAFT ASSEMBLY
XM 6X 35	DRIVE PLATE
XM 6X 36	INTERMEDIATE SHAFT ASSEMBLY
XM 6X 37	BLADE ASSEMBLY
XM14X 93	INTERMEDIATE PLATE ASSEMBLY
XM14X 94	NAMEPLATE
XM14X 99	WARNING PLATE
XM15X 18	HANDLE
XM19X140	CASE ASSEMBLY
XM25X631	RETAINING RING
XM25X721	FELT DIRT SEAL
XM25X722	FOLLOWER

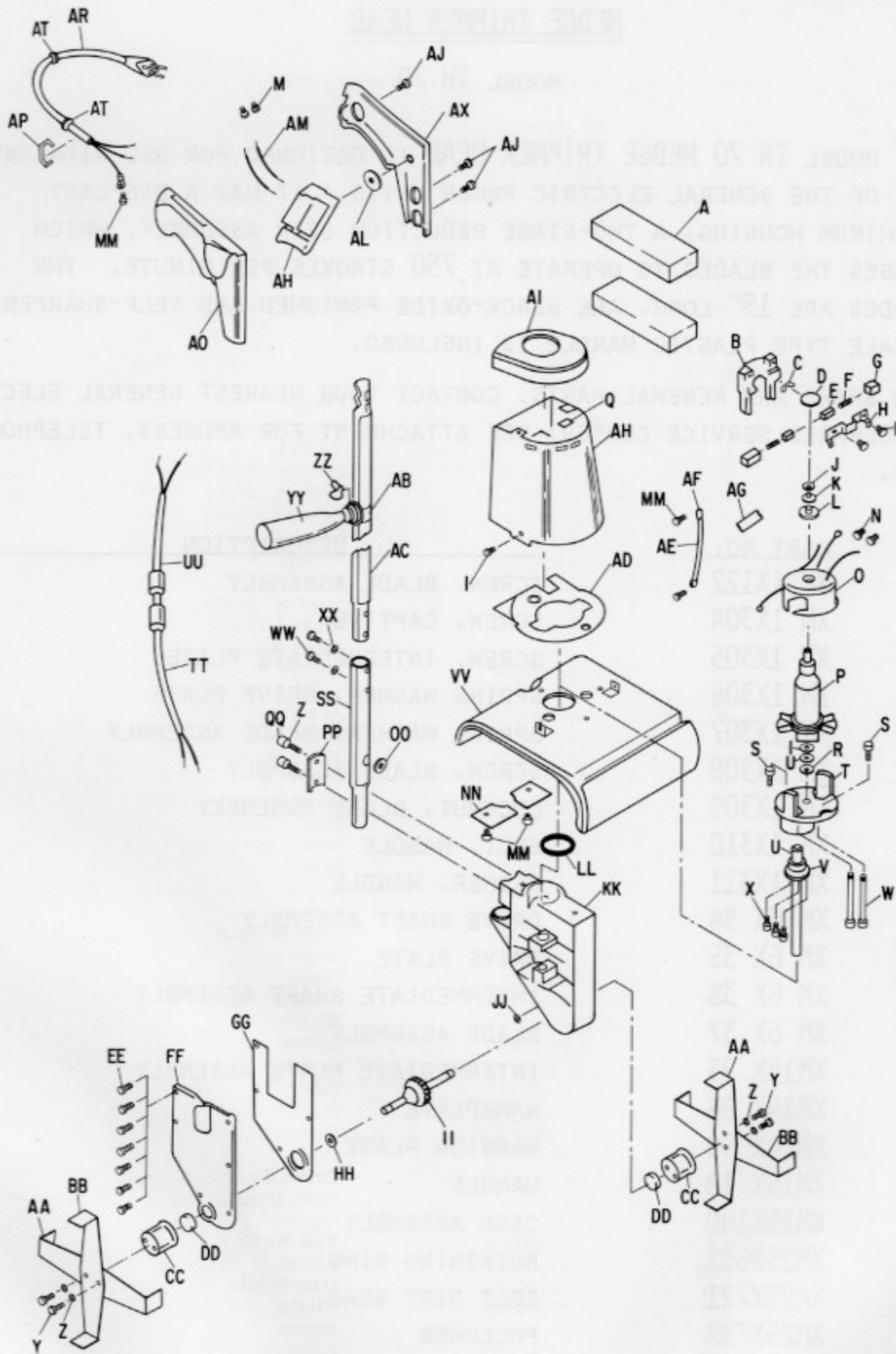

WEEDER CULTIVATOR

Model HC 05

When ordering parts, always include part number, model number, and full description.

Send orders direct to:

Mc Graw Edison  
 Power Tool Division  
 Parts and Service Dept.  
 1501 East Main Street  
 St. Charles, Illinois 60174

or call: Area Code (312) 584-1750

Minimum order is \$2.00 with terms of net 30 F.O.B. St. Charles, Illinois.

<u>Ref. No.</u>	<u>Ref. Letter</u>	<u>Part No.</u>	<u>Description</u>
HC-1	A	01-01525	Filter
HC-2	B	06-00474	Stator Bracket
HC-3	C	01-00452	Oil Felt
HC-4	D	09-00044	Bronze Bearing
HC-5	E	14-00094	Carbon Brush
HC-6	F	14-00068	Brush Spring
HC-7	G	14-00045	Brush Holder
HC-8	H	27-00054	Spring, Brush Holder & Bearing
HC-9	I	22-00713	Screw
HC-10	J	27-00008	Loading Spring
HC-11	K	17-00313	Fibre Washer
HC-12	L	17-00100	Fibre Washer
HC-13	N	16-00004	Connector
HC-14	O	08-00222	Field Assembly
HC-15	P	07-00217	Armature Assembly
HC-16	Q	22-00586	Speed Nut
HC-17	R	17-00101	Fibre Washer
HC-18	S	22-00158	Screw
HC-19	T	S-06-01007	Gear Box Assembly
HC-20	U	17-00090	Steel Washer
HC-21	V	S-03-00525	Motor Shaft Assembly
HC-22	W	22-00089	Screw
HC-23	X	22-00387	Screw
HC-24	Y	22-00560	Screw
HC-25	Z	17-00181	Lock Washer
HC-26	AA	43-00359B	Blade
HC-27	BB	43-00358A	Blade
HC-28	CC	06-00910	Adapter
HC-29	DD	17-00278	Washer
HC-30	EE	22-00474	Screw
HC-31	FF	S-06-00476AG	Cover
HC-32	GG	17-00411	Gasket
HC-33	HH	17-00005	Steel Washer
HC-34	II	S-01-01528	Drive Shaft
HC-35	JJ	10-00060	Ball
HC-36	KK	S-06-00911AG	Drive Housing Assembly (Includes Drive Shaft Bearing 9-20 and Motor Shaft Bearing 9-59)
HC-37	LL	17-00304	Felt Washer
HC-38	MM	22-00594	Screw
HC-39	NN	43-00378	Dust Shield
HC-40	PP	43-00398	Clamp
HC-41	QQ	22-00476	Screw
HC-42	RR	06-00909	Adapter



WEEDER CULTIVATOR (Continued)

Model HC 05

<u>Ref. No.</u>	<u>Ref. Letter</u>	<u>Part No.</u>	<u>Description</u>
HC-43	SS	43-00363CN	Handle, Lower Half
HC-44	TT	11-00090B	Cord Set
HC-45	UU	11-00088B	Cord Set
HC-46	VV	43-00364AA	Upper Guard
HC-47	WW	22-00616	Screw
HC-48	XX	17-00086	Lock Washer
HC-49	YY	AH-00-00022B	Handle
HC-50	ZZ	43-00394	Bridge
HC-51	AB	43-00400	Strap
HC-52	AC	43-00497CN	Handle, Upper Half
HC-53	AD	01-00932	Bottom Baffle
HC-54	AG	23-00115	Tape
HC-55	AH	43-00374	Motor Housing
HC-56	AI	05-00948POL	Cap
HC-57	AJ	22-00676	Screw
HC-58	AK	44-00229B	Handle Support
HC-59	AL	28-00095	Rubber Pad
HC-60	AN	18-00253	Switch
HC-61	AO	44-00230B	Handle Cover
HC-62	AR	11-00225	Cord Set
HC-63	AS	11-00226	Plug
HC-64	AT	23-00272	Insulator

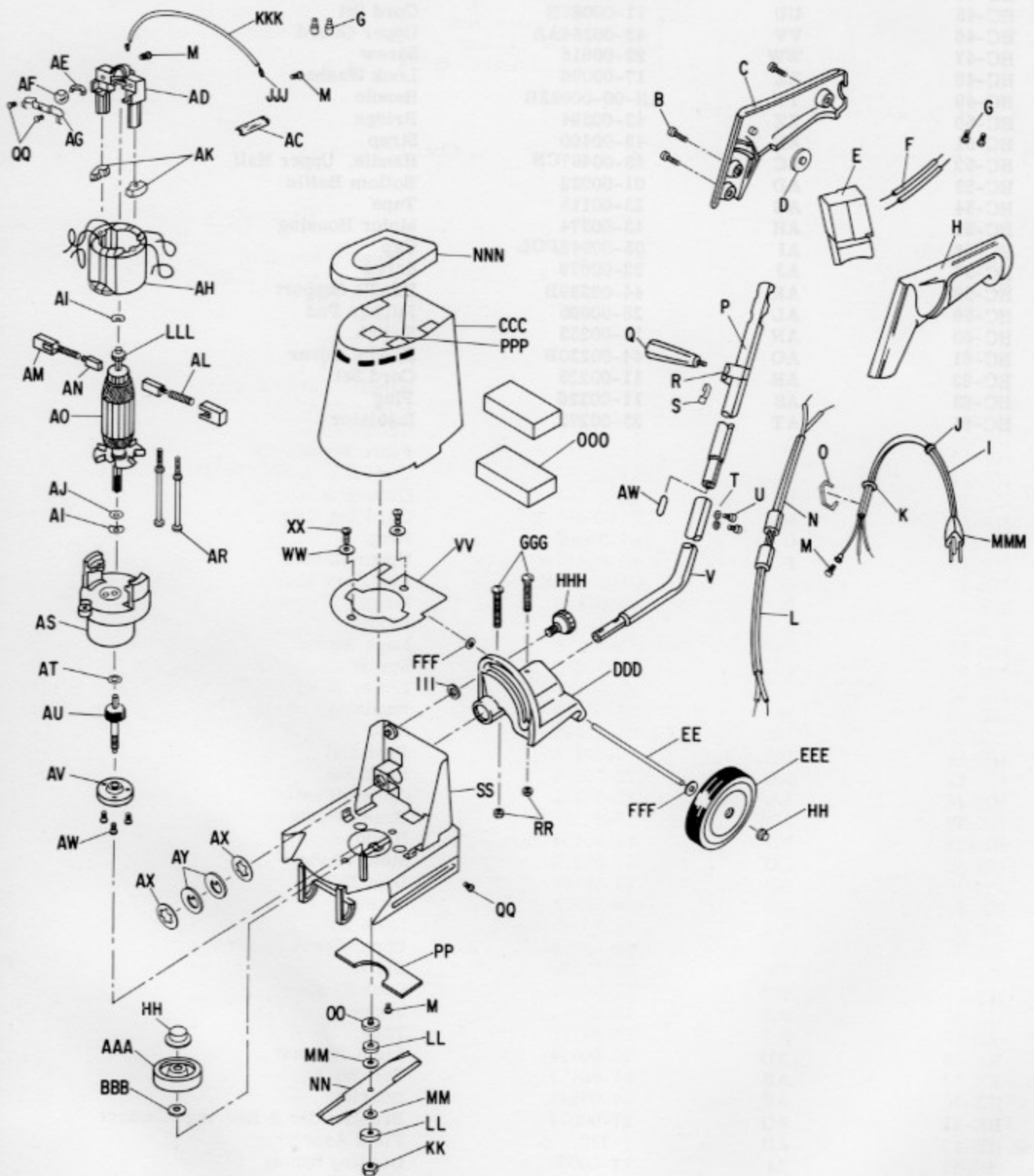

LAWN EDGER TRIMMER

Model HE 06

When ordering parts, always include part number, model number and full description.

Send orders direct to:

Mc Graw Edison  
Power Tool Division  
Parts and Service Dept.  
1501 East Main Street  
St. Charles, Illinois 60174

or call: Area Code (312) 584-1750

Minimum order is \$2.00 with terms of net 30 F.O.B., St. Charles, Illinois.

<u>Ref. No.</u>	<u>Ref. Letter</u>	<u>Part No.</u>	<u>Description</u>
HE-1	B	22-00676	Screw, 2 Required
HE-2	C	44-00229-B	Handle, Support Half
HE-3	D	28-00095	Rubber Pad
HE-4	E	18-00135	Switch
HE-5	F	39-00126	Lead Wire
HE-6	G	16-00004	Connector
HE-7	H	44-00230-B	Handle, Cover Half
HE-8	I	11-225	Power Cord
HE-9	J	28-00077	Grommet
HE-10	K	17-00312	Fibre Washer
HE-11	L	11-00089-B	Cord Set, Lower Portion
HE-12	M	22-00594	Ground Screw
HE-13	N	11-00088-B	Cord Set, Upper Portion
HE-14	O	01-00009	Ring
HE-15	P	43-00497-CN	Upper Handle
HE-16	Q	AH-00-00022-B	Auxiliary Handle
HE-17	R	43-00400	Strap
HE-18	S	43-00394	Bridge
HE-19	T	17-00086	Lock Washer
HE-20	U	22-00616	Screw
HE-21	V	43-00562-CN	Lower Handle
HE-22	W	23-00272	Insulator
HE-23	EE	01-01575	Axle
HE-24	HH	22-00781	Push Nut
HE-25	KK	22-00593	Lock Nut
HE-26	LL	17-00317	Clutch Washer
HE-27	MM	17-00266	Brass Washer
HE-28	NN	43-00494-BO	Blade
HE-29	OO	17-00279	Steel Washer
HE-30	PP	43-00341	Dust Shield
HE-31	QQ	22-00594	Screw
HE-32	RR	22-00615	Lock Nut
HE-33	SS	543-00486AE	Upper Guard Assembly
HE-34	VV	23-00276	Baffle
HE-35	WW	27-00092	Lock Washer
HE-36	XX	22-00426	Screw
HE-37	AC	23-00115	Tape
HE-38	AD	06-00474	Field Bracket
HE-39	AE	01-00452	Felt Wick
HE-40	AF	09-00044	Bearing
HE-41	AG	27-00054	Brushholder & Bearing Retainer
HE-42	AH	8-222	Field Assembly
HE-43	AI	27-00008	Loading Spring
HE-44	AJ	17-00101	Fibre Washer



LAWN EDGER TRIMMER (Continued)

Model HE 06

<u>Ref. No.</u>	<u>Ref. Letter</u>	<u>Part No.</u>	<u>Description</u>
HE-45	AK	44-00297	Spacer
HE-46	AL	14-00068	Brush Spring
HE-47	AM	14-00045	Brushholder
HE-48	AN	14-00046	Brush
HE-49	AO	7-217	Armature Assembly
HE-50	AR	22-00811	Screw
HE-51	AS	S6-1007	Gear Box Assembly
HE-52	AT	17-00090	Steel Washer
HE-53	AU	S-02-00294	Spindle Shaft Assembly
HE-54	AV	09-00101	Bearing
HE-55	AW	23-00272	Insulator
HE-56	AX	01-00931	Retaining Ring
HE-57	AY	17-00301	Washer
HE-58	AAA	44-00227	Roller
HE-59	BBB	17-00290	Washer
HE-60	CCC	43-368AR	Motor Housing
HE-61	DDD	6-1011AR	Wheel Bracket
HE-62	EEE	44-00264	Wheel
HE-63	FFF	17-00194	Washer
HE-64	GGG	22-00822	Screw
HE-65	HHH	AH-00-00037-B	Knob
HE-66	III	17-00421	Spacer
HE-67	JJJ	16-00021	Terminal
HE-68	KKK	539-00127	Lead
HE-69	LLL	17-00100	Washer
HE-70	MMM	11-226	Plug
HE-71	NNN	5-948-AS	End Cap
HE-72	OOO	1-1525	Filter
HE-73	PPP	22-586	Speed Nut

Part No.	Part Name	Part No.	Part Name
16-0001	Motor Housing	16-0002	Motor Housing
16-0003	Motor Housing	16-0004	Motor Housing
16-0005	Motor Housing	16-0006	Motor Housing
16-0007	Motor Housing	16-0008	Motor Housing
16-0009	Motor Housing	16-0010	Motor Housing
16-0011	Motor Housing	16-0012	Motor Housing
16-0013	Motor Housing	16-0014	Motor Housing
16-0015	Motor Housing	16-0016	Motor Housing
16-0017	Motor Housing	16-0018	Motor Housing
16-0019	Motor Housing	16-0020	Motor Housing
16-0021	Motor Housing	16-0022	Motor Housing
16-0023	Motor Housing	16-0024	Motor Housing
16-0025	Motor Housing	16-0026	Motor Housing
16-0027	Motor Housing	16-0028	Motor Housing
16-0029	Motor Housing	16-0030	Motor Housing
16-0031	Motor Housing	16-0032	Motor Housing
16-0033	Motor Housing	16-0034	Motor Housing
16-0035	Motor Housing	16-0036	Motor Housing
16-0037	Motor Housing	16-0038	Motor Housing
16-0039	Motor Housing	16-0040	Motor Housing
16-0041	Motor Housing	16-0042	Motor Housing
16-0043	Motor Housing	16-0044	Motor Housing
16-0045	Motor Housing	16-0046	Motor Housing
16-0047	Motor Housing	16-0048	Motor Housing
16-0049	Motor Housing	16-0050	Motor Housing
16-0051	Motor Housing	16-0052	Motor Housing
16-0053	Motor Housing	16-0054	Motor Housing
16-0055	Motor Housing	16-0056	Motor Housing
16-0057	Motor Housing	16-0058	Motor Housing
16-0059	Motor Housing	16-0060	Motor Housing
16-0061	Motor Housing	16-0062	Motor Housing
16-0063	Motor Housing	16-0064	Motor Housing
16-0065	Motor Housing	16-0066	Motor Housing
16-0067	Motor Housing	16-0068	Motor Housing
16-0069	Motor Housing	16-0070	Motor Housing
16-0071	Motor Housing	16-0072	Motor Housing
16-0073	Motor Housing	16-0074	Motor Housing
16-0075	Motor Housing	16-0076	Motor Housing
16-0077	Motor Housing	16-0078	Motor Housing
16-0079	Motor Housing	16-0080	Motor Housing
16-0081	Motor Housing	16-0082	Motor Housing
16-0083	Motor Housing	16-0084	Motor Housing
16-0085	Motor Housing	16-0086	Motor Housing
16-0087	Motor Housing	16-0088	Motor Housing
16-0089	Motor Housing	16-0090	Motor Housing
16-0091	Motor Housing	16-0092	Motor Housing
16-0093	Motor Housing	16-0094	Motor Housing
16-0095	Motor Housing	16-0096	Motor Housing
16-0097	Motor Housing	16-0098	Motor Housing
16-0099	Motor Housing	16-0100	Motor Housing

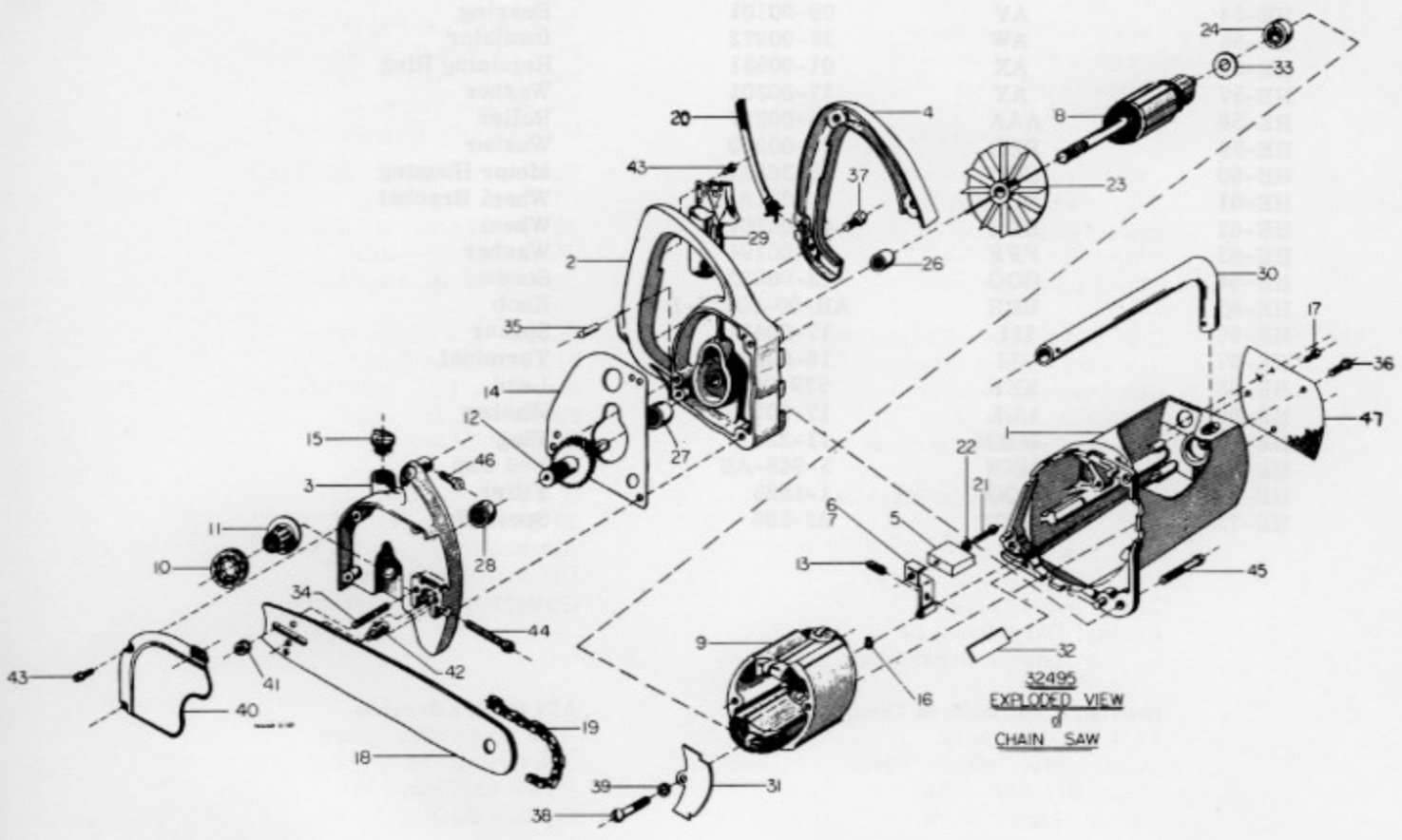

**CHAIN SAW**

Model HS13

When ordering parts, always specify the quantity, model number part number and description.

Send orders direct to the nearest Generac Service Central listed below:

Southern Jack Company  
613 North 9th Street  
Birmingham, Alabama 35203  
Phone 205/254-3830  
Contact Tim O'Brien

Lakeside Repair Shop  
4112 W. McCollum Lake Road  
McHenry, Illinois 60050  
Phone 815/385/3131  
Contact Bob Peterson

VBT Supply Co.  
1729 Country Club Place  
Indianapolis, Indiana 46224  
Phone 317/248-1441  
Contact Bob Schneck

Iowa Automotive Electric Service  
215 East Walnut Street  
Des Moines, Iowa  
Phone 515/288-7624  
Contact Dennis Hammond

Beerman Precision Machine Works  
P. O. Box 53432  
2121 Thalia Street  
New Orleans, La. 70153  
Phone 504/581-1998  
Contact Gary Jones or  
Lester Bourgeois

Northern Automotive Company  
1401 W. Broadway  
Minneapolis, Minn. 55401  
Phone 612/522-6656  
Contact Larry Stack

Guarantee Electrical Company  
4161 Gravois Street  
St. Louis, Mo. 63116  
Phone 314/664-4910  
Contact John Steffenow

Fairfield Power Company  
834 Fairfield  
Kenilworth, N. J. 07033  
Phone 201/241-4099  
Contact Jim Richards

Generfur Power Company  
331 Waverly Avenue  
Mamaroneck, New York 10543  
Phone 914/698-8325  
Contact Stanley Kolt

Transmission Parts  
2195 Commercial St., N. E.  
Salem, Oregon 97301  
Phone 503/364-6194  
Contact Mr. Ray Benson

Havis and Shields Automotive  
10 North York Road  
Willow Grove, Pa. 19090  
Phone 215/659-0108  
Contact W. H. Mechanic

Babine Electric Service, Inc.  
315 Jefferson Blvd.  
Warwick, R. I. 02888  
Phone 401/738-0333  
Contact Edward Babine

D & S Repair Service  
20 South Dove Street  
Alexandria, Va. 22314  
Phone 703/683-0009  
Contact Andy Saulnier

AFI Direct Service  
7515 South 10th Street  
Oak Creek, Wi. 53154  
Phone 414/764-1160  
Contact Dave Gralewics

Fred Hogle and Company Ltd.  
3445 Cote Vertu Rd.  
Montreal 382, Quebec  
Phone 514/336-4330  
Contact Ian Ross or  
Andre Courte

Dealers should identify themselves to Service Centrals as "General Electric Elec-Trak" dealers for receipt of applicable discounts.

There is a minimum order of \$5.00 with terms of 1% 10 days, net 30 F. O. B. Service Central.



<u>Ref. No.</u>	<u>Part No.</u>	<u>Description</u>	<u>Price</u>
1	32461	Motor Housing	\$ 7.65
2	32463	Center Section	10.12
3	32465	Front Housing	19.40
4	32467	Handle, Chain Saw	2.65
5	32476	Brush	2.06
6	32475	Brush Holder, R. H.	2.41
7	32474	Brush Holder, L. H.	2.42
9	32347	Field Assembly	17.30
10	32480	Sprocket	3.85
11	32483	Drive Hub	5.19
12	32655	Idler Shaft Assembly	8.15
13	32487	Brush Holder Spring	0.20
14	32468	Gasket, Chain Saw	0.27
15	32479	Oil Cap	0.47
16	32491	Snap Ring #5555-1	0.11
17	22774	Sheet Metal Screw #8 x 3	0.10
18	32477	Chain Bar, 13-inch	27.52
19	32478	Chain for 13-inch Saw	14.07
20	32489	Cord Assembly	48.34
21	26713	RHMSB #6-32 x 1 1	0.27
23	25174	Fan	1.37
24	25177	Bearing #6200PR	3.68
26	25229	Bearing, Bronze	0.73
27	25230	Bearing, Bronze	0.47
28	25231	Bearing, Bronze	1.58
29	25238	Switch, Trigger	5.01
30	26277	Handle, Tubular	6.87
31	26796	Air Deflector	0.50
32	26849	Wire Hold Down TA	0.15
33	27139	Flat Washer 13/32	0.26
34	25751	Stud 5/16 x 1 1/4	0.81
37	24611	Taptite, #10 x 1	0.11
38	22151	RHMS #10-32 x 2 1	0.15
39	22769	Shakeproof Int. #10	0.10
40	32500	Chain Guard	4.42
41	32499	Flanged Nut, 5/16-	0.27
42	32486	Adjusting Nut	0.60
43	26902	Taptite #8-32 x 1	0.10
44	28409	SHC 1/4-20 x 1 3/	0.60
45	27117	Taptite 1/4-20 x	0.22
46	24489	Taptite, #10 x 3/8	0.10
47	32482	Rear Screen	2.58
48	34919	Drive Rim Retainer	1.28

TOP VIEW

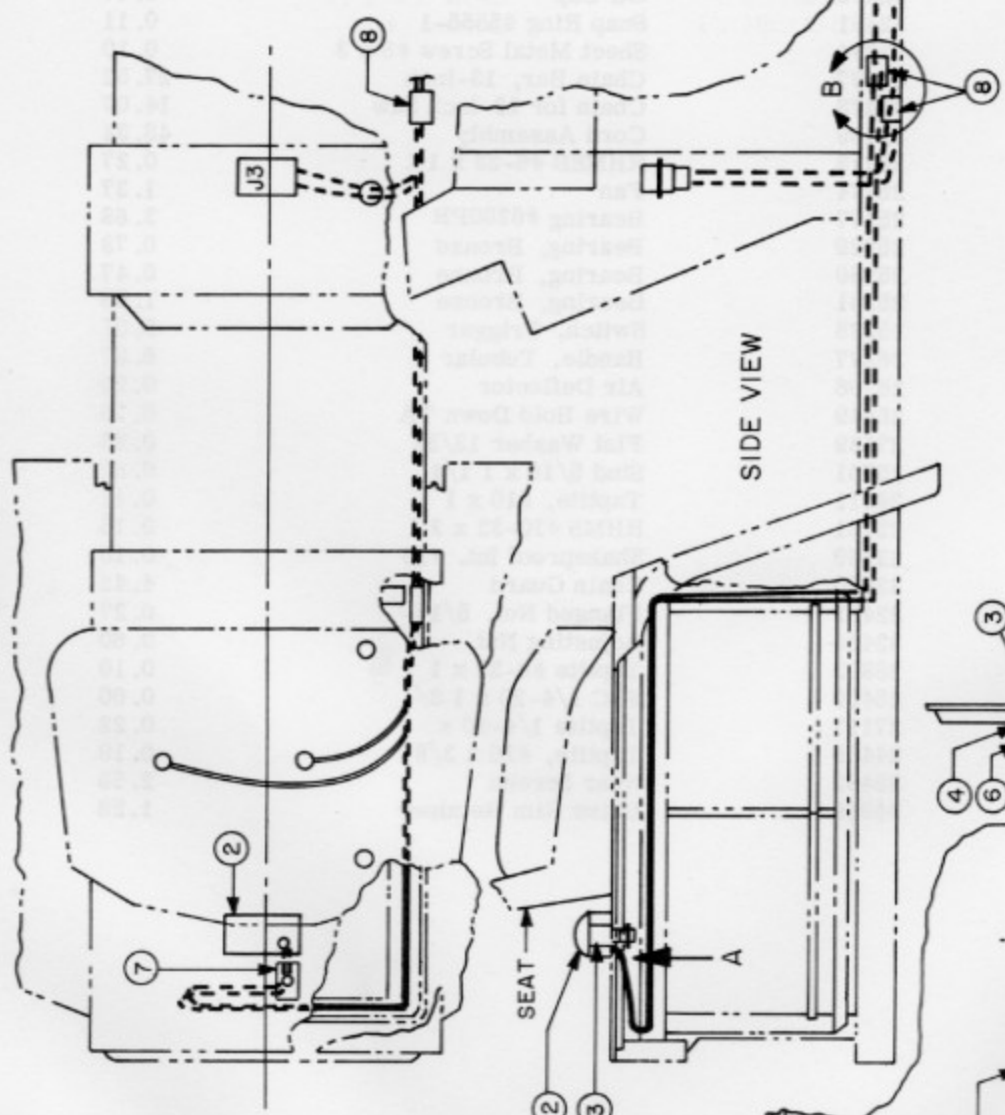

SIDE VIEW

VIEW B (ENLARGED)

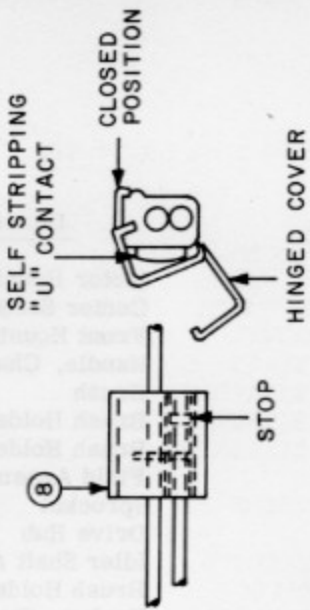

B

CLOSED POSITION

SELF STRIPPING "U" CONTACT

HINGED COVER

STOP

TO HEAD LIGHTS

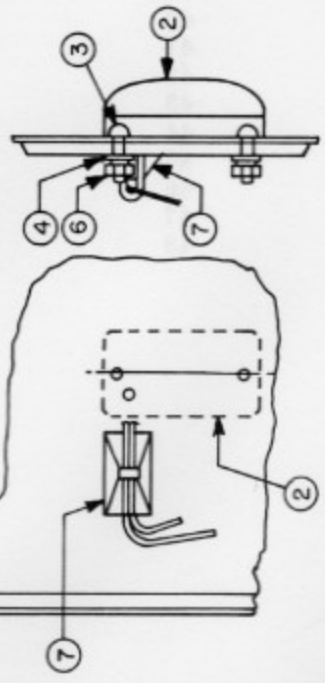

VIEW AT A

# TAIL LIGHT KIT

AP70

<u>Ref. No.</u>	<u>Part No.</u>	<u>Description</u>
1	178B8025G1	Mod. #26AP70AA
2	178B8004G2 includes: 211A3592P2 243A4804P1 243A4805P1 243A4803P2	Tail Light Asm. Lamp Lens Gasket Base
3	N37P15014B6	Slotted Round Hd. Mach. Screw #8-32 x 7/8 Lg.
4	N402AP8B6	Plain Washer #8 Narrow
5	N405P8C6	Spring Lockwasher #8
6	N210P15B6	Hex. Mach. Screw Nut #8-32
7	243A4840P1	Cable Tie & Base
8	243A4841P1	Connector

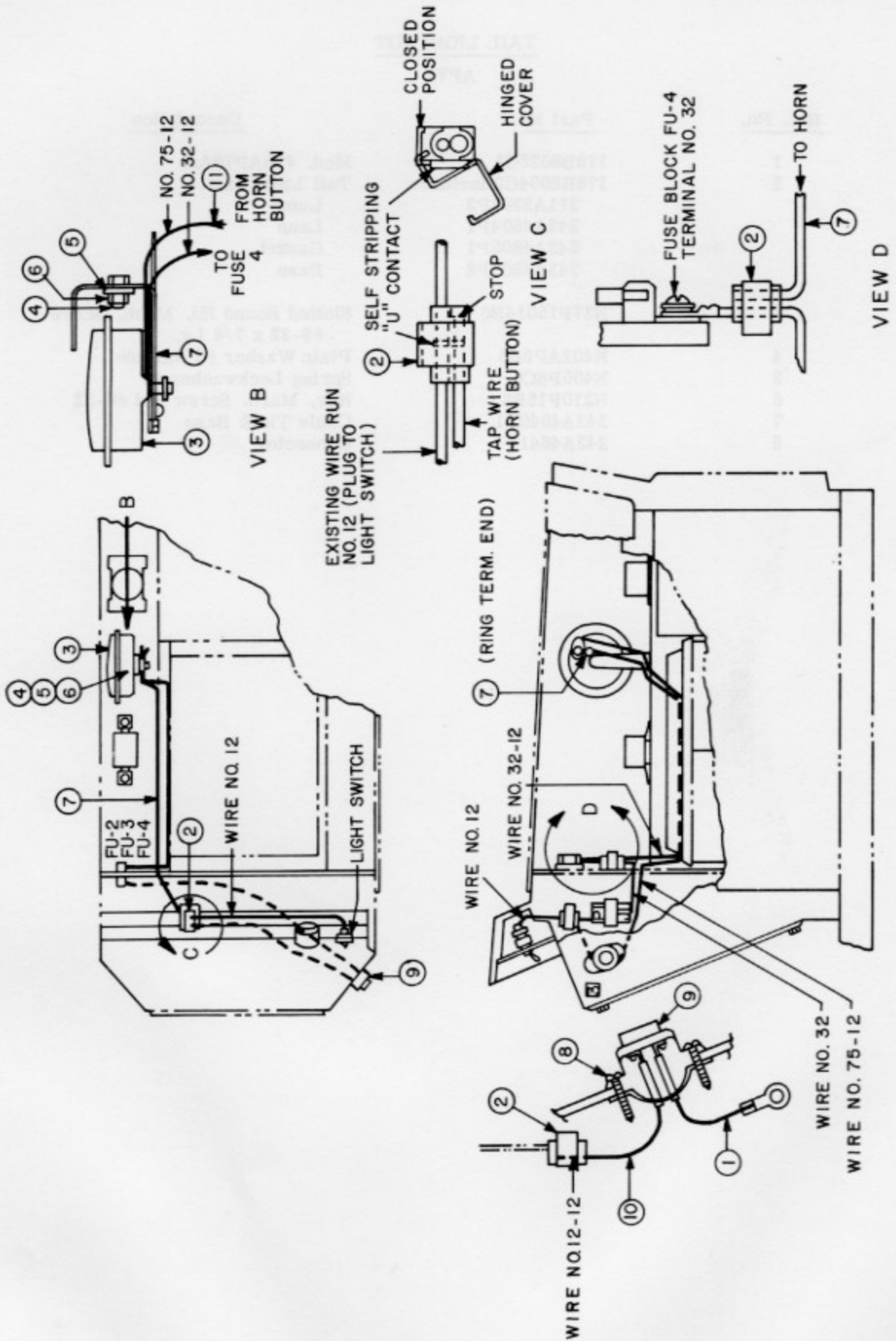

TRACTOR HORN KIT

AP69

<u>Ref. No.</u>	<u>Part No.</u>	<u>Description</u>
1	178B8051G1	Horn Kit
2	243A4841P1	Connector
3	243A4883P1	Horn
4	N22P25012B6	Hex. Hd. Bolt (7) #3/8-16 x 0.75
5	N405P13C6	Spring Lockwasher (7) #3/8
6	N210P25B6	Nut, Hex. (7) #3/8-16
7	243A4882G3	Wire Asm. (7) #32-12
8		For Tractor Horn Kit
9	243A4881P1	Horn Button
10	243A4882G1	Wire Asm., #12-12 (14, 6)
11	243A4882G2	Wire Asm., #75-12 (14, 7)

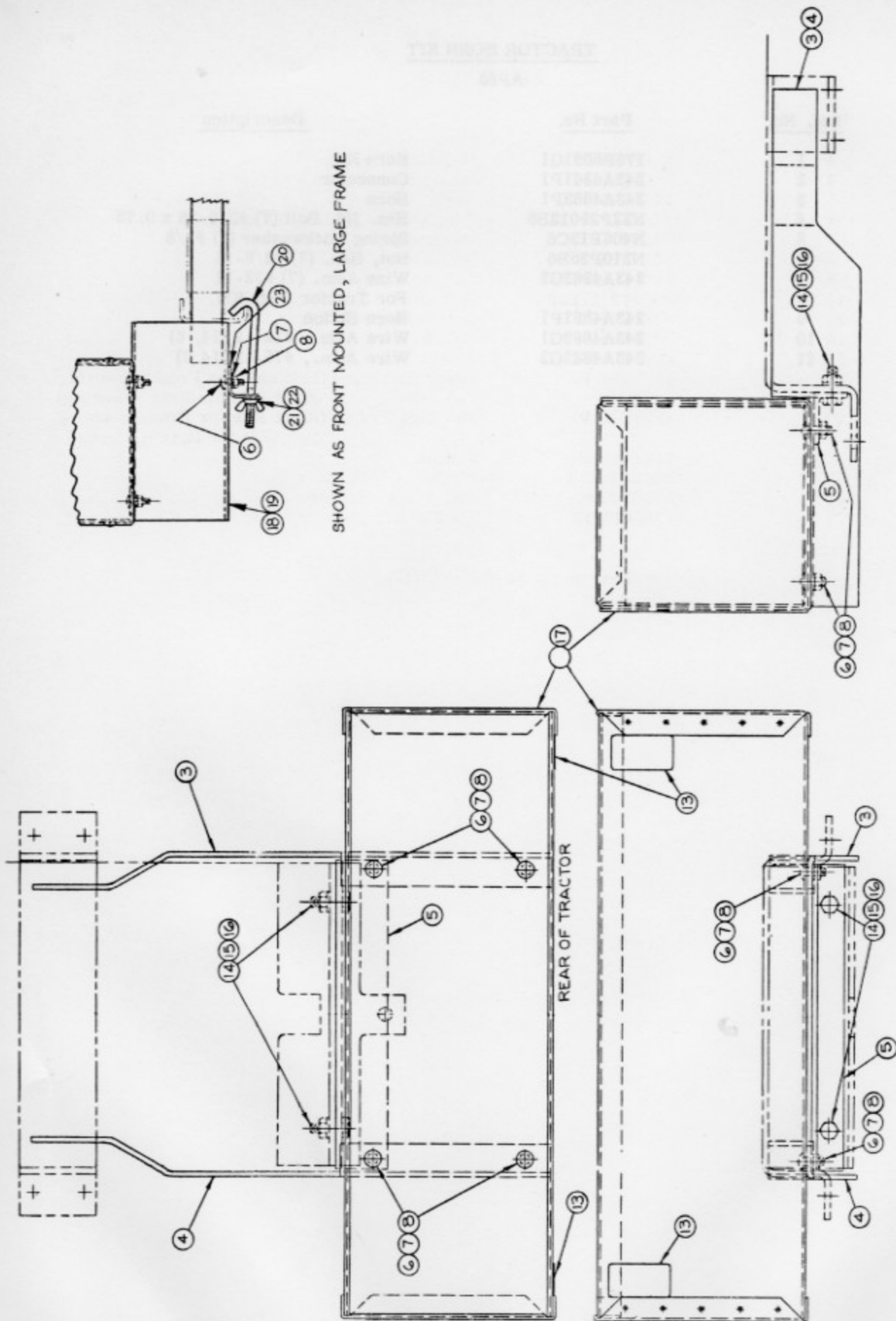

SHOWN AS FRONT MOUNTED, LARGE FRAME

DUAL USE WEIGHT BOX  
AP85/AP86

<u>Ref. No.</u>	<u>Part No.</u>	<u>Description</u>
3	178B8315P1	Mounting Bracket
4	178B8315P2	Mounting Bracket
5	244A7468P1	Angle
6	*N657P23016B6	Carriage Bolt - 5/16-18 x 1 In.
7	*N403P31C6	Lockwasher - 5/16 In.
8	*N258P23B6	Nut, Hex - 5/16-18
13	243A4870P1	Tail Reflector
14	*N657P21012B6	Bolt, Hex - 3/8-16 x 1-1/4 In.
15	*N405P73C6	Lockwasher - 3/8 In.
16	*N258P25B6	Nut, Hex - 3/8-16
17	155C8179G2	Weight Box
18	155C8089P2	Mounting Frame (Left side for Front mounting, Right side for Rear mounting)
19	155C8089P1	Mounting Frame (Right side for Front mounting, Left side for Rear mounting)
20	244A7219P1	J-Hook
21	*N402AP44B6	Washer - 7/16 In.
22	*N236P25B6	Nut, Wing - 3/8-16
23	178B8192P1	Tie Down Angle

\*Purchase small quantities locally.

**NOTE**

**SPINDLES ARE USED WITH BUCKET  
LOADER AND ARE DESIGNED FOR  
AXLES 178B8032 & 541C685**

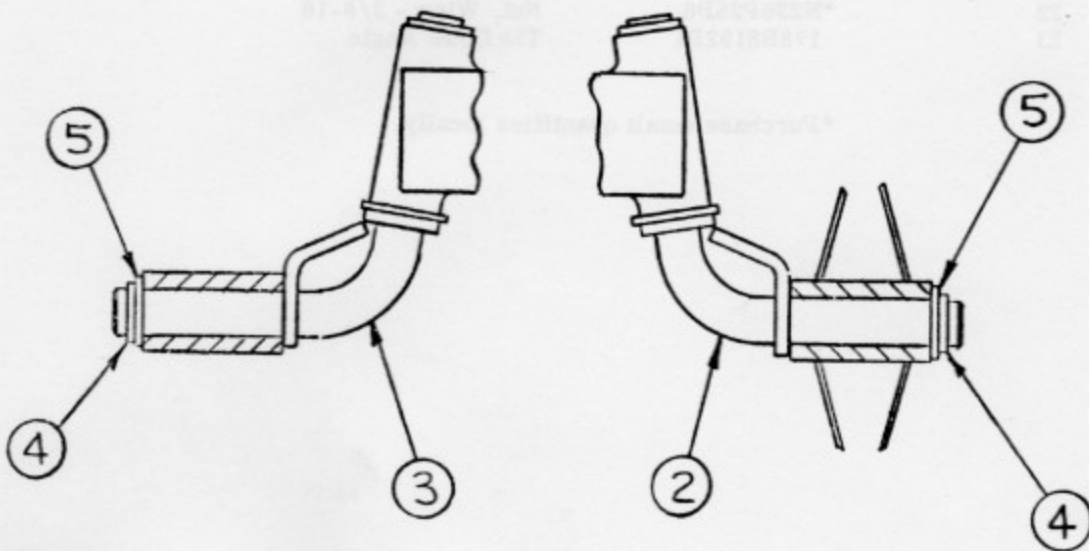

# H. D. SPINDLE KIT

Model KS-70

<u>Ref. No.</u>	<u>Part No.</u>	<u>Description</u>
2	178B8491G2	Spindle, Left
3	178B8490G2	Spindle, Right
4	*N922P75C6	Snap Ring, H. D.
5	*N402AP18B6	Washer, Plain 3/4 in. narrow

\* Purchase small quantities locally.

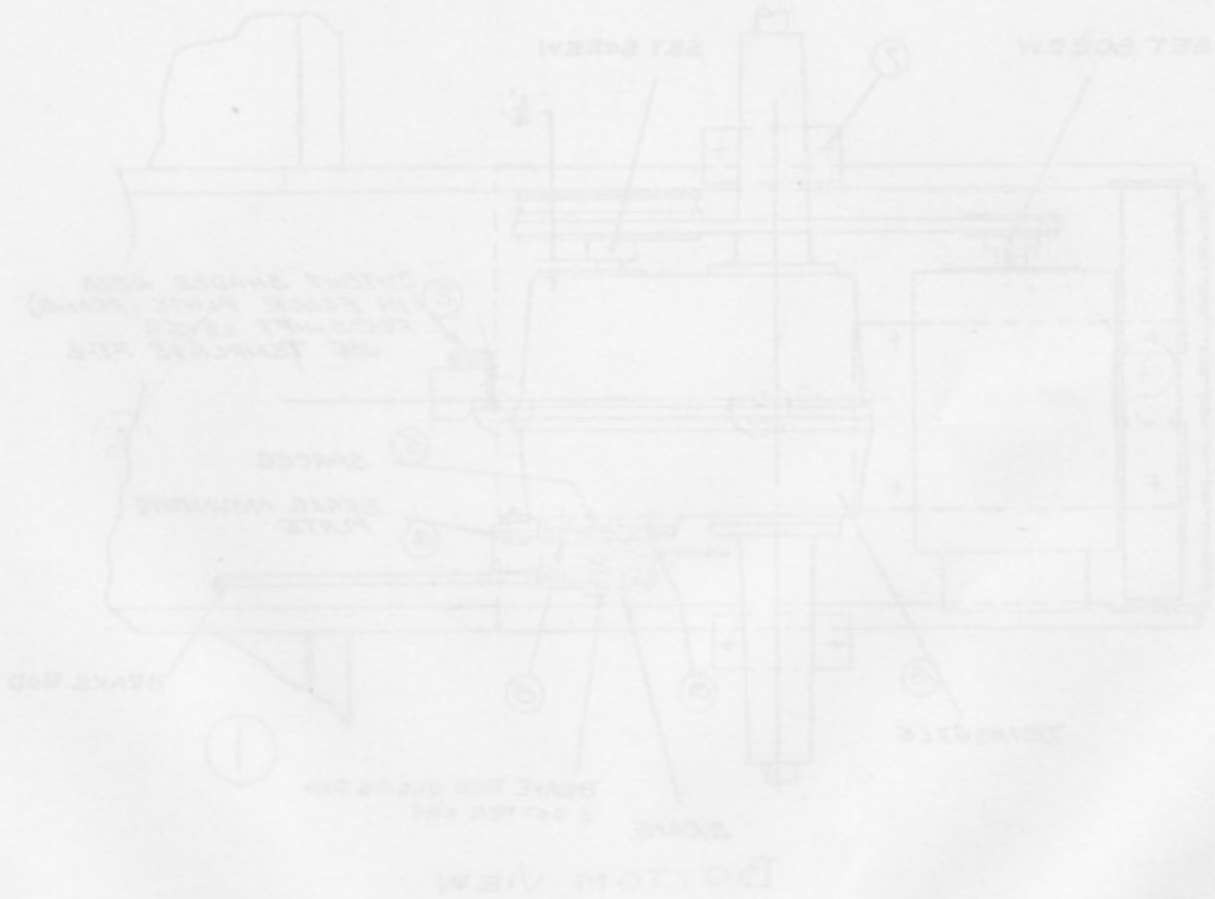

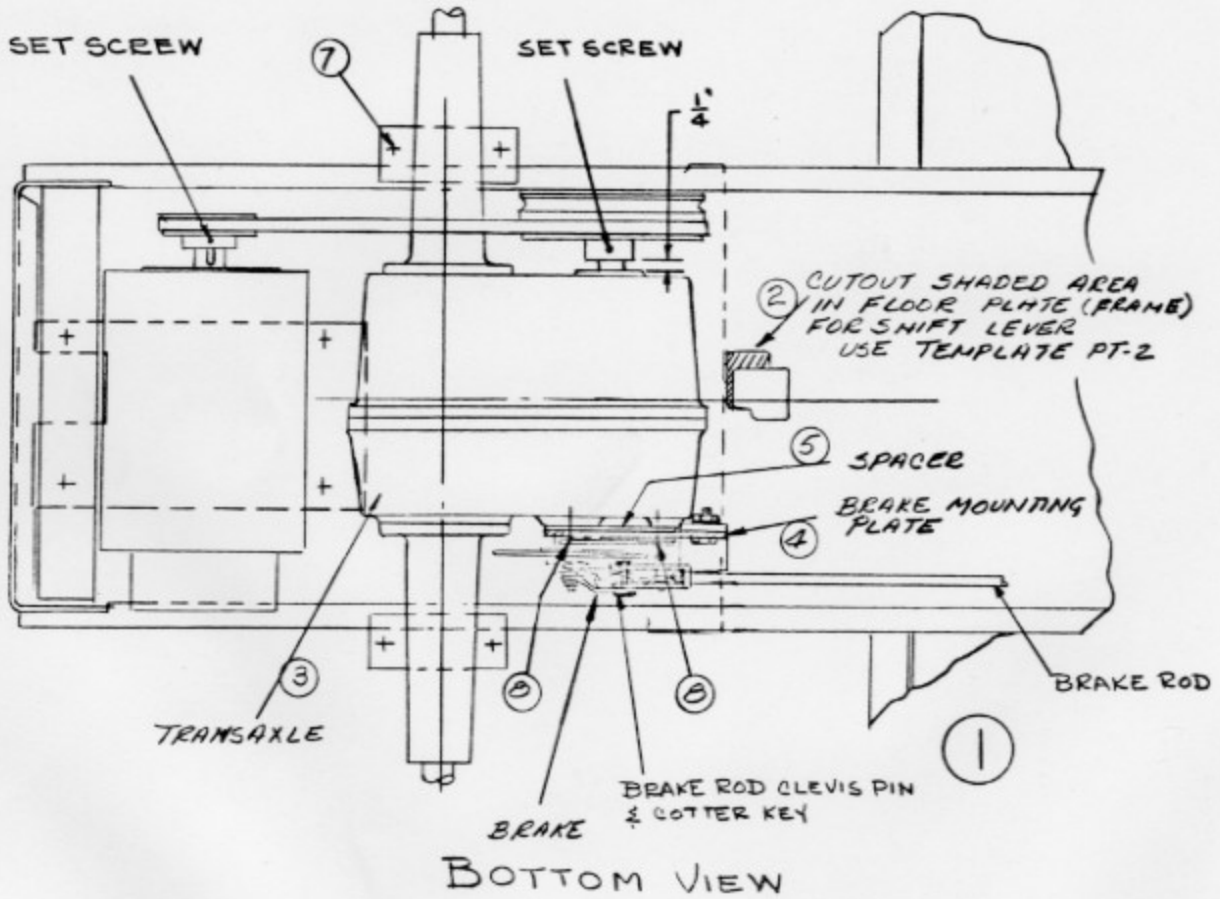
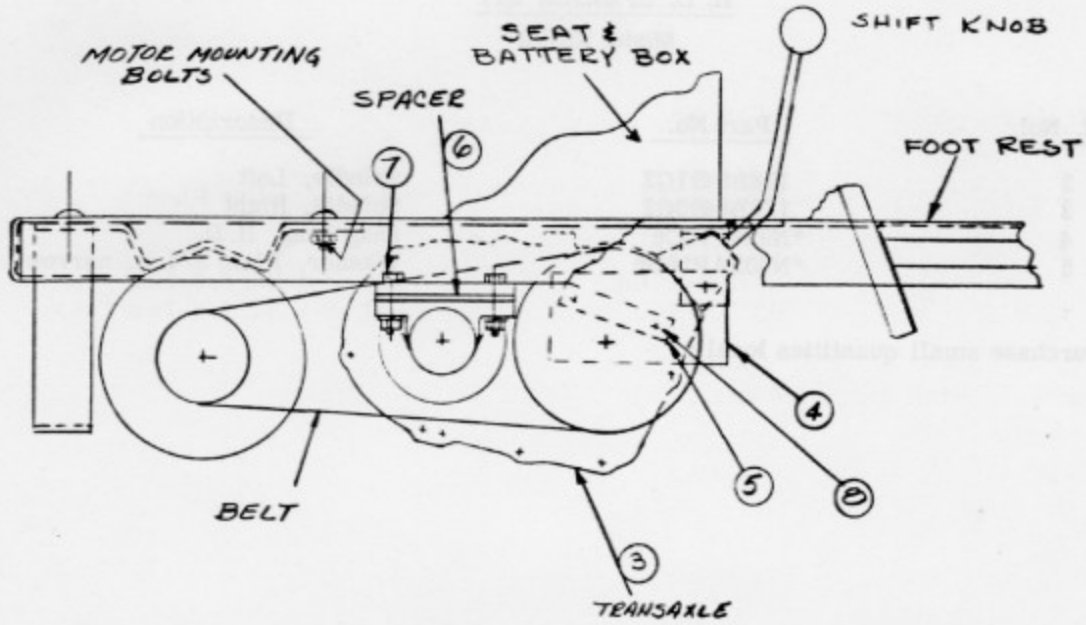

H. D. TRANSAXLE KIT (E12M)

Model KM-12

<u>Ref. No.</u>	<u>Part No.</u>	<u>Description</u>
3	422D818P1	Transaxle
4	244A7457P1	Brake Mounting Plate
5	244A7459P1	Spacer
6	244A7132P2	Block
7	*N22P25032B6	Bolt, Hex Hd. 3/8-16 x 2 inch
8	*N22P25016B6	Bolt, Hex Hd. 3/8-16 x 1 inch

\* Purchase small quantities locally.

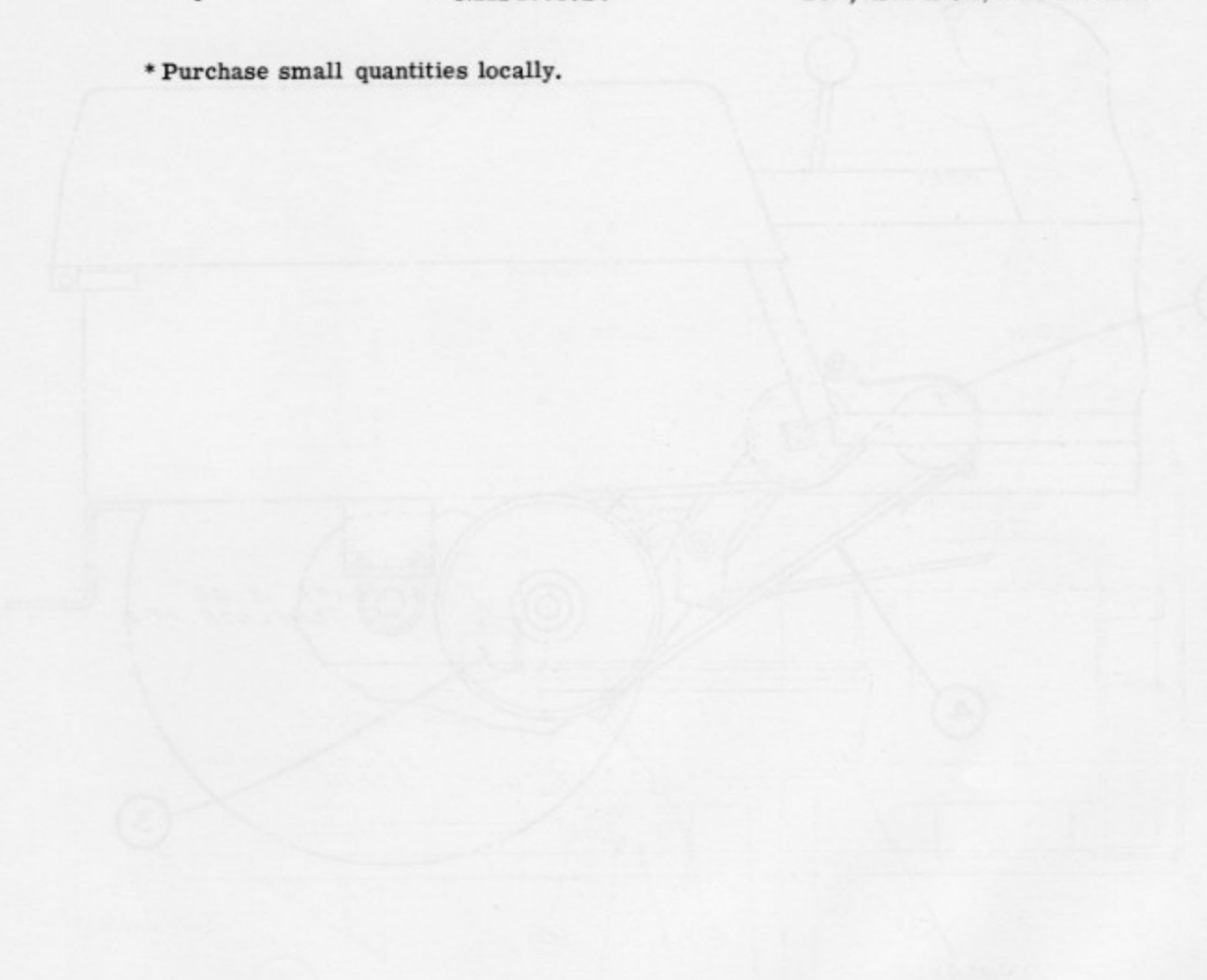

W. A. TRANSMISSION KIT (1970)

Model 100-10

Description

Part No.

Qty.

Transmission  
Gear Housing Plate  
Cover  
Shaft  
Roll. Bar Mt. 7/8-18 x 3 Inch  
Roll. Bar Mt. 1/2-20 x 1 Inch

422191001  
422191002  
422191003  
422191004  
422191005  
422191006  
422191007

1  
1  
1  
1  
1  
1  
1

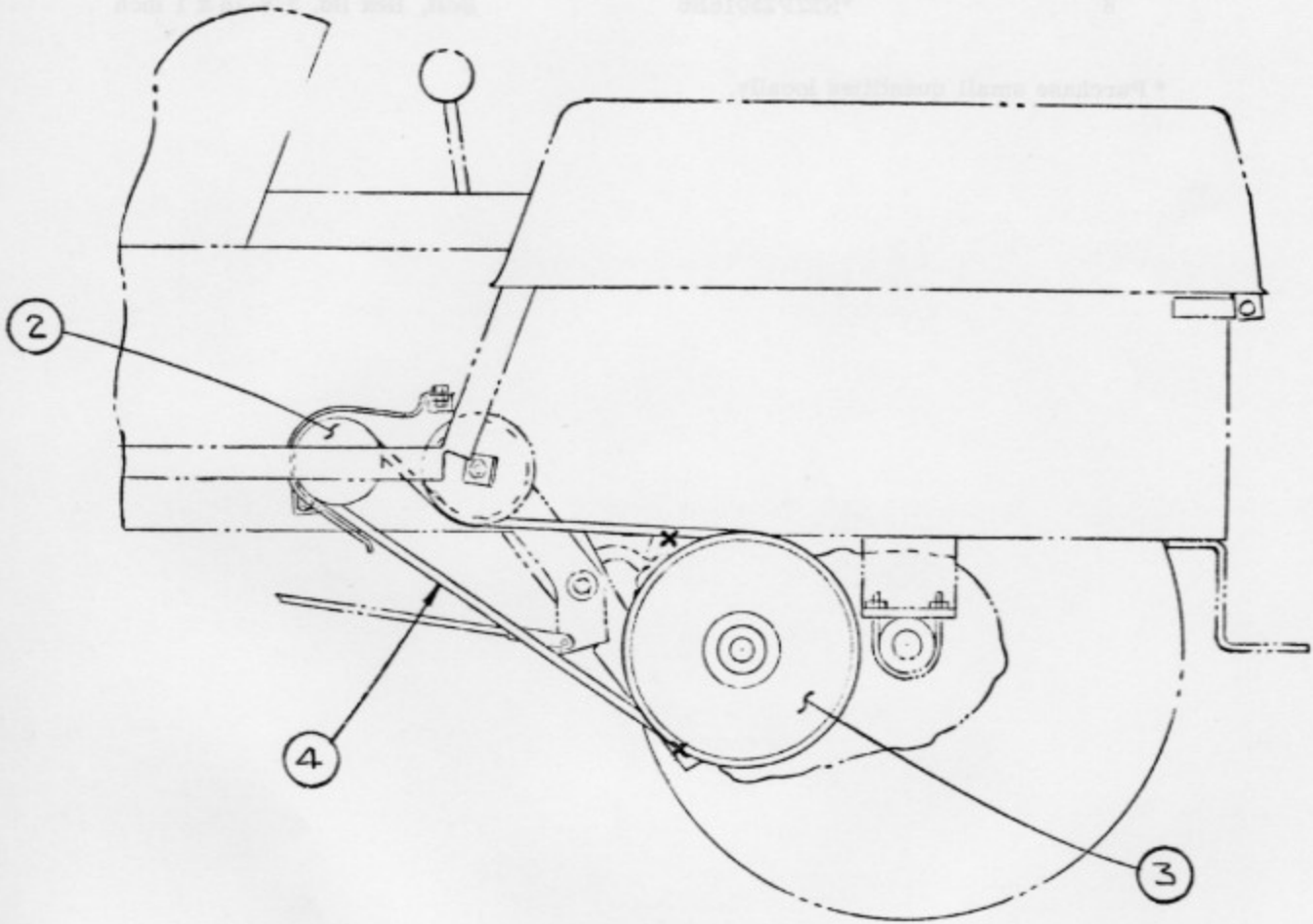

SPEED REDUCTION KIT

Model KD-38

<u>Ref. No.</u>	<u>Part No.</u>	<u>Description</u>
2	247A7357P1	Pulley
3	247A7358P1	Pulley
4	211A3226P12	Belt

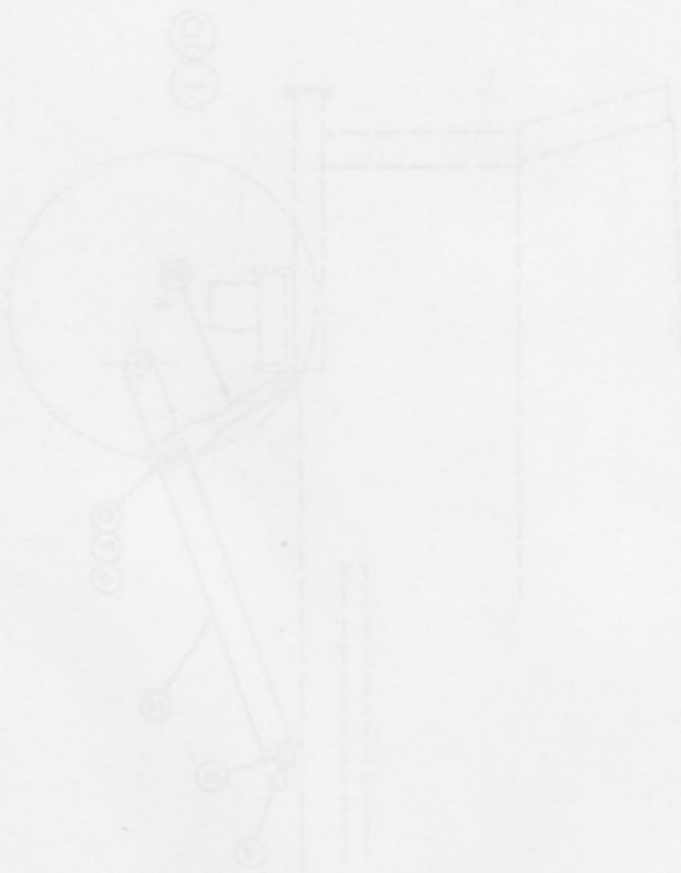
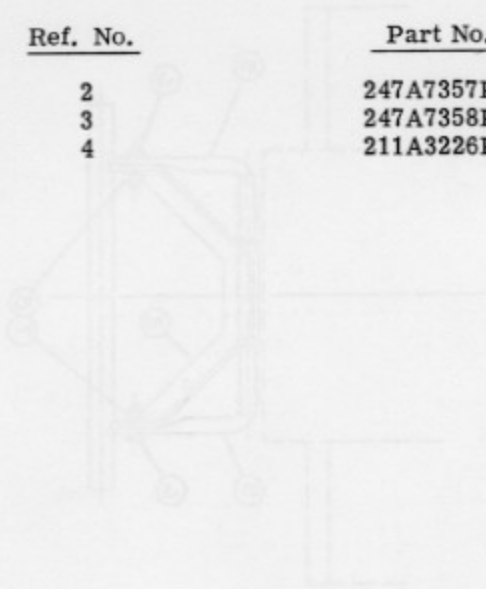

STAMP MOUNTING KIT  
Model X12-10

Direction  
Switch  
Taper  
Ball

Part No.  
SWITCH  
TAPER  
BALL

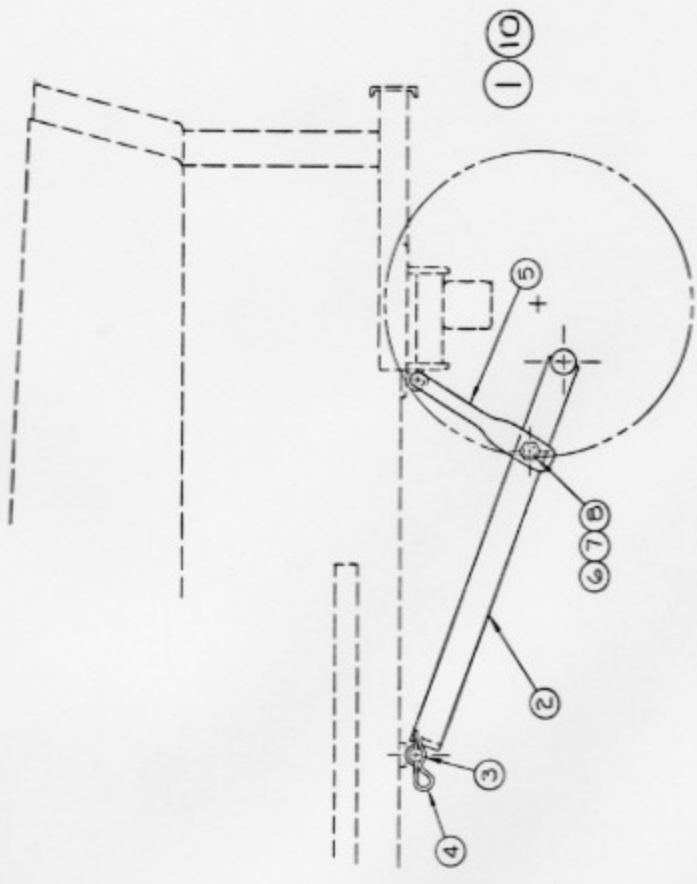
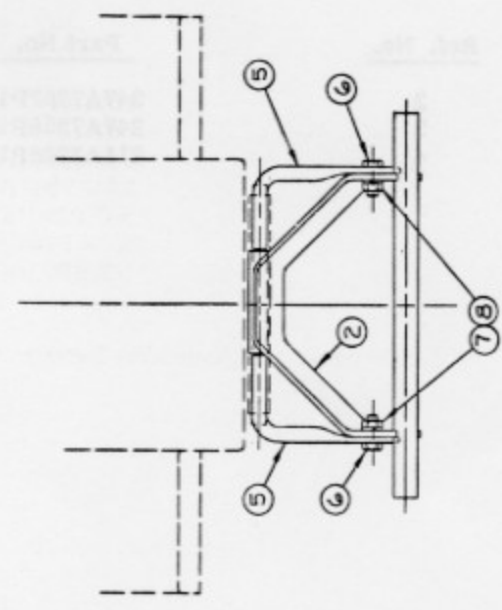
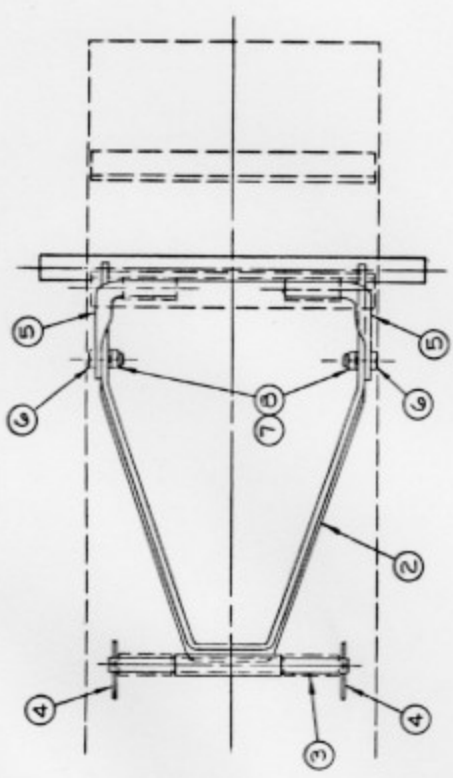

IMPLEMENT MOUNTING BRACKET ASSEMBLY

Model AP-54

<u>Ref. No.</u>	<u>Part No.</u>	<u>Description</u>
2	155C8143G1	Implement mounting bracket
3	244A7395P1	Shaft
4	243A4543P3	Hair Pin Cotter
5	244A7367P1	Support
6	*N22P29016B6	Bolt, Hex Hd. 1/2-13 x 1 inch
7	*N405P15L6	Lockwasher 1/2 inch
8	*N258P29B6	Nut, Hex 1/2-13

\* Purchase small quantities locally.

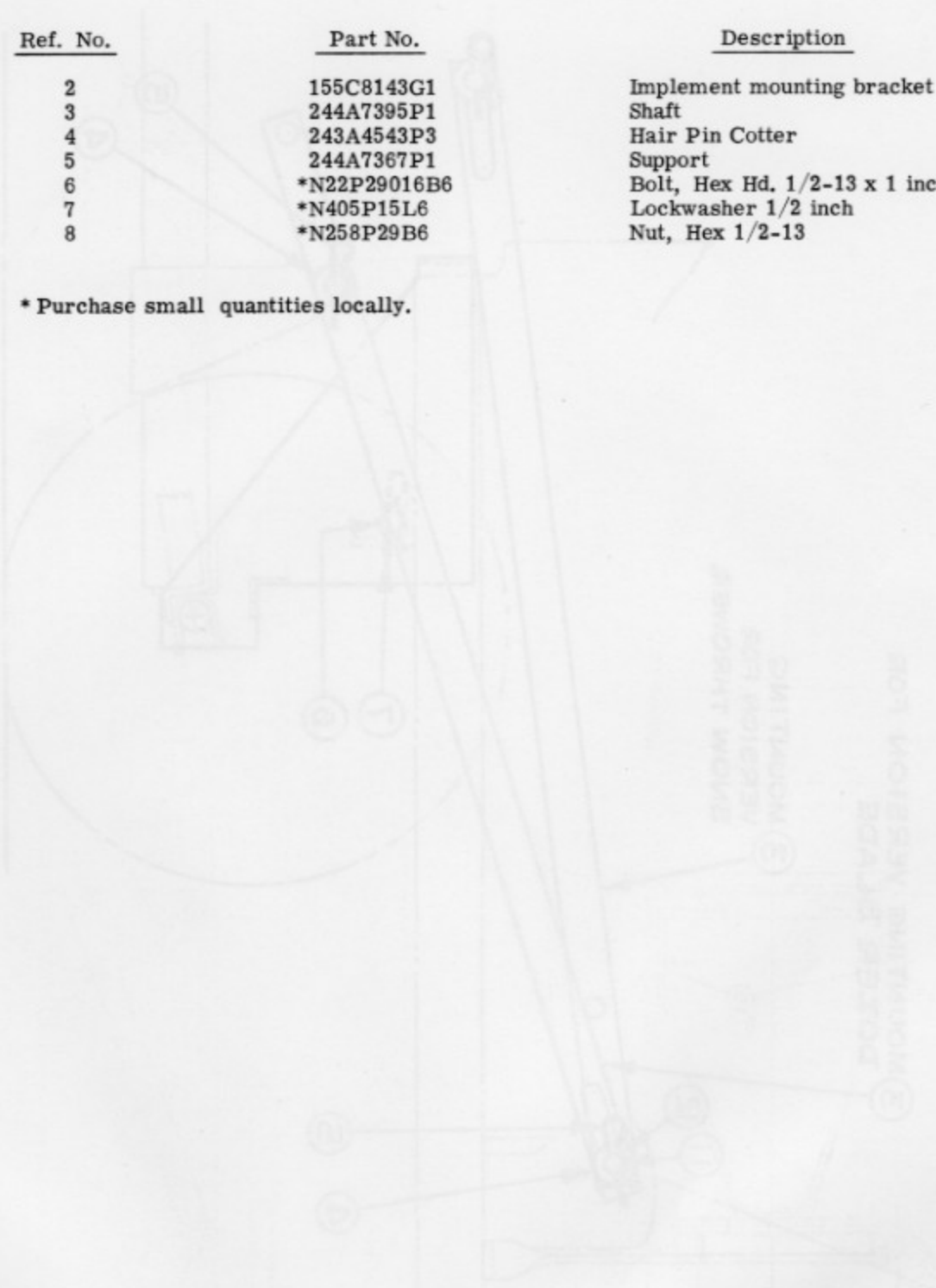

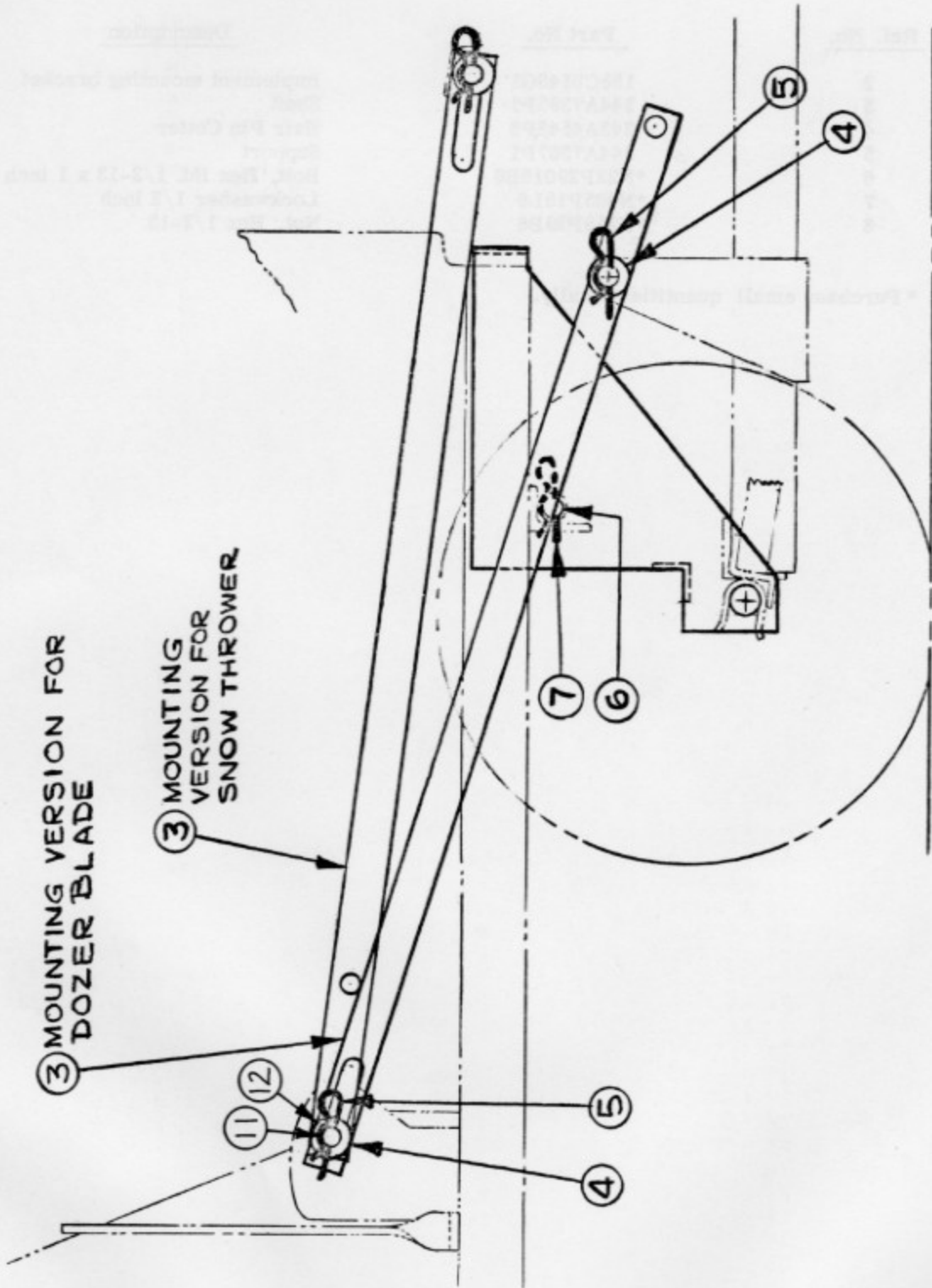

IMPLEMENT MOUNTING BRACKET AND LIFT BAR KIT

Model AP-55

<u>Ref. No.</u>	<u>Part No.</u>	<u>Description</u>
3	244A7223P1	Connecting Lift Bar
4	*N402AP45B6	Washer 1/2 inch
5	243A4543P1	Hair Pin Cotter
6	211A3505P16	Clevis Pin
7	243A4543P3	Hair Pin Cotter
11	211A3505P20	Clevis Pin
12	*N402AP15B6	Washer, Plain 1/2 inch narrow

\* Purchase small quantities locally.

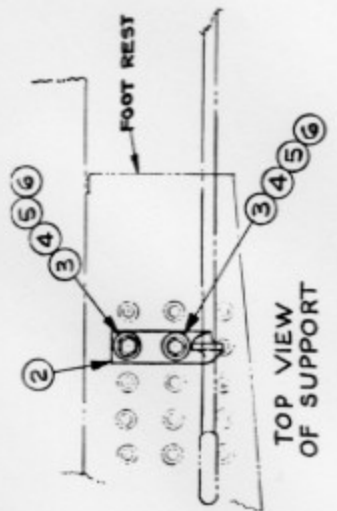

TOP VIEW OF SUPPORT

TOP VIEW OF SPRING BRACKET

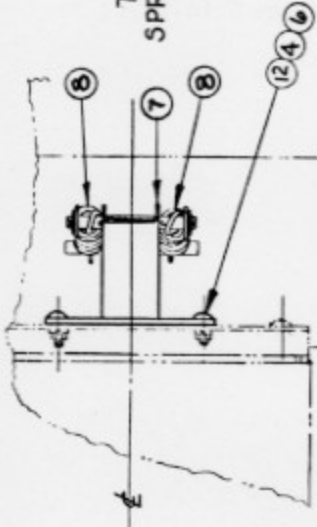

TOP VIEW OF HOOK BOLT

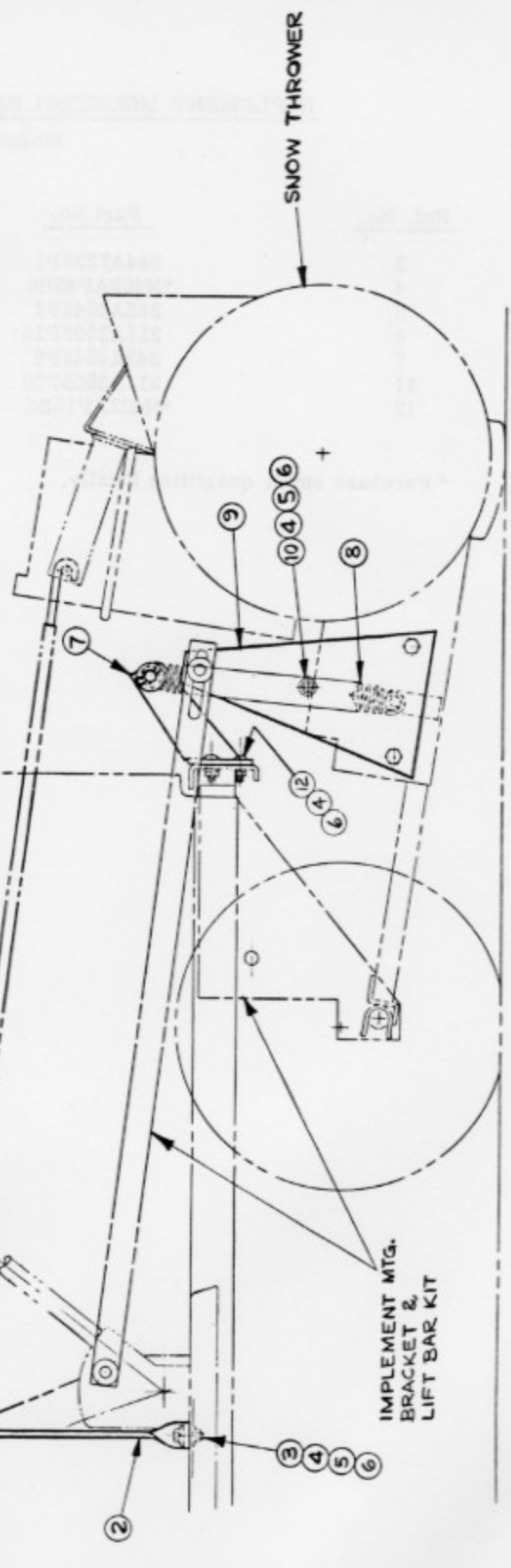
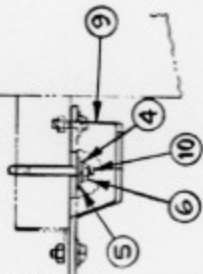

SNOW THROWER ADAPTER KIT

Model KD-42

<u>Ref. No.</u>	<u>Part No.</u>	<u>Description</u>
2	178B8177P1	Support
3	*N22P23014B6	Bolt, Hex. Hd. 5/16-18 x 7/8 inch
4	*N405P12C6	Lockwasher 5/16 inch
5	*N402AP42B6	Washer, Plain 5/16 inch
6	*N402P23B6	Nut, Hex 5/16-18
7	178B8194G1	Spring Bracket
8	244A7245P1	Spring
9	244A7218G1	Bracket Assembly
10	244A7217P1	Hook Bolt
12	*N657P23016B6	Bolt, Carriage 5/16-18 x 1 inch

\* Purchase small quantities locally.

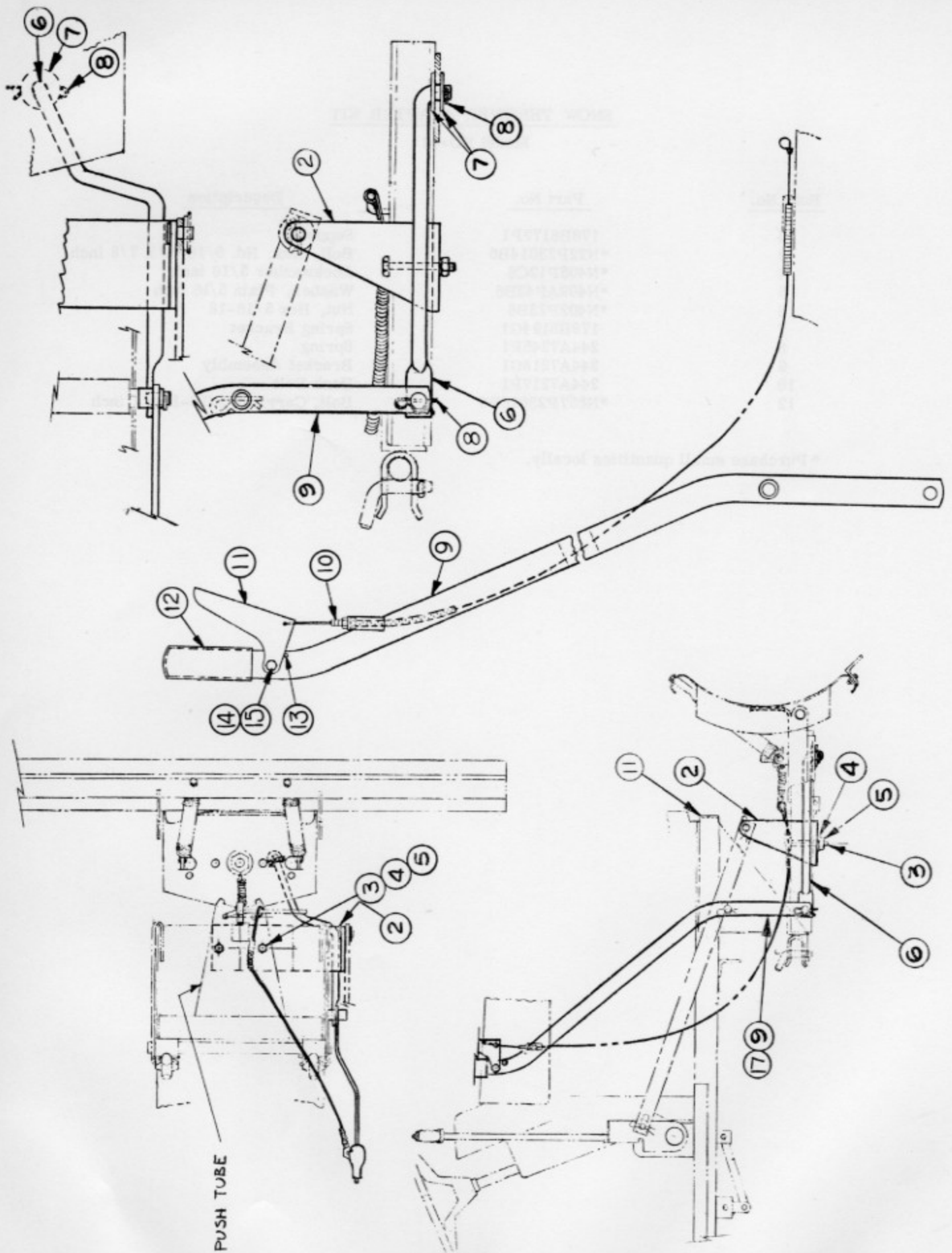

16-86

DOZER BLADE KIT

Model KB-48

<u>Ref. No.</u>	<u>Part No.</u>	<u>Description</u>
2	244A7456G1	Lift Bracket Assembly
3	*N22P25048B6	Bolt, Hex Hd. 3/8-16 x 3
4	*N405P13C6	Lockwasher, Spring 3/8 in.
5	*N210P25B6	Nut, Hex 3/8-16
6	244A7238G1	Rod Assembly
7	*N402AP47B6	Washer
8	243A4543P1	Hair Pin Cotter
9	178B8199G1	Handle
10	243A4904P2	Cable Assembly
11	178B8060P1	Hand Lever
12	243A4837P1	Hand Grip
13	*N509P1308B	Roll Pin .12 x .50 in.
14	*N22P21012B6	Bolt, Hex Hd. 1/4-20 x 3/4 in.
15	*N264P21B6	Locknut, Hex 1/4-20

\* Purchase small quantities locally.

DOWN BLADE KIT  
Model 22-42

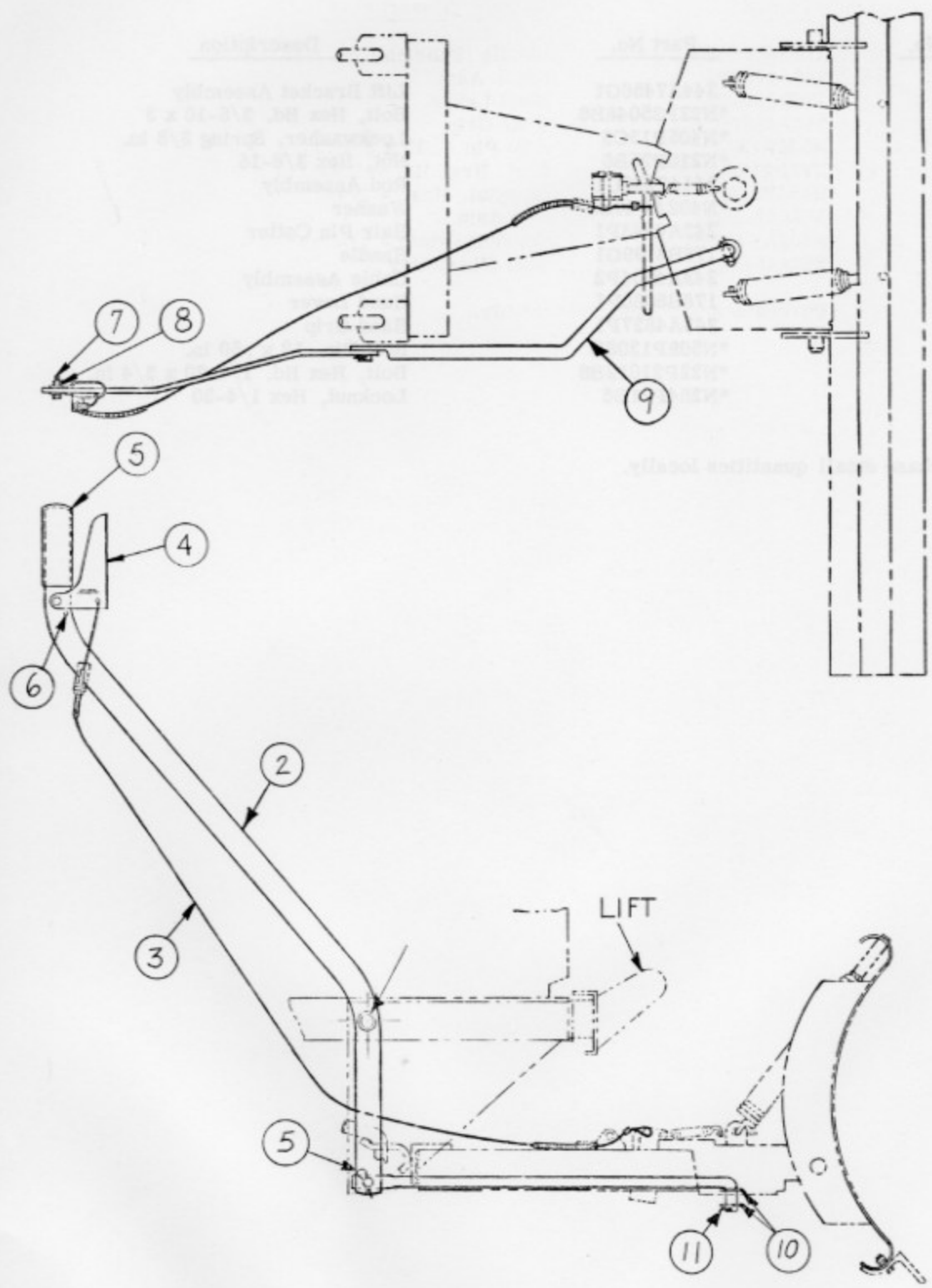

DOZER BLADE ADAPTER KIT (Angling Asm.)

KB84

<u>Ref. No.</u>	<u>Part No.</u>	<u>Description</u>
2	178B8058G2	Handle (Fabrication)
3	243A4904P3	Cable Asm.
4	178B8060P1	Hand Lever
5	243A4837P1	Hand Grip
6	N509P1308B	Roll Pin - .12 x 1/2 In.
7	*N22P21012B6	Bolt, Hex. Hd. - 1/4-20 x 3/4
8	*N264P21B6	Locknut, Hex. - 1/4-20
9	243A4903G1	Rod Asm.
10	*N402AP47B6	Washer, Plain - 5/8 In.
11	243A4543P1	Hair Pin Cotter

\*Purchase small quantities locally.

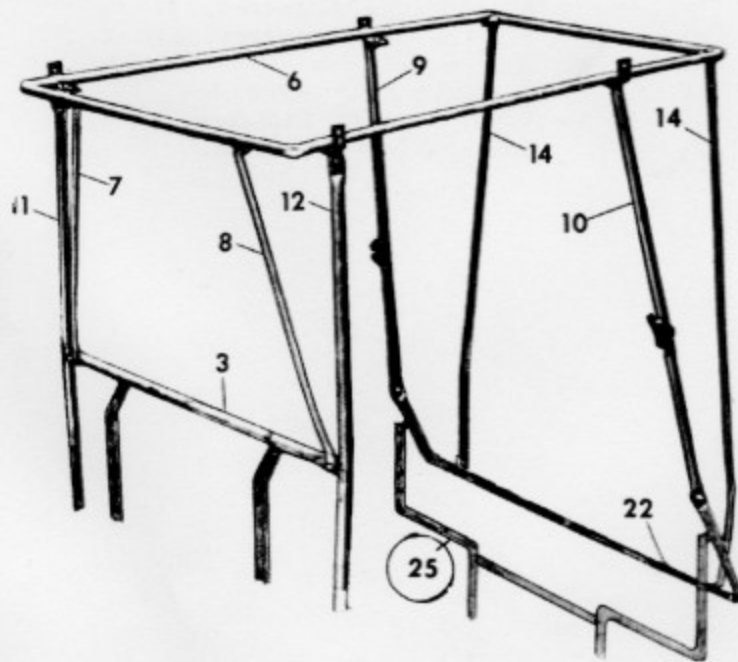
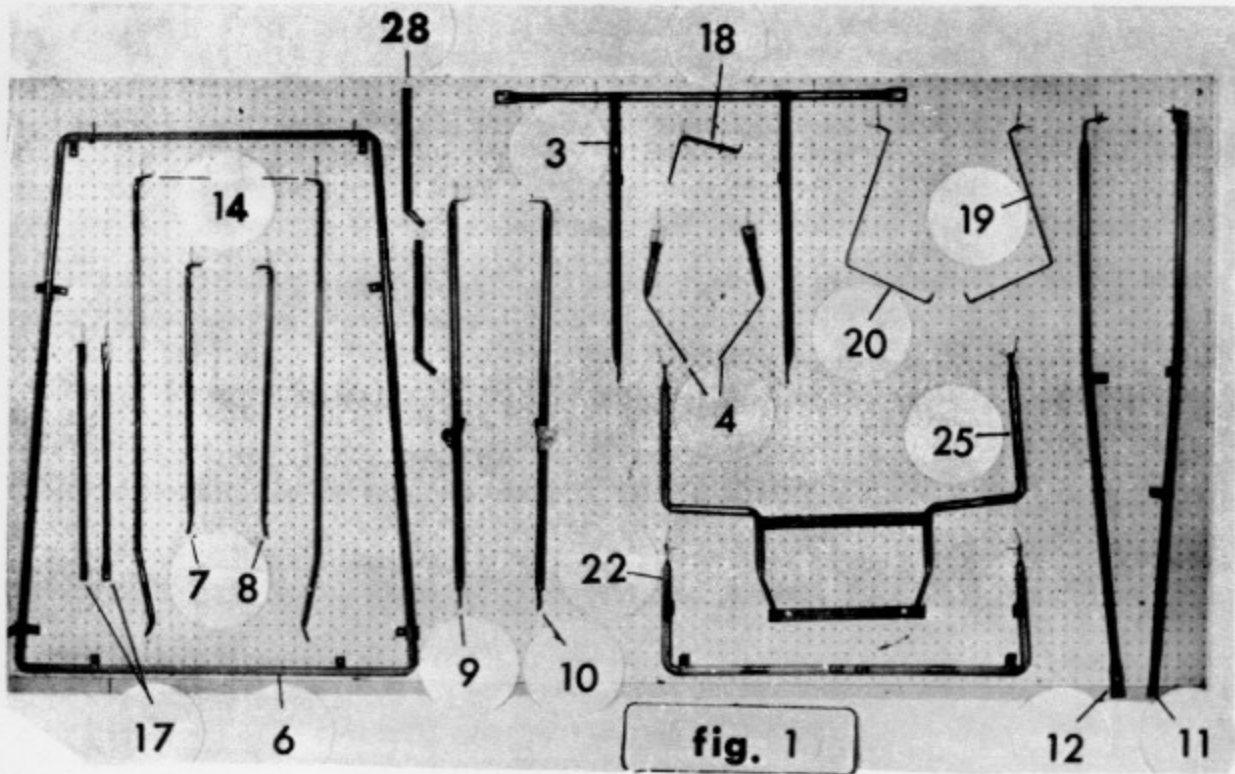

ENCLOSED CAB

Model AG54

<u>Ref. No.</u>	<u>Part No.</u>	<u>Description</u>
1	6335	Windshield (plastic)
3	6327	Front Panel Frame
4	6326	Foot, right and left hand
6	5648	Top Frame (large)
7	5630	Top Brace, right hand
8	5631	Top Brace, left hand
9	3071	Rear Corner Post, right hand
10	3072	Rear Corner Post, left hand
11	6325	Front Corner Post, right hand (special, bent)
12	2506	Front Corner Post, left hand
14	6333	Rear Curtain Boxing Post, right and left hand (spcl)
16	5551	Fiberglass Top (large, white)
17	6330	Front Brace, right and left hand
18	6340	Chute Control Support
19	6328	Foot Pocket Guard, right hand
20	6329	Foot Pocket Guard, left hand
21	6334	Front Panel, vinyl
22	6331	Rear Cross Bar
23	6336	Door, right hand
24	6337	Door, left hand
25	6332	Rear Attaching Bracket
27	6338	Rear Curtain, vinyl
28	6376	Rear Attaching Bracket Brace
	6339	Parts Bag (contents listed below)
<hr/>		
13	15	Door Hinge
	730	1/4"-20 Nut, lock
	729	5/16"-18 Nut, lock
	784	5/16"-18 x 3/4" Capscrew, hex
	788	1/4"-20 x 3/4" Capscrew, hex
	783	3/8"-16 x 3/4" Capscrew, hex
	790	3/8"-16 Nut, lock
	926	1/4"-20 x 1" Capscrew, hex
	2186	1/4"-20 x 1 1/4" Capscrew, hex
	3951	1/4" Flat Washer, S. A. E.

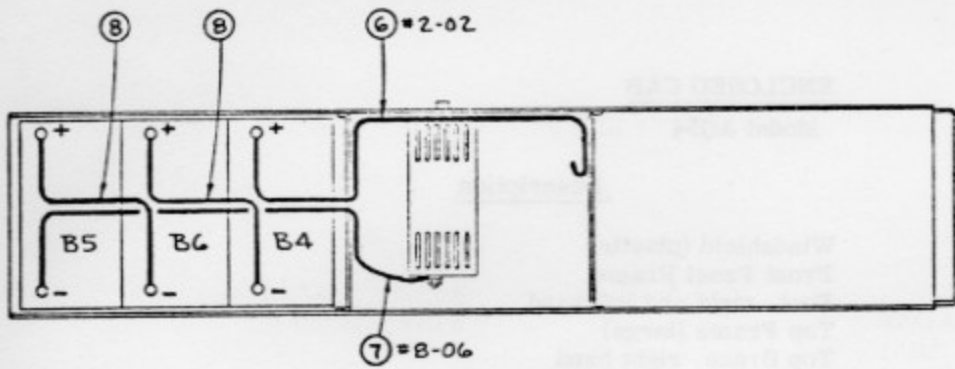

CONNECTION  
DIAGRAM

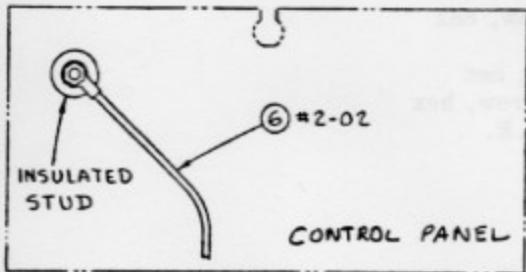
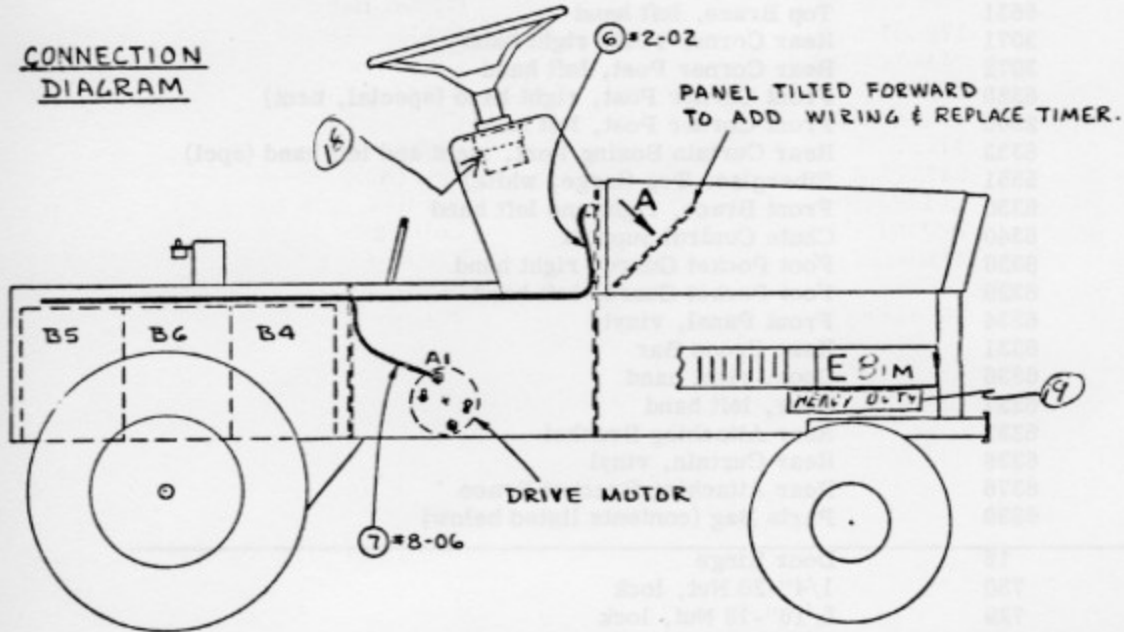

VIEW A SHOWING CONNECTION TO CONTROL  
PANEL - MODELS 26AEBBA AND LATER

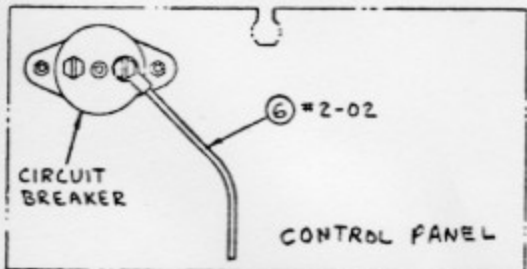

VIEW A SHOWING CONNECTION TO CONTROL  
PANEL - MODEL 26AESAA

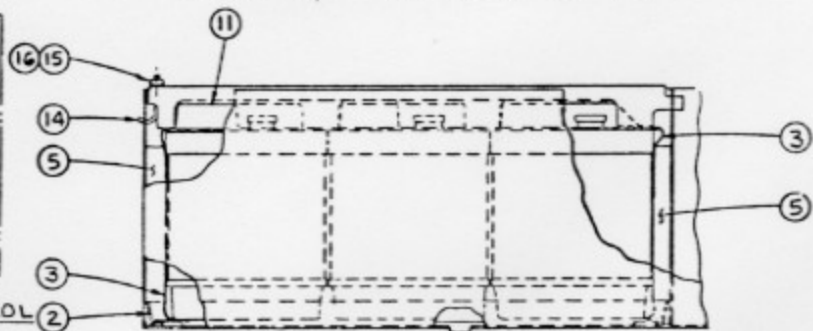
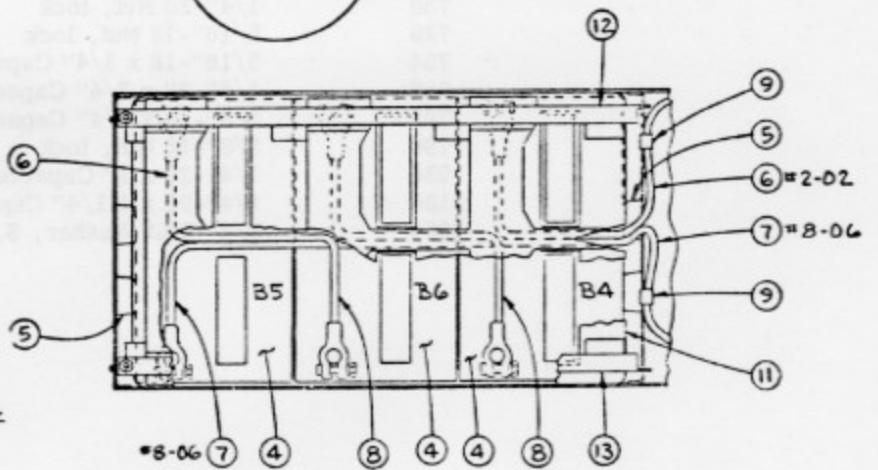

REAR BATTERY COMPARTMENT ASSEMBLY

E8M HEAVY DUTY KIT  
Model KT25

<u>Ref. No.</u>	<u>Part No.</u>	<u>Description</u>
2	155C8094 P1	Tray, Bat.
3	155C8122 P1	Liner
4	247A7495 G1	Battery (Dry Charge)
5	244A7313	Battery Protector
6	178B8165 G13	Cable, Batt. (#2-02)
7	178B8165 G14	Cable, Batt. (#8-06)
8	178B8165 G10	Cable, Batt.
9	244A7438 P1	Clip, Cable
11	247A7307 G1	Cover Asm.
12	178B8476 P1	Clamp Batt.
13	178B8476 P2	Clamp Batt.
14	247A7504 P1	Stud (Hold Down)
15	N210P21B6	Nut Hex, 1/4-20
16	N405P11C6	Lockwasher, 1/4
18	178B8238 G2	Timer Asm.
19	178B8479 P1	Decal (HD)
20	247A7496G1	Battery Cap

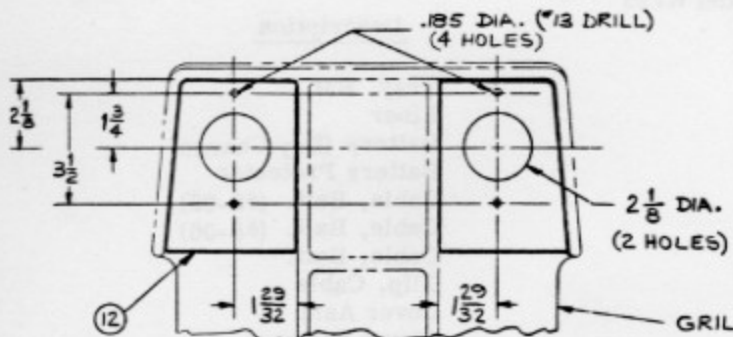

VIEW A SHOWING HOLES REQUIRED IN GRILL TO INSTALL HEAD LIGHTS. USE TEMPLATE PT.-12

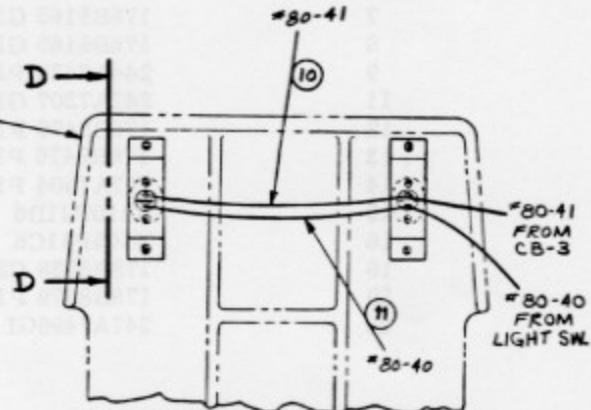

VIEW C SHOWING BACK VIEW OF HEAD LIGHTS.

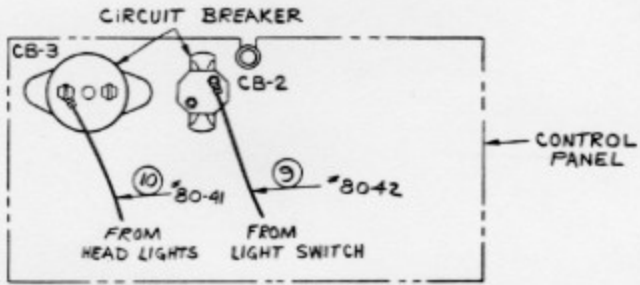

VIEW B SHOWING CONNECTIONS ON CONTROL PANEL FOR 26AEBA & 26AE10AA MODELS. SEE NOTE 6

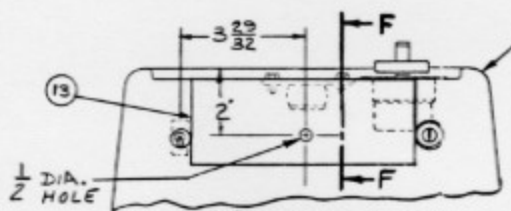

VIEW E SHOWING HOLE REQUIRED IN DASH COMPARTMENT TO INSTALL LIGHT SWITCH. USE TEMPLATE PT.-13

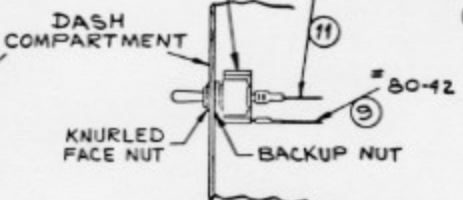

SECT. F-F SHOWING LIGHT SWITCH INSTALLED.

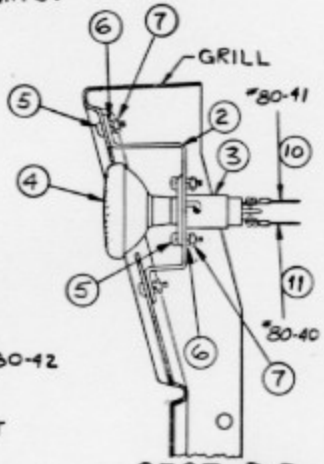

SECT. D-D SHOWING HEAD LIGHT INSTALLATION

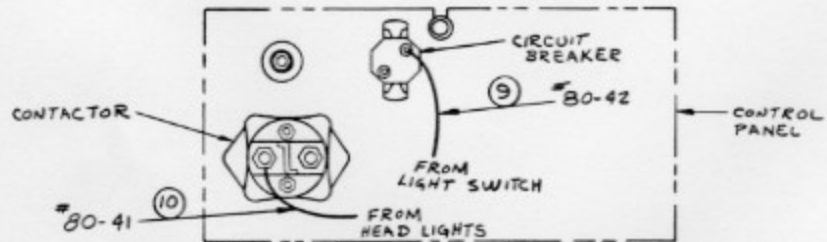

VIEW B SHOWING CONNECTIONS ON CONTROL PANEL FOR 26AE8BA & 26AE10BA MODELS. SEE NOTES 8 & 9

**HEAD LIGHT KIT**  
Model AP71

<u>Ref. No.</u>	<u>Part No.</u>	<u>Description</u>
2	178B8290 P1	Bracket
3	244A7446 P1	Socket Asm.
4	244A7443 P1	Lamp
5	N80P13006B6	Screw Pan Hd. #6-32 x 3/8
6	N405P7C6	Spring Lock Washer #6
7	N210P13B6	Nut, Hex. #6-32
8	243A4531 P3	Light Switch
9	178B8294 G1	Wire #80-42
10	244A7453 G2	Wire #80-41
11	244A7453 G1	Wire #80-40
12	178B8304 P1	Hole Template
13	178B8306 P1	Hole Template

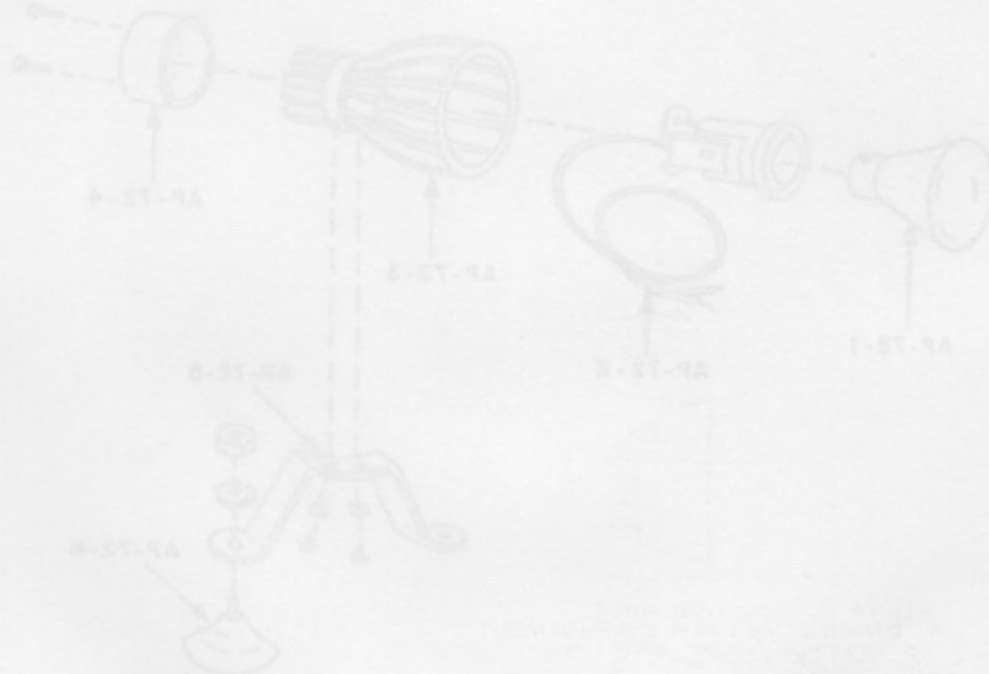

HEAD LIGHT WITH  
Model 72-1

Part No.	Description	Part No.	Description
1	Reflector	1	REFLECTOR
2	Socket Assy.	2	SOCKET ASSY.
3	Lamp	3	LAMP
4	Power Base 60-22 x 3/4	4	POWER BASE 60-22 X 3/4
5	Spring Lock Washer 48	5	SPRING LOCK WASHER 48
6	Hex. Nut 48-72	6	HEX. NUT 48-72
7	Light Switch	7	LIGHT SWITCH
8	Wire 480-42	8	WIRE 480-42
9	Wire 480-41	9	WIRE 480-41
10	Wire 480-40	10	WIRE 480-40
11	Hex. Washer 48	11	HEX. WASHER 48
12	Hex. Washer 48	12	HEX. WASHER 48
13	Hex. Washer 48	13	HEX. WASHER 48

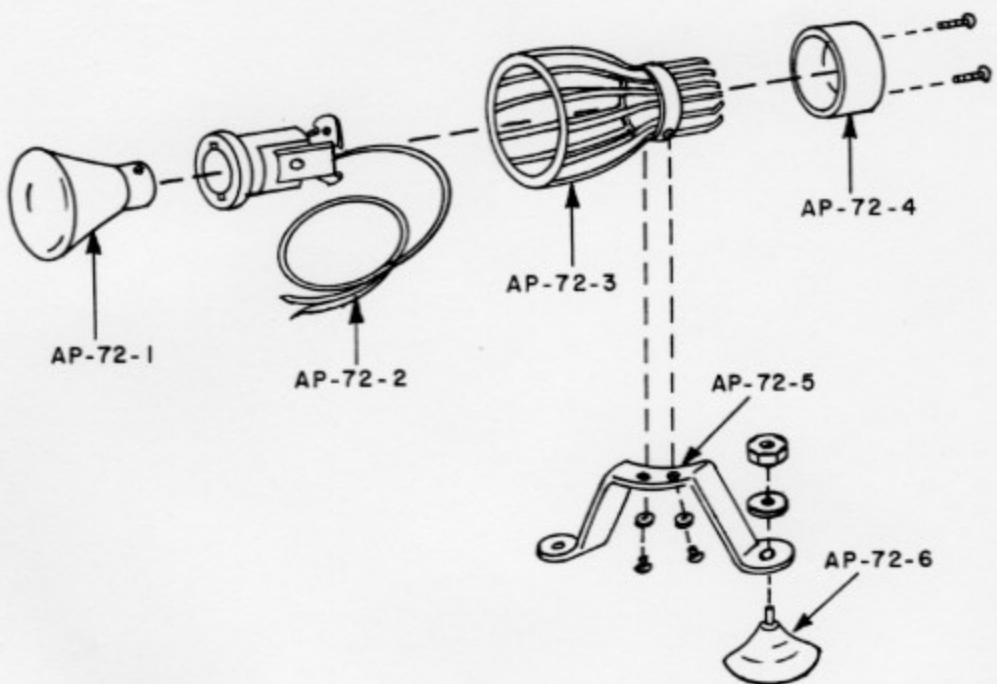

AUXILIARY LIGHT

AP72

When ordering parts, always specify model number, quantity, and description in detail.

Send orders direct to: Levolor Lorentzen Inc.  
720 Monroe Street  
Hoboken, New Jersey 07030

Telephone: 792-2600

<u>Ref. No.</u>	<u>Part No.</u>	<u>Description</u>
AP-72-1	244A7443P1	Bulb*
AP-72-2		Socket Assembly
AP-72-3		Cage Assembly
AP-72-4		Cap Group
AP-72-5		Mount Group
AP-72-6		Suction Cup Assembly

\* Order bulb from GE.

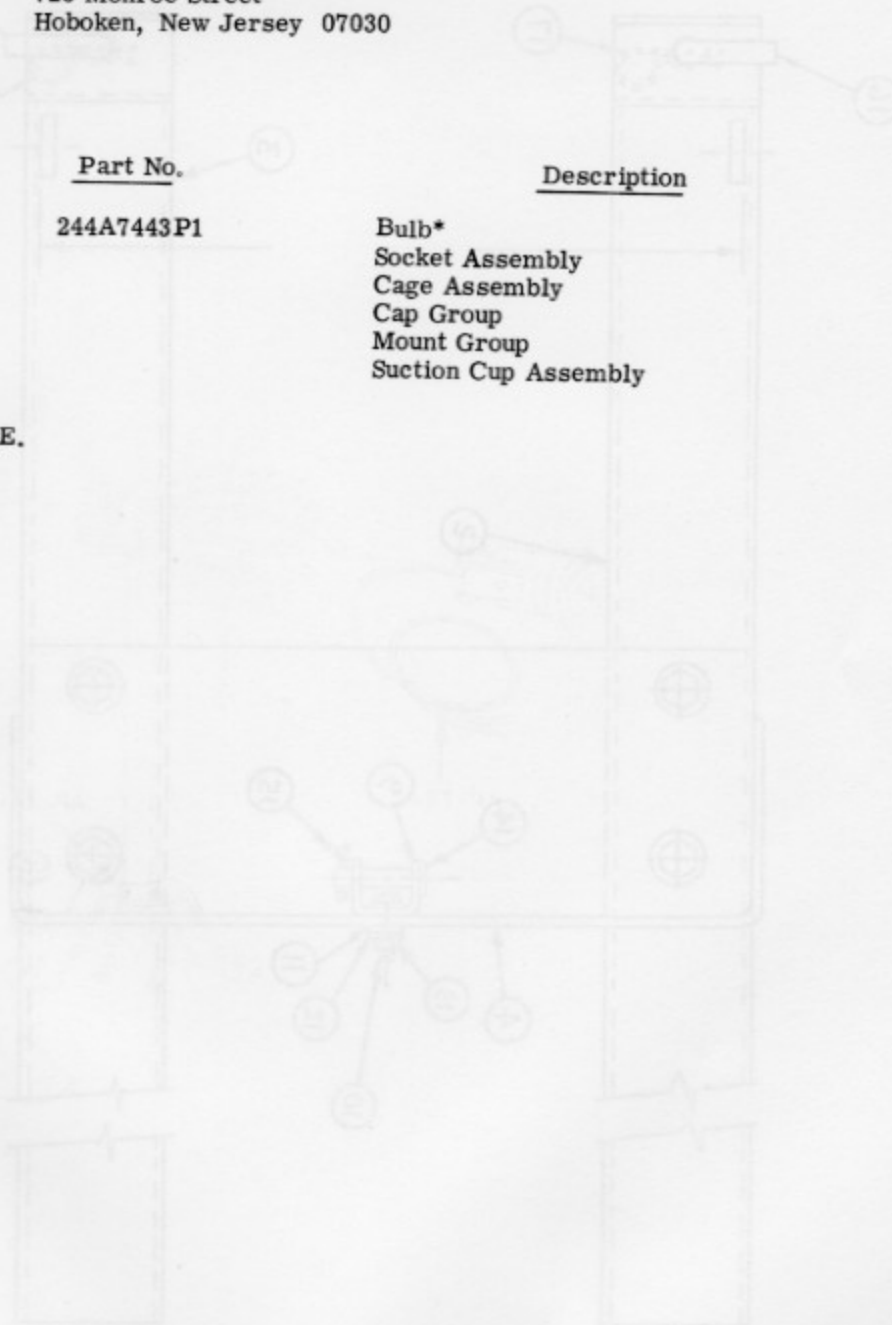

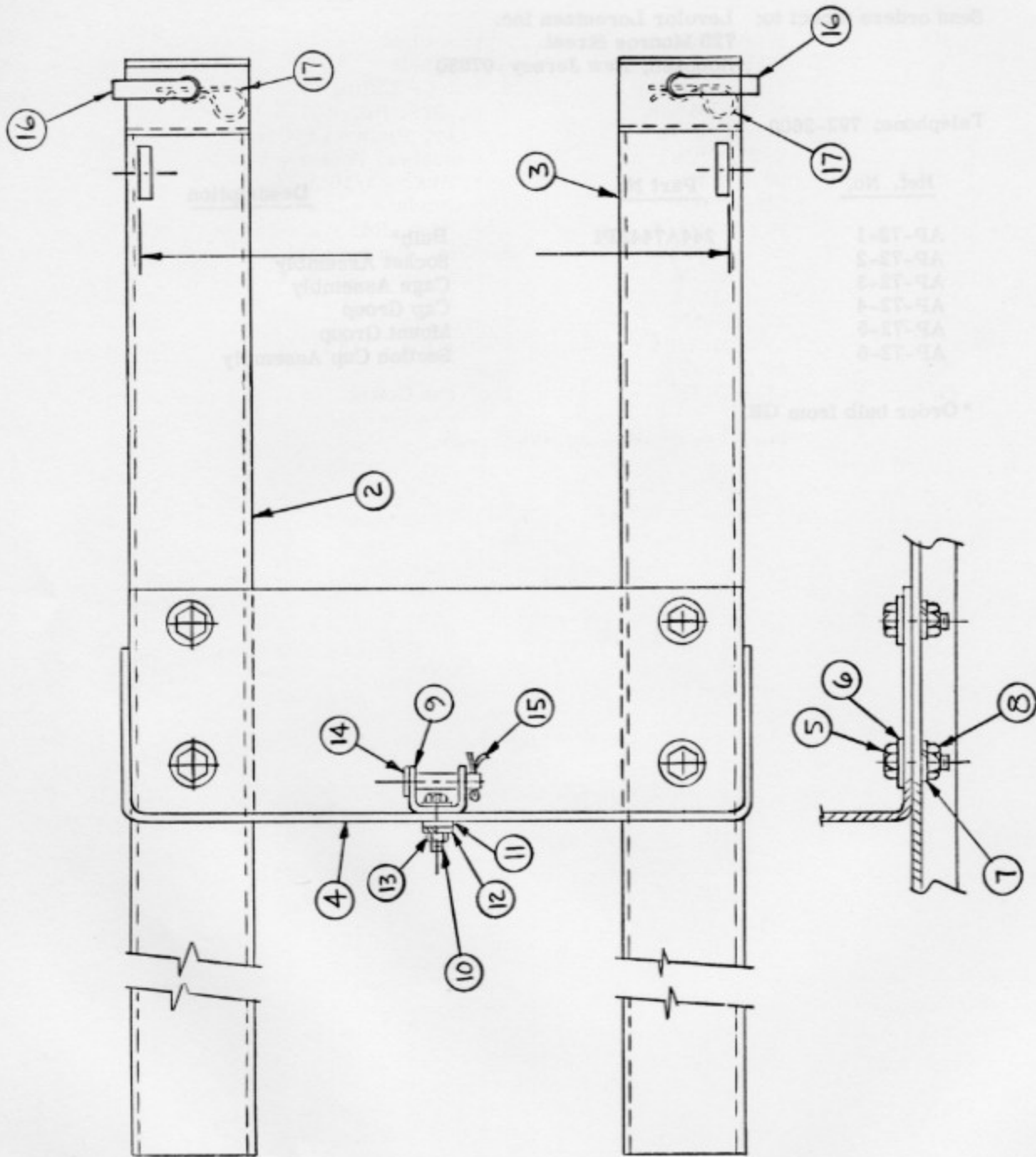

PALLET HANDLER

CP20

<u>Ref. No.</u>	<u>Part No.</u>	<u>Description</u>
2	178B8093G1	Arm - Right
3	178B8093G2	Arm - Left
4	155C8028P1	Bracket - Lifting
5	*N22P23016B6	Bolt, Hex. Hd. - 5/16-18 x 1 In.
6	*N402AP42B6	Washer, Plain - .344 In.
7	*N405P12C6	Lockwasher, Spring - 5/16 In.
8	*N210P23B6	Nut, Hex. - 5/16 In.
9	211A3231P1	Lift Clevis
10	*N22P21012B6	Bolt, Hex. Hd. - 1/4-20
11	*N402AP41B6	Washer, Plain - .281 In.
12	*N405P11C6	Lockwasher, Spring - 1/4 In.
13	*N210P21B6	Nut, Hex. - 1/4-20
14	211A3505P3	Clevis Pin
15	*N503P1212B6	Cotter Pin - 1/8 x 3/4 In.
16	247A7579P1	Pin
17	243A4543P1	Hair Pin Cotter

\*Purchase small quantities locally.

VALVE TIGHTENING

16-100

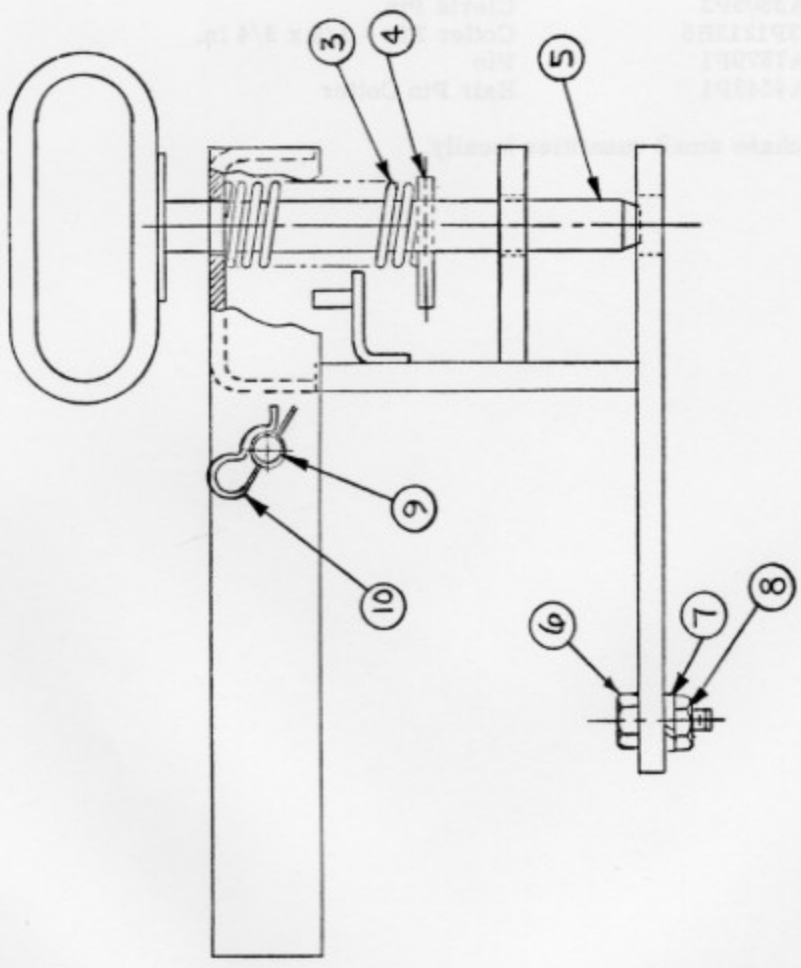

# SPRING PIN HITCH

CH11

<u>Ref. No.</u>	<u>Part No.</u>	<u>Description</u>
3	243A4995P1	Spring
4	N509P1928	Spring Dowel Pin - .188 x 1.75 in.
5	178B8087G1	Handle
6	*N22P29020B6	Bolt, Hex. Hd. - 1/2-13 x 1 1/4 in.
7	*N405P15C6	Lockwasher - 1/2 in.
8	*N258P29B6	Nut, Hex. - 1/2-13
9	211A3505P3	Clevis Pin
10	243A4543P1	Hair Pin Cotter

\*Purchase small quantities locally.

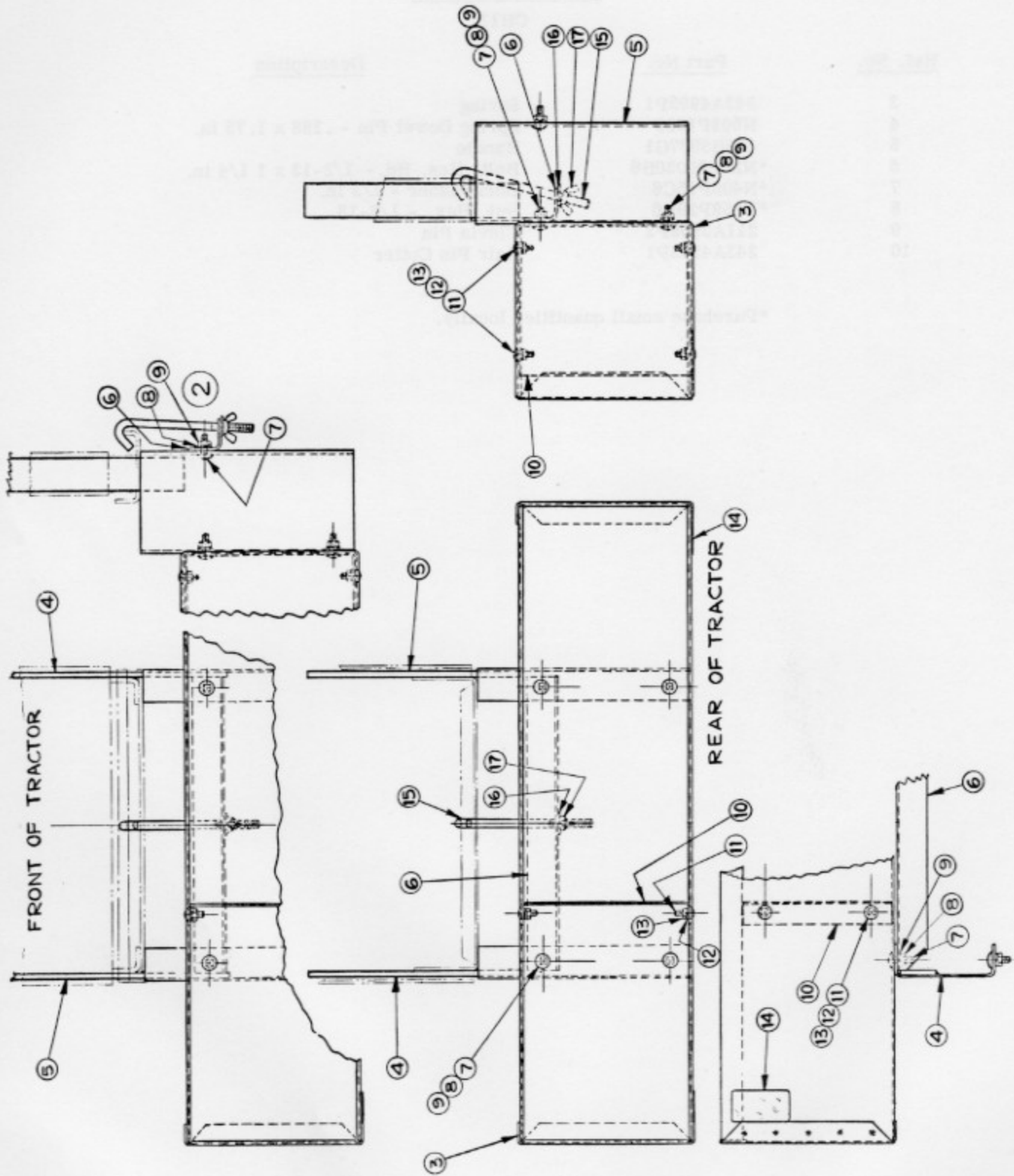

WEIGHT BOX

AP85

<u>Ref. No.</u>	<u>Part No.</u>	<u>Description</u>
3	155C8088P1	Weight Box
4	155C8089P1	Mounting Frame
5	155C8089P2	Mounting Frame
6	178B8192P1	Tie Down Angle
7	*N657P23016B6	Carriage Bolt - 5/16-18 x 1 In.
8	*N403P31C6	Lockwasher, Ext. Tooth - 5/16 In.
9	*N258P23B6	Nut, Hex. - 5/16-18
10	178B8193P1	Divider
11	*N657P21012B6	Carriage Bolt - 1/4-20 x 3/4
12	*N403P25C6	Lockwasher, Ext. Tooth - 1/4 In.
13	*N258P21B6	Nut, Hex. - 1/4-20
14	243A4870P1	Tail Reflector
15	244A7219P1	Hook - Threaded
16	*N402AP44B6	Washer - 7/16 In.
17	*N236P25B6	Nut, Wing - 3/8-16

\*Purchase small quantities locally.

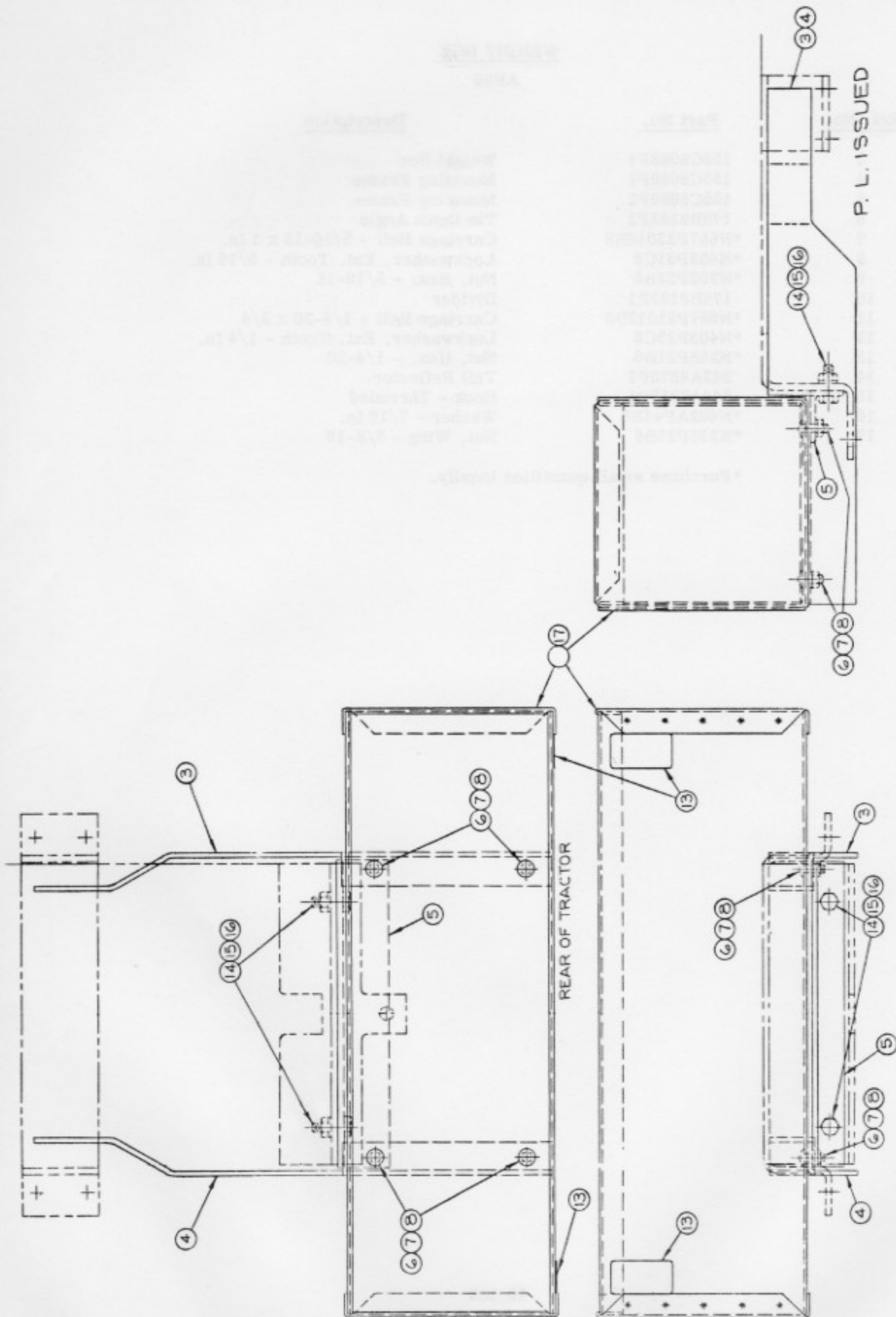

WEIGHT BOX

AP86

<u>Ref. No.</u>	<u>Part No.</u>	<u>Description</u>
3	178B8315P1	Mounting Bracket
4	178B8315P2	Mounting Bracket
5	244A7468P1	Angle
6	*N657P23016B6	Carriage Bolt - 5/16-18 x 1 In.
7	*N403P31C6	Lockwasher - 5/16 In.
8	*N258P23B6	Nut, Hex. - 5/16-18
13	243A4870P1	Tail Reflector
14	*N657P21012B6	Bolt, Hex. - 3/8-16 x 1 1/4 In.
15	*N405P73C6	Lockwasher - 3/8 In.
16	*N258P25B6	Nut, Hex. - 3/8-16
17	155C8179G2	Weight Box

\*Purchase small quantities locally.

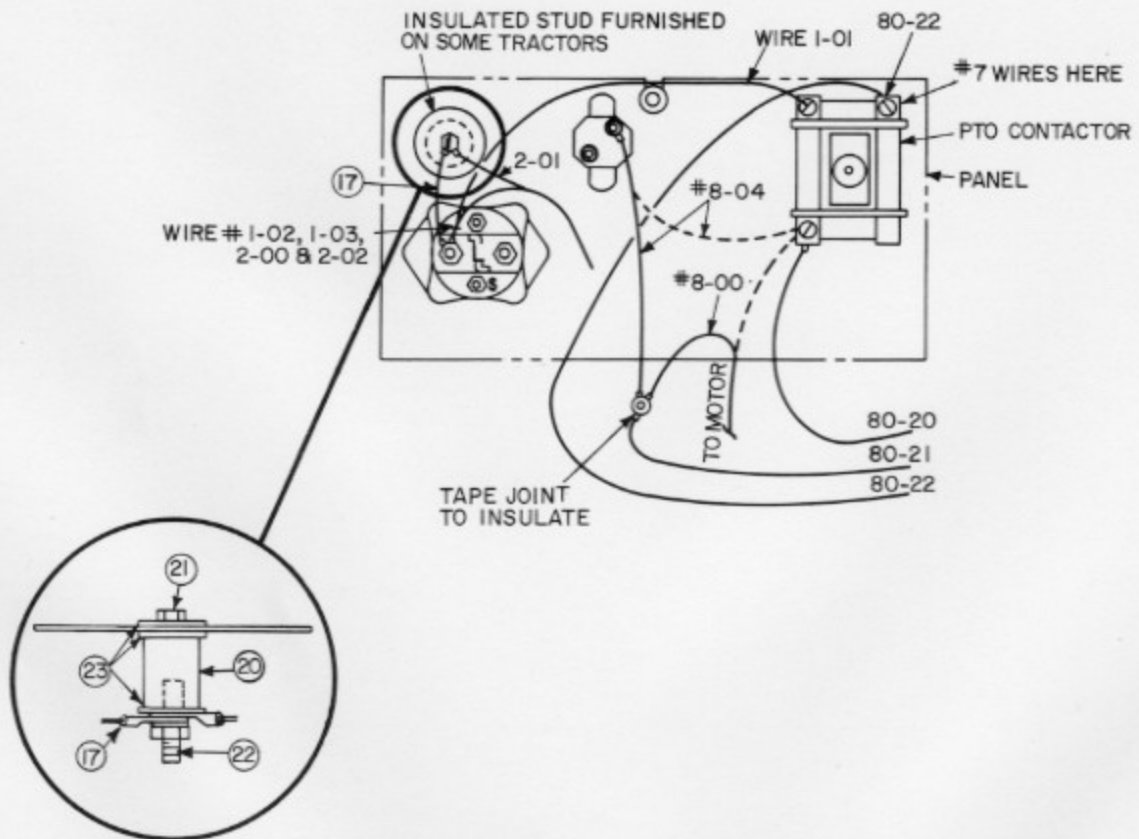
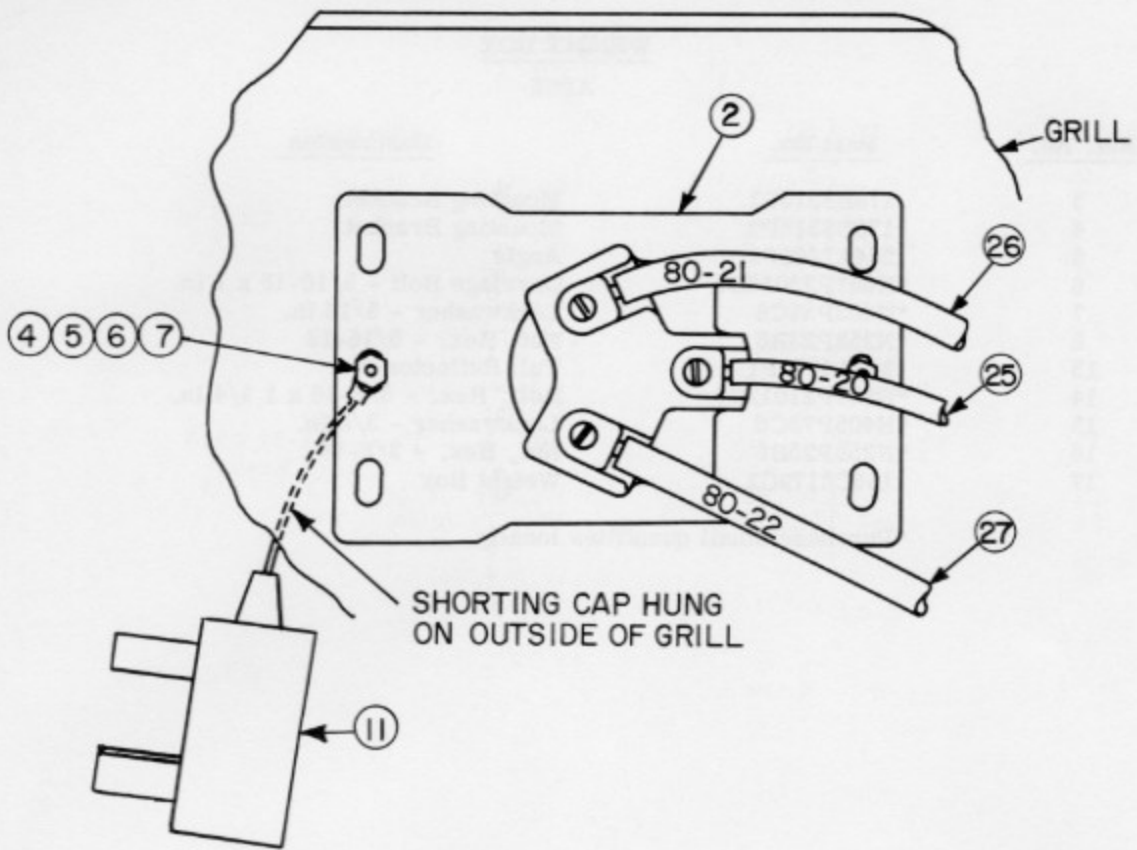

PTO KIT

KD10

<u>Ref. No.</u>	<u>Part No.</u>	<u>Description</u>
2	243A4572P1	Outlet
4	*N80P15008B6	Screw, Phillips - 8-32 x 1/2 In.
5	*N402AP38B6	Washer #8
6	*N405P8C6	Lockwasher #8
7	*N210P15B6	Nut, Hex. - 8-32
11	244A7440G1	Cap - Shorting
17	211A3448G2	Fuse Link
19	*N402AP41B6	Washer - 1/4 In.
20	211A3165P1	Insulator
21	N22P21010B6	Bolt, Hex. Hd. - 1/4-20 x 5/8
22	*N90P21018	Stud - 1/4-20 x 1 1/8 Brass
23	*N402AP71B6	Washer - 1/4 In.
24	244A7449P1	Hole Template
25	178B8298G5	Wire #80-20
26	178B8298G2	Wire #80-21
27	178B8298G1	Wire #80-22

\* Purchase small quantities locally.

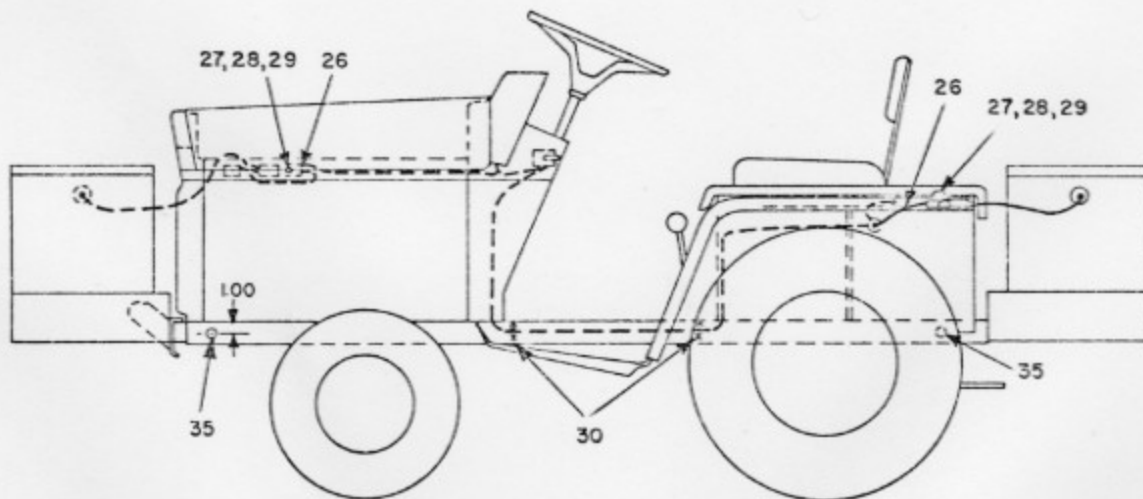
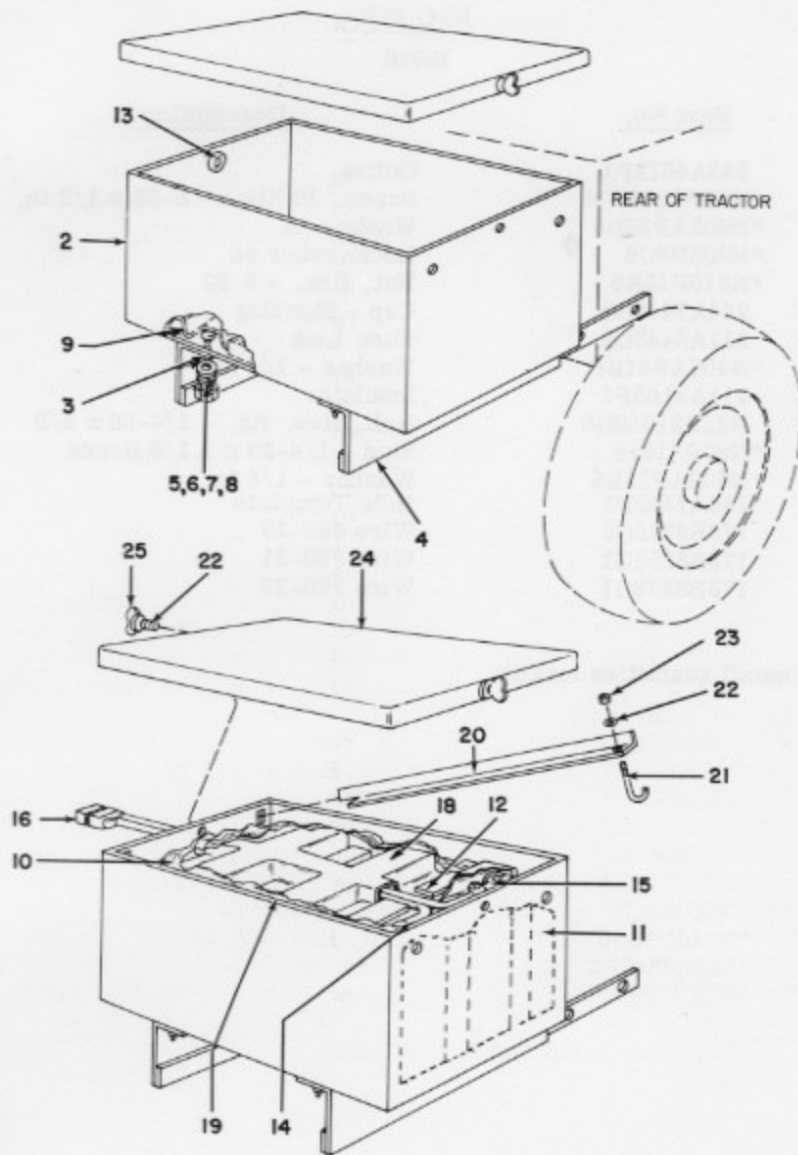

POWER PACK BOOSTER

AP84

<u>Ref. No.</u>	<u>Part No.</u>	<u>Description</u>
2	158C9043G1	Box Shell Asm.
3	178B8455G1	Support Bracket Asm.
4	178B8455G2	Support Bracket Asm.
5	*N657P25016B6	Carriage Bolt - 3/8-16 x 1 In.
6	*N402AP43B6	Washer - 3/8 In.
7	*N405P13C6	Lockwasher - 3/8 In.
8	*N258P25B6	Nut, Hex. - 3/8-16
9	155C8094P1	Battery Tray
10	155C8122P1	Liner
11	244A7313P1	Battery Protector
12	247A7495G1	Battery (Dry Charged)
13	211A3589P3	Grommet
14	178B8165G10	Battery Cable
15	243A4521P1	Post Clamp
16	178B8495G1	Connector Lead
17	AP31	Battery Terminal Protector (Grease)
18	247A7307G1	Battery Cover Asm.
19	178B8476P1	Battery Clamp
20	178B8476P2	Battery Clamp
21	247A7504P1	Stud
22	*N405P11C6	Lockwasher - 1/4 In.
23	*N210P21B6	Nut, Hex. - 1/4-20
24	178B8451P1	Cover
25	243A4571P1	Screw
26	178B8495G2	Connector Lead
27	*N68P15016B6	Screw - 8-32 x 1 In.
28	*N405P8C6	Lockwasher #8
29	*N210P15B6	Nut, Hex. - 8-32
30	*243A4540P2	Wire Tie
35	*N22P23008B6	Screw, Hex. - 5/16-18 x 1/2 In.

\*Purchase small quantities locally.

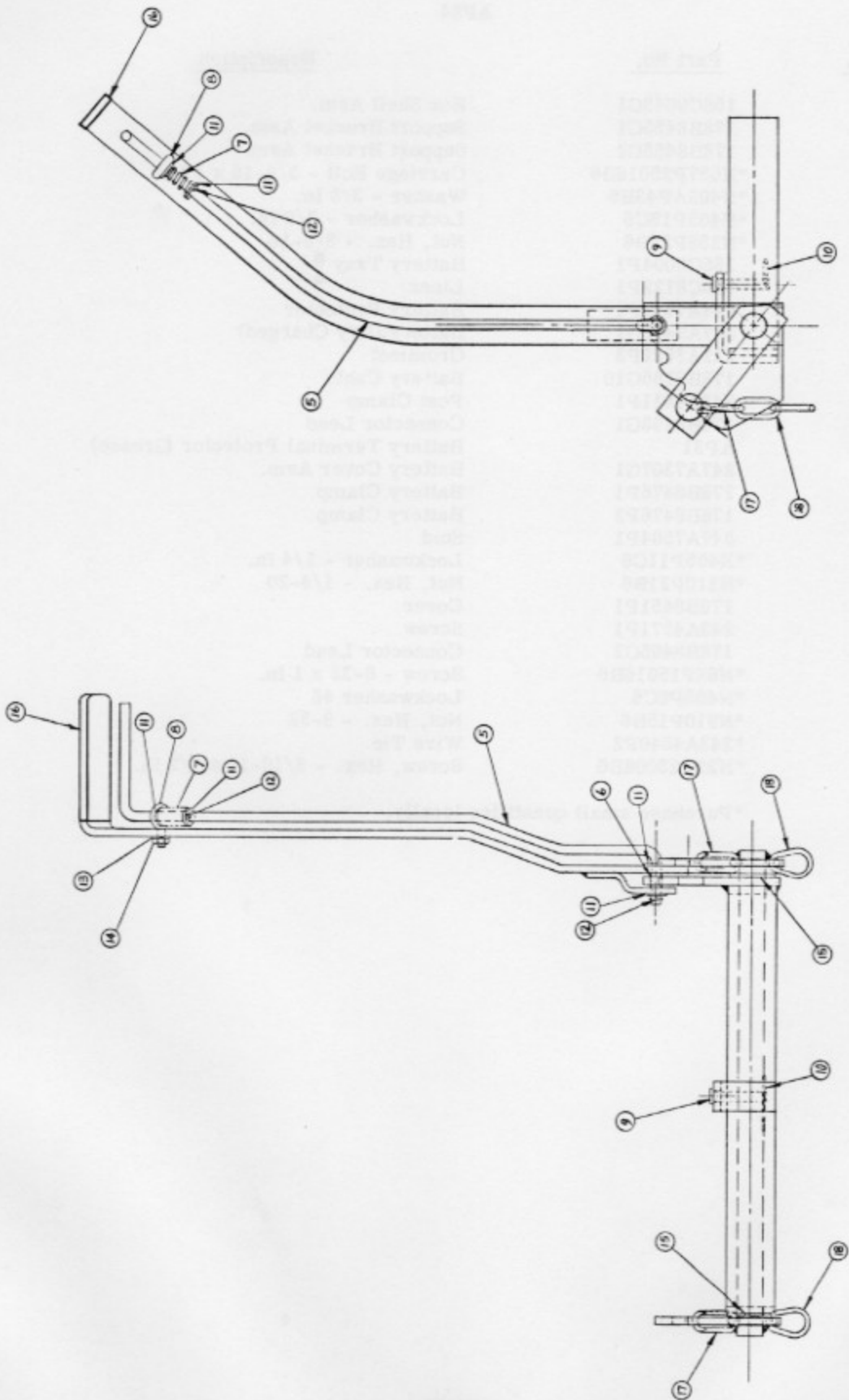

MANUAL LIFT

AP58

<u>Ref. No.</u>	<u>Part No.</u>	<u>Description</u>
5	178B8028P1	Rod
6	243A4844P1	Roller
7	211A3577P9	Spring
8	243A4868P1	Eye Bolt
9	211A3505P3	Clevis Pin
10	243A4543P1	Hair Pin Cotter
11	*N402AP12B6	Washer - 5/16 In.
12	*N503P616B6	Cotter Pin
13	*N405P9C6	Lockwasher #10
14	*N210P16B6	Nut, Hex. - 10-32
15	*N402AP19B6	Washer - 7/8 In.
16	243A4837P1	Hand Grip
17	243A4845P1	Lap Link
18	243A4842P1	Connecting Chain

\*Purchase small quantities locally.

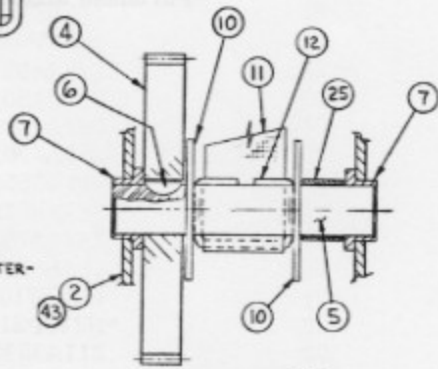
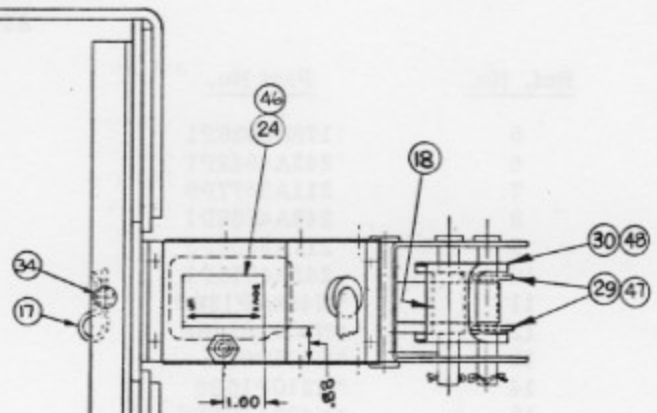
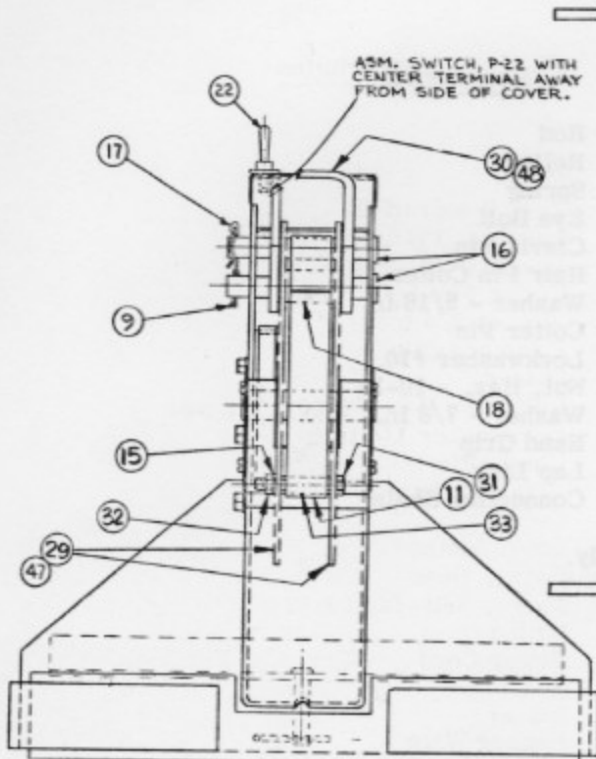

SECTION B-B  
SCALE 1:1

NOTE:  
TAPE, P-11, MUST BE ASM. OVER TOP SIDE OF BOTH PINS, P-16.  
GEAR, P-4, MUST ROTATE COUNTER-CLOCKWISE (CCW) TO LIFT.

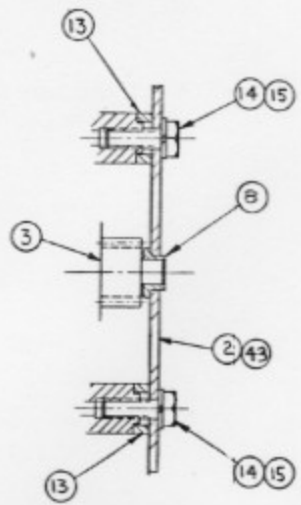
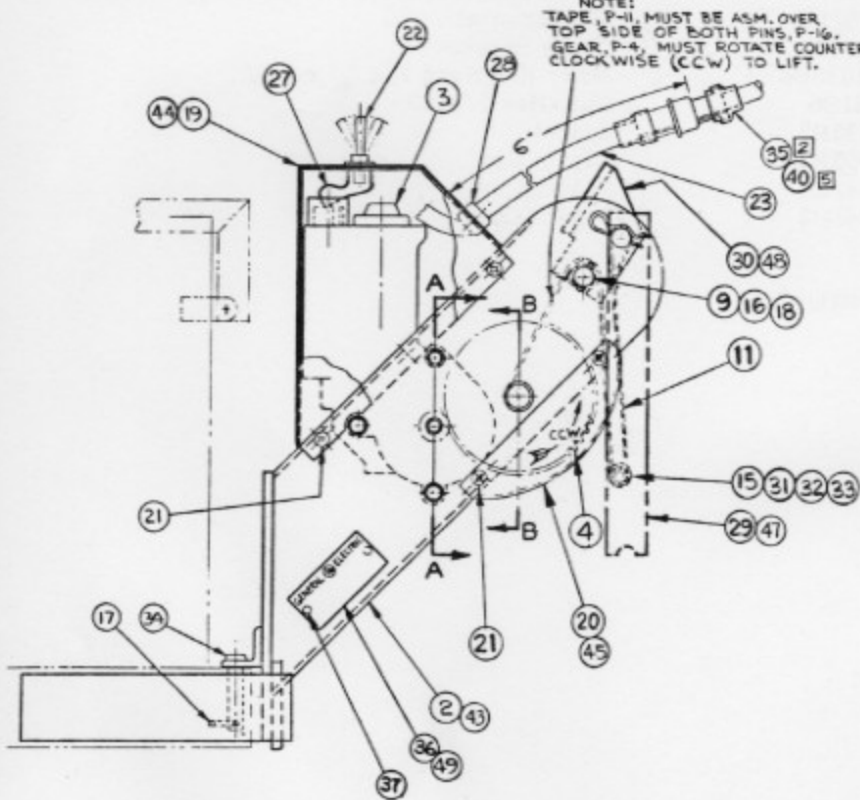

SECTION A-A  
SCALE 1:1

ELECTRIC LIFT (REAR)

Model AP59

<u>Ref. No.</u>	<u>Part No.</u>	<u>Description</u>
3	211A3202P1	Motor
4	211A3190P1	Gear
5	211A3189P1	Shaft
6	*N3400P404	Key, Woodruff #3
7	211A3540P3	Bearing, Flanged
8	211A3540P1	Bearing, Flanged
9	*N503P1016B6	Cotter Pin 1/10 x 1 inch
10	*N402AP47B6	Washer 3/4 inch
11 & 12	163B9802G1	Strap and Clip
13	211A3541P1	Spacer
14	N22P21014P6	Bolt, Hex Hd. 1/4-20 x 7/8 inch
15	N405P11C6	Lockwasher 1/4 inch
16	211A3505P5	Clevis Pin
17	243A4543P1	Hair Pin Cotter
18	211A3543P2	Sleeve
19	163B9930G1	Cover Motor
20	163B9959G1	Cover, Gear
21	N600P16005C6	Screw, Self-Tap 10-32 x 5/16 inch
22	243A4531P2	Switch
23	243A4601G1	Power Cord
24	243A4586P1	Decal
25	243A4702P1	Spacer
27	211A3556G4	Jumper Wire
28	243A4529P3	Strain Relief Bushing
29	243A4701P1	Stop Bracket
30	163B9964P1	Chain Bracket
31	*N22P21028B6	Bolt, Hex Head 1/4-20 x 1 3/4
32	*N210P21B6	Nut, Hex 1/4-20
33	211A3535P2	Spacer
34	211A3505P3	Clevis Pin
35	163B9942G1	Power Cord
40	163B9942G2	Power Cord

\* Purchase small quantities locally.

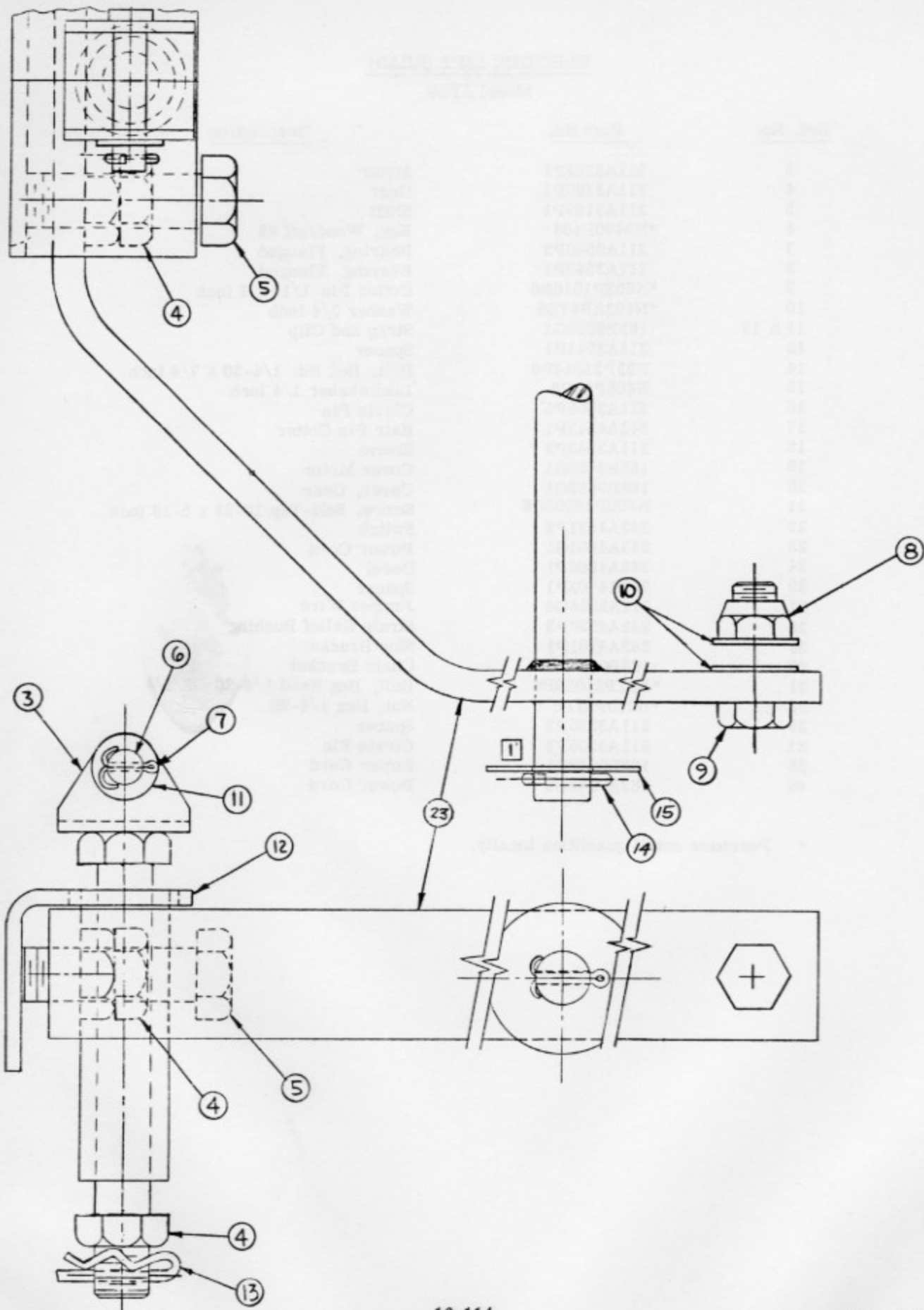

SLEEVE HITCH

AP50

<u>Ref. No.</u>	<u>Part No.</u>	<u>Description</u>
3	211A3587G1	Hitch Pin Asm.
4	*N245P33B6	Nut, Hex. - 5/8-11
5	244A7979P1	Bolt, Hex. Hd. - 5/8-11 x 2 1/2 In.
6	211A3505P3	Clevis Pin
7	*N503P1212B6	Cotter Pin - 1/8 x 3/4 In.
8	*N264P29B6	Locknut - 1/2-13
9	*N22P29022B6	Bolt, Hex. Hd. - 1/2-13 x 1 3/8 In.
10	*N402AP15B6	Washer - 1/2 In.
11	*N402AP13B6	Washer - 1/2 In.
12	211A3586P1	Stabilizer Plate
13	243A4543P1	Hair Pin Cotter
14	*N503P1216B6	Cotter Pin - 1/8 x 1 In.
15	*N402AP47B6	Washer - 3/4 In.
23	163B9925G4	Yoke Asm.

\*Purchase small quantities locally.

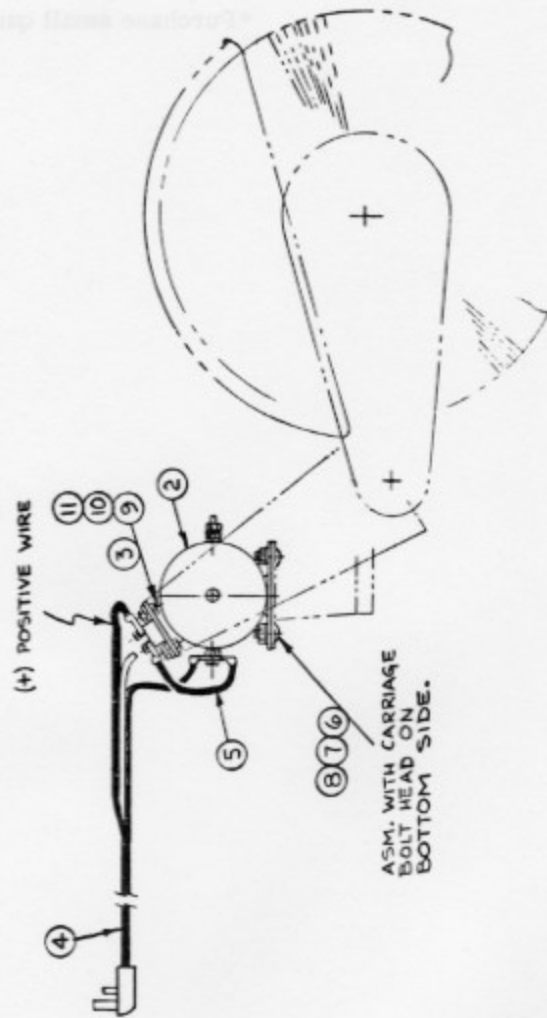
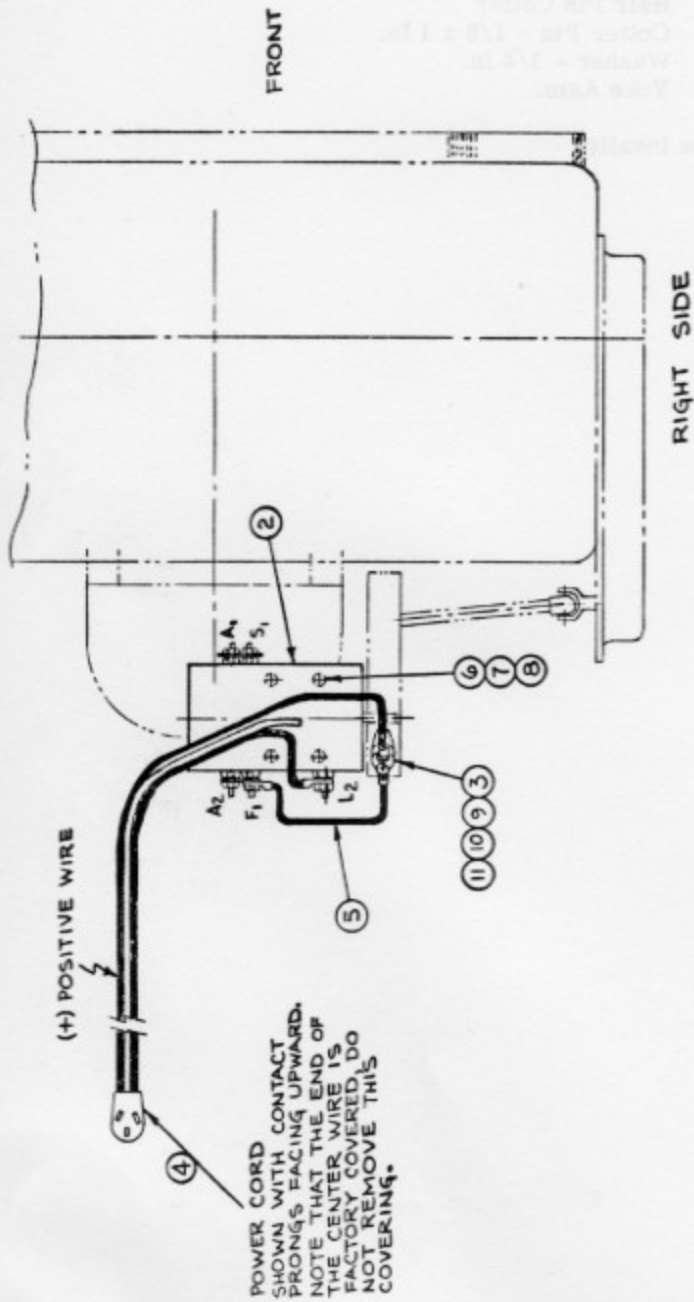

THIS KIT FURNISHES THE MOTOR AND ITS WIRING ACCESSORIES NECESSARY TO CONVERT ONE (1) SWEEPSTER BROOM MODEL C48 MFD. BY JENKINS EQUIP. CO. INC. DEXTER, MICH.

①

SWEEPSTER-ELECTRIC MOTOR DRIVE KIT

KM10

<u>Ref. No.</u>	<u>Part No.</u>	<u>Description</u>
2	178B8170P1	Motor
3	211A3244P2	Circuit Breaker
4	243A4579G1	Power Cord
6	*N657P23016B6	Carriage Bolt - 5/16-18 x 1 In.
7	*N405P12C6	Lockwasher - 5/16 In.
8	*N210P23B6	Nut, Hex. - 5/16-18
9	*N68P16014B6	Screw, Hex. Hd. - 10-32 x 7/8 In.
10	*N405P9C6	Lockwasher #10
11	*N210P16B6	Nut, Hex. - 10-32

Note 1: Not stocked, order locally.

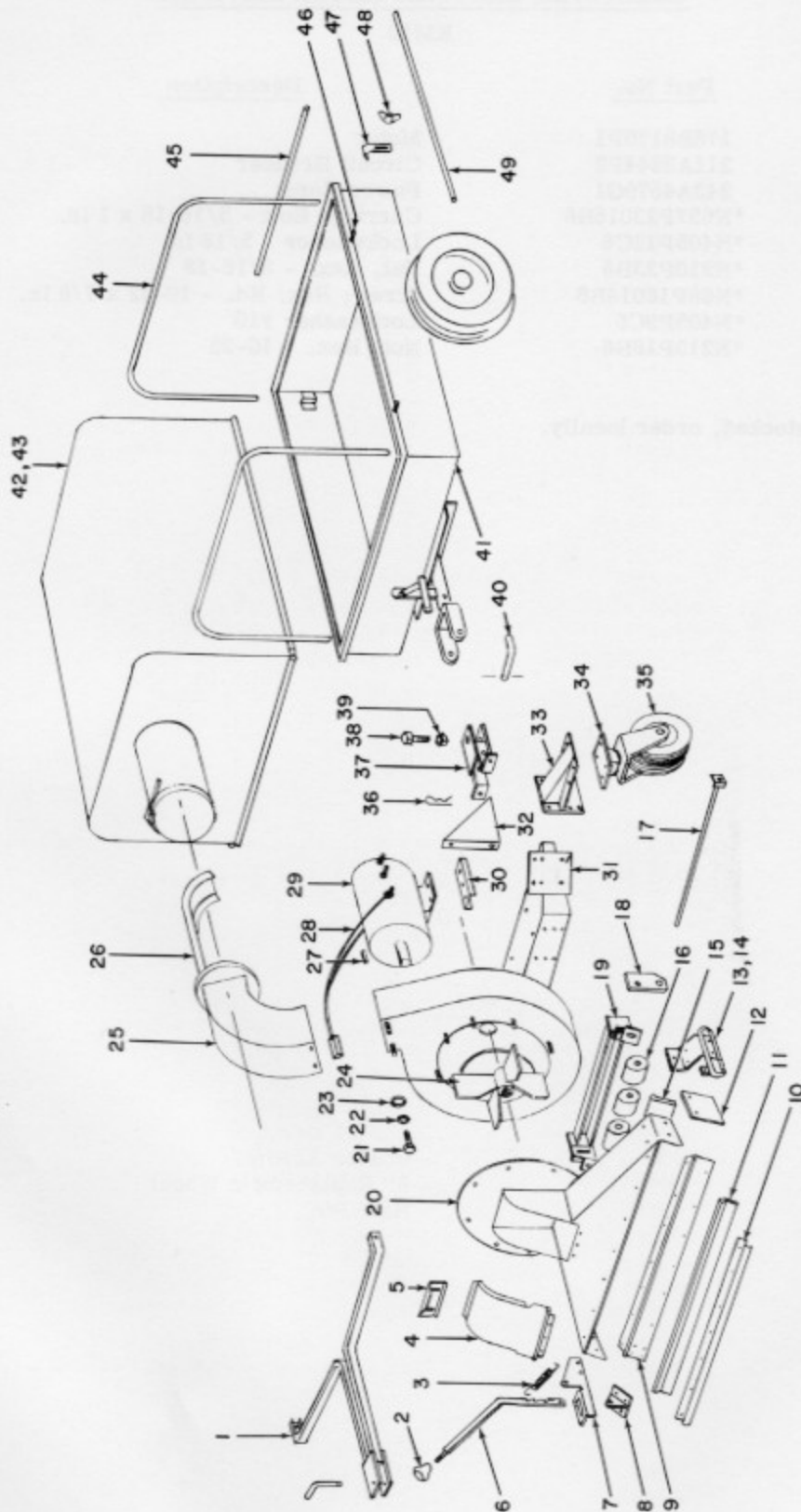

VACUUM

CV70

When ordering parts, always specify model number, quantity, and description.

Sent orders direct to: Sensation Products  
Russell Road  
East Granby, Connecticut 06026

Or call: Area Code (203) 658-2226

<u>Ref. No.</u>	<u>Part No.</u>	<u>Description</u>
1	40425-0	Tow Bar Assem.
2	60244	Knob, Lift Lever
3	60047	Spring
4	40453-0	Cover Assem., Intake
5	60018-0	Latch
6	60420-0	Lift Lever
7	60424-0	Bracket Spring and Lever
8	40423-0	Bracket - Door
9	40111-0	Door Assem.
10	60352-0	Clamping Strip Front and Rear
11	60351	Skirt - Door
12	60419	Skirt - Side
13	40452-0	Skid Plate L. H.
14	40451-0	Skid Plate R. H.
15	60418	Skirt - Rear
16	60428	Rollers - 3" x 5"
17	40450-0	Shaft Assem.
18	60412-0	Plate - Roller
19	40417-0	Carrier Bar Assem.
20	40397-0	Intake Assem.
21	60077	Bolt - 5/16-18-24 x 1 3/4
22	60076	Washer - 5/16 Lock
23	60075	Washer - 5/16 Flat
24	60079	Impeller - 12" Dia.
25	40138	Chute Assem.
26	40455-0	Deflector
27	60074	Key - 3/16 Sq. x 1 1/2
28	40404	Wire Harness Assem.
29	60391	Motor - GE
30	60095-0	Riser Channel
31	40389-0	Motor Base
32	60392-0	Brace Hsg/Base
33	60433-0	Caster Bracket
34	40434	Caster Assem.
35	60487	8" Replacement Wheel
36	60460	Hair Pin
37	40489-0	Yoke - Draw Bar
38	60490	Bolt - 1/2-13 x 2
39	60491	Hex. Nut - 1/2-13
40	60459	Clevis Pin
41	20443	Trailer Assem.
42	60439	Cover (Canton Fabric)
43	60492	Cover (Bead Bag Mat)
44	60440	Bow - Venting Cover
45	60442	Tubing - Front and Rear
46	40482	Stud Assem.
47	60481-0	Latch - Cover
48	60193	Wing Nut - 5/16-18
49	60441	Tubing - Side

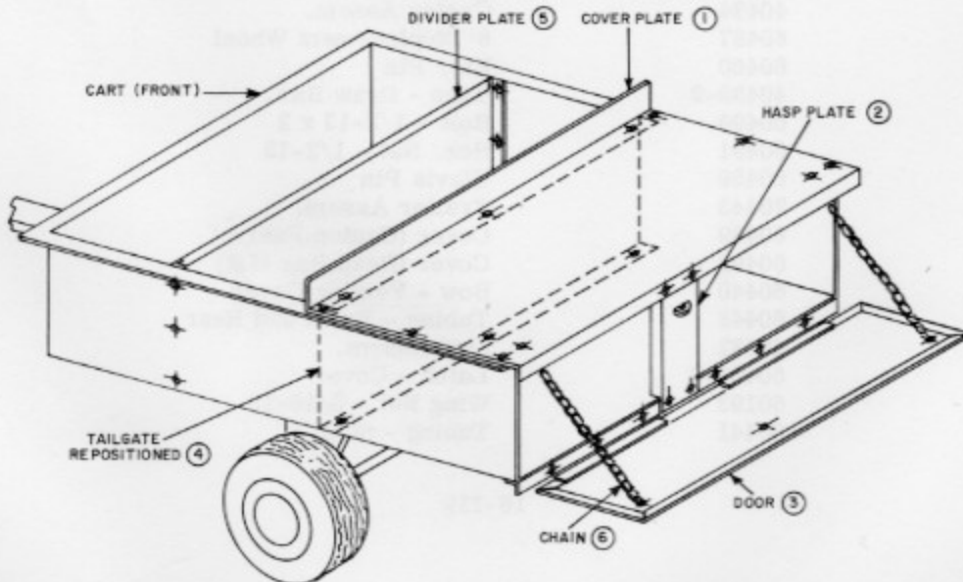

MAINTENANCE CART

CF20

<u>Ref. No.</u>	<u>Part No.</u>	<u>Description</u>
1	CF-20-1	Cover Plate
2	CF-20-2	Hasp Plate
3	CF-20-3	Door
4	CF-20-4	Tail Gate
5	CF-20-5	Divider Plate
6	CF-20-6	Stop Chain (2 Required)

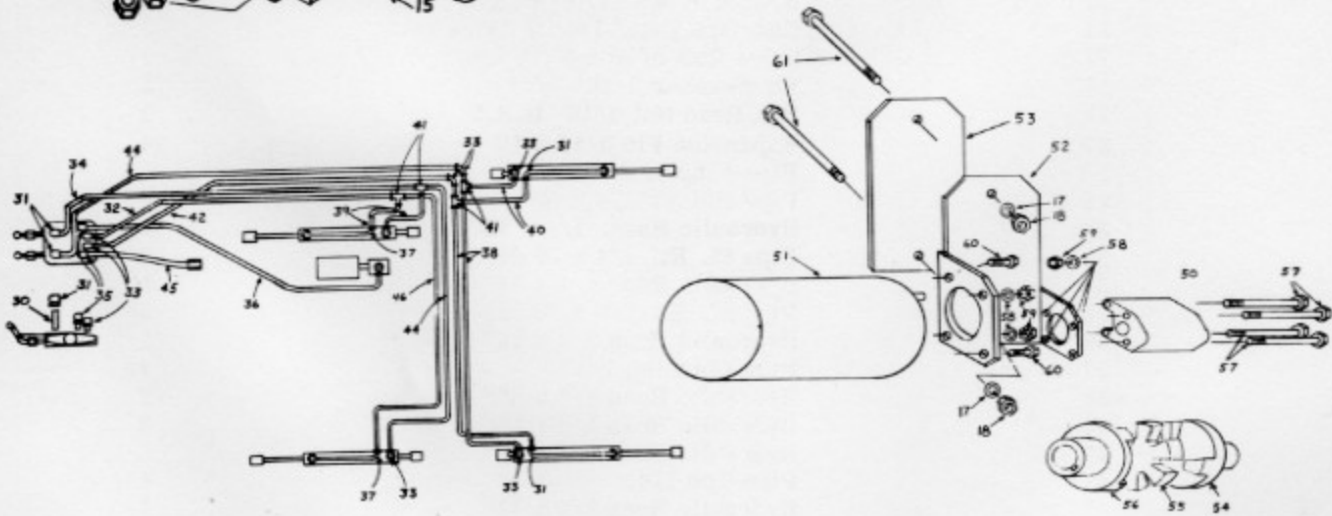
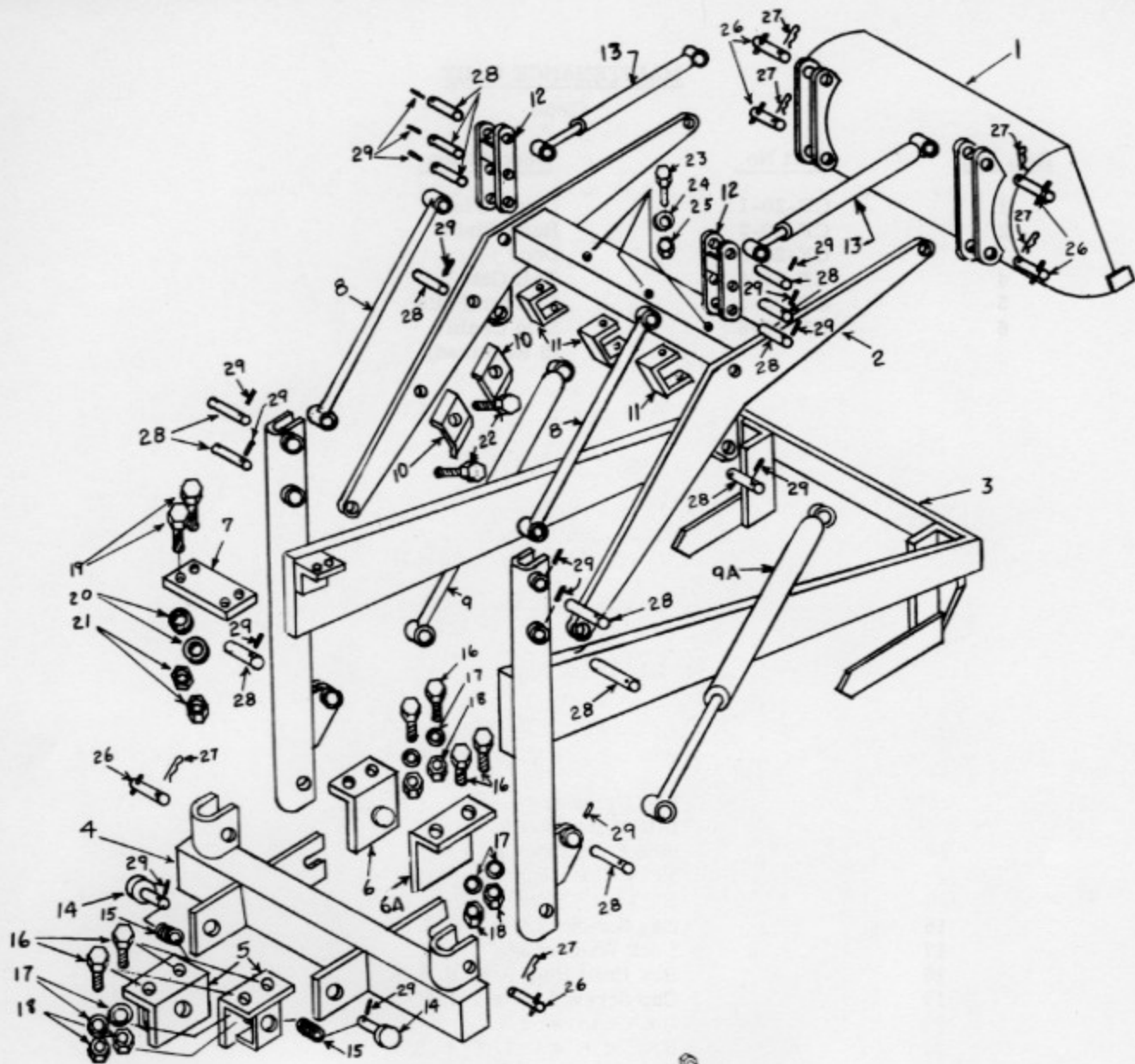

## BUCKET LOADER

Model AL40

When ordering parts, always specify the model number, quantity and description.

Send orders direct to:

- (1) Super Hydraulic  
Fort Dodge, Iowa  
  
Phone: (515) 576-1197
- (2) Omco Products  
P. O. Box 328  
Springfield, Ohio  
  
Phone: (513) 323-7586
- (3) Hahn Hydraulics Inc.  
1760 State Street  
Racine, Wisconsin 53401  
  
Phone: (414) 637-5658
- (4) E10 Drive Motor

<u>Source</u>	<u>Ref. No.</u>	<u>Part No.</u>	<u>Description</u>	<u>No. Req'd.</u>
(1)	9		Lift Cylinder - Left	1
(1)	9A		Lift Cylinder - Right	1
	10		Side Hose Clamp	2
	11		Front Hose Clamp	3
(1)	13		Bucket Cylinder	2
	16		Cap Screws 3/8 x 1 U. S. S.	8
	17		Lock Washer 3/8"	10
	18		Hex Head Nut, 3/8" U. S. S.	10
	19		Cap Screw 1/4" x 1-1/2"	3
	20		Lock Washer 1/4"	3
	21		Hex Head Nut, 1/4" U. S. S.	3
	22		Carriage Bolt, 1/4" x 2-3/4"	2
	23		Stove Bolt 3/16 x 4" U. S. S.	3
	24		Lockwasher 3/16"	3
	25		Hex Head Nut 3/16" U. S. S.	3
	29		Expansion Pin 3/16 x 1"	14
	30		Pipe Nipple, 1/4 x 2"	2
	31		Pipe Elbow, 1/4 x 90 deg.	4
	32		Hydraulic Hose, 1/4 x 32"	1
	33		Pipe St. El. 1/4 x 90 deg.	8
	34		Hydraulic Hose 1/4 x 34"	1
	35		Pipe St. El. 3/8 x 90 deg.	2
	36		Hydraulic Hose 3/8 x 36"	1
	37		Pipe Coupling 1/4"	2
	38		Hydraulic Hose 1/4 x 38"	2
	39		Hydraulic Hose 1/4 x 12"	2
	40		Hydraulic Hose 1/4 x 16"	2
	41		Pipe Tee 1/4"	4
	42		Hydraulic Hose 1/4 x 42"	1

<u>Source</u>	<u>Ref. No.</u>	<u>Part No.</u>	<u>Description</u>	<u>No. Req'd.</u>
(2)	43		Valve	1
	44		Hydraulic Hose 1/4 x 44"	2
	45		Hydraulic Hose 3/8 x 19"	1
	46		Hydraulic Hose 1/4 x 46"	1
(3)	50		Hydraulic Pump	1
(4)	51	178B8244P1	Electric Motor	1
	52		Motor and Pump Bracket	1
	54		Coupling Body, 7/16 bore	1
	56		Coupling Body 7/8 bore	1
	57		Hex Head Bolt, 5/16" x 4 N. C.	4
	58		Lockwasher, 5/16"	6
	59		Hex Head Nut, 5/16" N. C.	4
	60		Hex Head Bolt, 5/16" x 1 N. C.	2
	61		Hex Head Bolt, 3/8" x 2-1/2 N. C.	2

GENERAL ELECTRIC HOUSEWARES SERVICE CENTERS

NORTH ATLANTIC

Pennsauken, N.J.	08101	7100 Airport Hwy.	F.A. Frumento	(665-0440)
Baltimore, Md.	21234	6910 Harford Road	C.J. Cabral	(444-6600)
Boston, Mass.	02134	215 Brighton Avenue	N.D. Garant	(782-7511)
Bridgeport, Conn.	06610	2126 Boston Ave.	C.A. Clark	(335-3105)
Brooklyn, N.Y.	11201	38 Bond St.	R.E. Pandolfi	(852-0011)
Broomall, Pa.	19008	700 Parkway So., Lawrence Indl. Park	J.P. Sullivan	(353-3836)
Latham, N.Y.	12110	7 Herbert Drive So.	J.E. Plunkett	(785-5186)
New York, N.Y.	10017	Grand Central Terminal	W.F. Braidic	(689-6343)
Philadelphia, Pa.	19149	2010 Levick Street	R.R. Filoso	(288-4700)
Pittsburg, Pa.	15224	4319 Penn Avenue	M.R. LaRue	(621-5334)
Reading, Mass.	01867	100 Main Street	R.F. Welch	(944-6770)
Washington, D.C.	20007	1805 Wisconsin Ave., N.W.	G. Collini	(234-7404)
Yonkers, N.Y.	10704	5 Xavier Dr. (Cross Co. Shop. Ctr.)	A. Barbieri	(476-8400)

SOUTHEAST

Atlanta, Ga.	30318	1777 Ellsworth Ind. Dr., N.W.	J.L. Lipham	(355-3480)
Memphis, Tenn.	38103	669 Madison Avenue	M.P. Williams	(525-6789)
Miami, Fla.	33145	2151 S.W. 27th Avenue	W.H. Payne	(443-2543)
Nashville, Tenn.	37206	508 Main Street	R.C. Pigg	(244-7424)
Norfolk, Va.	23502	4552 East Princess Anne Road	H.A. Spiva	(855-3171)
Richmond, Va.	23230	4011 W. Broad Street	R.J. Shiembob	(353-5508)
Tampa, Fla.	33609	3602 W. Kennedy Blvd.	L.A. Gilbert	(877-6001)

MIDWESTERN

Chicago, Ill.	60641	Cor. Kilbourn & Milwaukee Aves.	R.P. Russe	(282-2110)
Cleveland, Ohio	44114	1435 E. 17th St.	N.G. Oriold	(241-5414)
Columbus, Ohio	43222	479 W. Broad Street	R.J. Misunas	(224-4118)
Detroit, Mich.	48227	13300 Puritan Avenue	D.H. Baughman	(342-6151)
Evanston, Ill.	60201	1567 Sherman Avenue	M.J. Marcanto	(328-9310)
Hammond, Ind.	46324	7324 Indianapolis Blvd.	J.R. Metteal	(845-2200)
Indianapolis, Ind.	46202	1827 N. Meridian Street	R. Schoomer	(924-1386)
Milwaukee, Wisc.	53218	6106 W. Fond Du Lac Avenue	S.J. Auerbach	(464-0950)
Omaha, Nebr.	68131	3724 Farnam Street	L.P. Wattenbarger	(341-3620)
St. Louis, Mo.	63139	2355 Hampton Avenue	F.L. Coonce	(647-6016)
St. Paul, Minn.	55114	2225 University Avenue	R.L. Butler	(645-9371)

SOUTHWEST

Dallas, Texas	75207	961 Dragon Street (Serv. Distr. Ctr.)	V.P. Platt	(742-7121)
Denver, Colo.	80204	975 Federal Blvd.	D.A. Hightower	(255-4616)
El Paso, Texas	79925	6591 Montana Street	B.L. Rosenbaum	(772-3256)
Houston, Texas	77027	2930 Hillcroft Avenue	R.C. Elliott	(785-5536)
Kansas City, Mo.	64108	2619 McGee Trafficway	B.R. Hall	(842-6690)
Metairie, La.	70002	3300 No. Causeway Blvd.	W.W. Parrie	(834-9080)
Oklahoma City, Okla.	73106	719 No. Virginia Avenue	G.J. Goggans	(236-4581)
San Antonio, Texas	78212	1902 McCullough Avenue	T.O. King	(733-9127)

WESTERN

San Jose, Calif.	95112	1727 North First Street	T.E. Gathier	(298-4203)
Long Beach, Calif.	90804	E. Pacific Coast Hwy.	W.G. Paine	(597-4301)
Los Angeles, Calif.	90057	2800 Beverly Blvd.	C.W. Benschopf	(385-3044)
Oakland, Calif.	94606	1045 E. 12th Street	R.A. Hoffer	(451-6642)
Pasadena, Calif.	91107	3486 East Foothill Blvd.	R.E. Turek	(792-7153)
Phoenix, Ariz.	85006	1733 E. McDowell Road	J.D. Wiley	(252-7663)
Portland, Ore.	97214	2137 E. Burnside Street	G.E. Barlow	(235-6682)
Sacramento, Calif.	95815	1785 Arden Way (Arden Fair Shop. Ctr.)	F.W. Ryman	(927-2246)
San Diego, Calif.	92108	1990 Camino Del Rio, No.	J.M. Winfrey	(291-2220)
San Francisco, Calif.	94103	1090 Bryant Street	P. Krakowski	(863-8921)
Seattle, Wash.	98121	2905 Third Avenue	H.E. Taft	(624-3171)

MOTORS

TABLE OF CONTENTS

Mower Motors	17-2
E8, E10, E12 Drive Motors	17-5
Drive Motor, E12 and E12M	17-7
Accessory Motors	17-9
Fork Lift Motor	17-11
Motor Identification	17-12

Part Number	Description	Motor Number and Part Number
1	Blade and Mount Assy (Blade Length-2 1/2 in.)	244220010
2	Blade and Mount Assy (Blade Length-3 1/2 in.)	244220020
3	Blade and Mount Assy (Blade Length-4 1/2 in.)	244220030
4	Blade and Mount Assy (Blade Length-5 1/2 in.)	244220040
5	Blade and Mount Assy (Blade Length-6 1/2 in.)	244220050
6	Blade and Mount Assy (Blade Length-7 1/2 in.)	244220060
7	Blade and Mount Assy (Blade Length-8 1/2 in.)	244220070
8	Blade and Mount Assy (Blade Length-9 1/2 in.)	244220080
9	Blade and Mount Assy (Blade Length-10 1/2 in.)	244220090
10	Blade and Mount Assy (Blade Length-11 1/2 in.)	244220100
11	Blade and Mount Assy (Blade Length-12 1/2 in.)	244220110
12	Blade and Mount Assy (Blade Length-13 1/2 in.)	244220120
13	Blade and Mount Assy (Blade Length-14 1/2 in.)	244220130
14	Blade and Mount Assy (Blade Length-15 1/2 in.)	244220140
15	Blade and Mount Assy (Blade Length-16 1/2 in.)	244220150
16	Blade and Mount Assy (Blade Length-17 1/2 in.)	244220160
17	Blade and Mount Assy (Blade Length-18 1/2 in.)	244220170
18	Blade and Mount Assy (Blade Length-19 1/2 in.)	244220180
19	Blade and Mount Assy (Blade Length-20 1/2 in.)	244220190
20	Blade and Mount Assy (Blade Length-21 1/2 in.)	244220200

MOWER MOTOR

Part Nos. 155C8075P1  
 155C8086P1  
 158C9011P1  
 158C9017P1  
 541C971P1

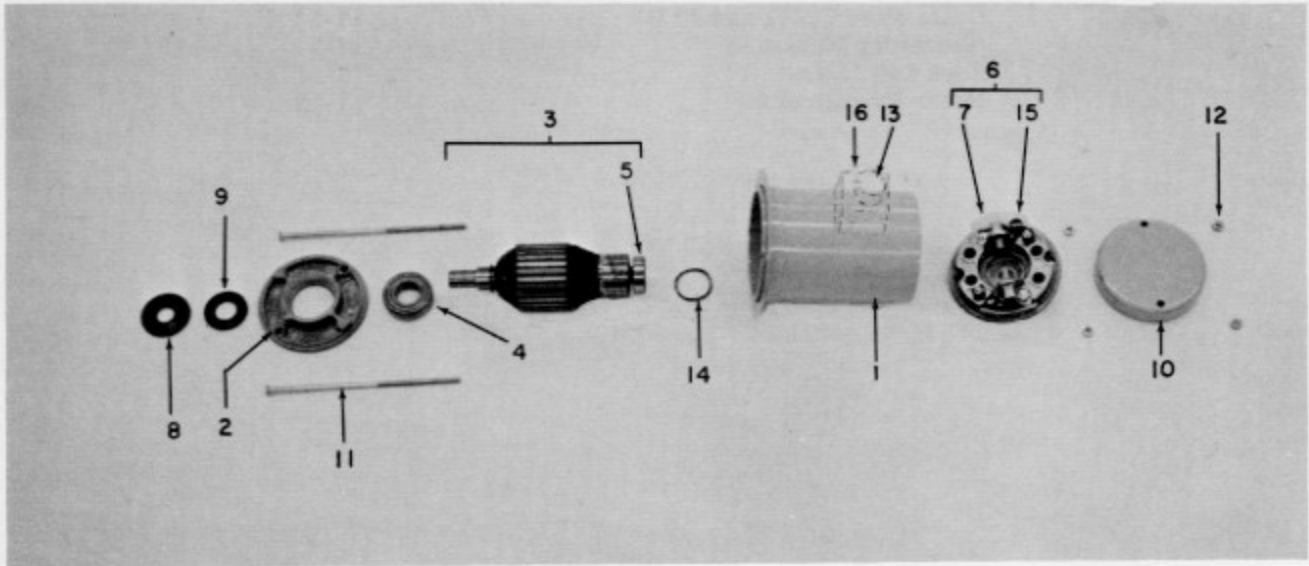

Ref. No.	Motor Number and Part Number					Description
	155C8075P1	155C8086P1	158C9011P1	158C9017P1	541C971P1	
1	244A7329P14	244A7329P21	244A7329P26	244A7329P19	244A7329P1	Shell and Magnet Asm. (Magnet Height-2.32 In.)
1					244A7329P31	Shell and Magnet Asm. (Magnet Height-2.0 In.)
2	244A7329P2	244A7329P2	244A7329P2	244A7329P2	244A7329P2	Shaft End Bell with Bearing, Ref. 4
3					244A7329P3	Armature & Bearing Asm., Ref. 4 & 5
3	244A7329P15	244A7329P22	244A7329P27	244A7329P15	244A7329P32	(Magnetic Height-2.32 In.) Armature & Bearing Asm., Ref. 4 & 5
4	244A7329P4	244A7329P4	244A7329P4	244A7329P4	244A7329P4	(Magnetic Height-2.0 In.) Shaft End Bearing
5	244A7329P5	244A7329P5	244A7329P5	244A7329P5	244A7329P5	Commutator End Bearing
6	244A7329P6	244A7329P6	244A7329P28	244A7329P6	244A7329P6	Com. End Bell Asm. (With Brushes) Ref. 7 & 15
7	244A7329P7	244A7329P7	244A7329P29	244A7329P7	244A7329P7	Brush Asm.
8	244A7329P8	244A7329P8	244A7329P8	244A7329P8	244A7329P8	External Bearing Shield
9	244A7329P9	244A7329P9	244A7329P9	244A7329P9	244A7329P9	Internal Bearing Shield
10	244A7329P16	244A7329P16	244A7329P10	244A7329P10	244A7329P10	Terminal Cover
11	244A7329P17	244A7329P23	244A7329P30	244A7329P20	244A7329P11	Tie Bolt
12	244A7329P12	244A7329P12	244A7329P12	244A7329P12	244A7329P12	Twin Whiz Lock Nut (1/4-20)
13	211A3530P1	211A3530P2	247A7390P2	247A7390P1	247A7390P1	Circuit Breaker
14	244A7329P24	244A7329P24	244A7329P24	244A7329P24	244A7329P24	Thrust Washer (not illustrated)
15	244A7329P33	244A7329P33	244A7329P33	244A7329P33	244A7329P33	Brush Holder Spring
16		244A7329P34				C. B. Cover

**MOWER MOTOR**  
Part No. 211A3435G1

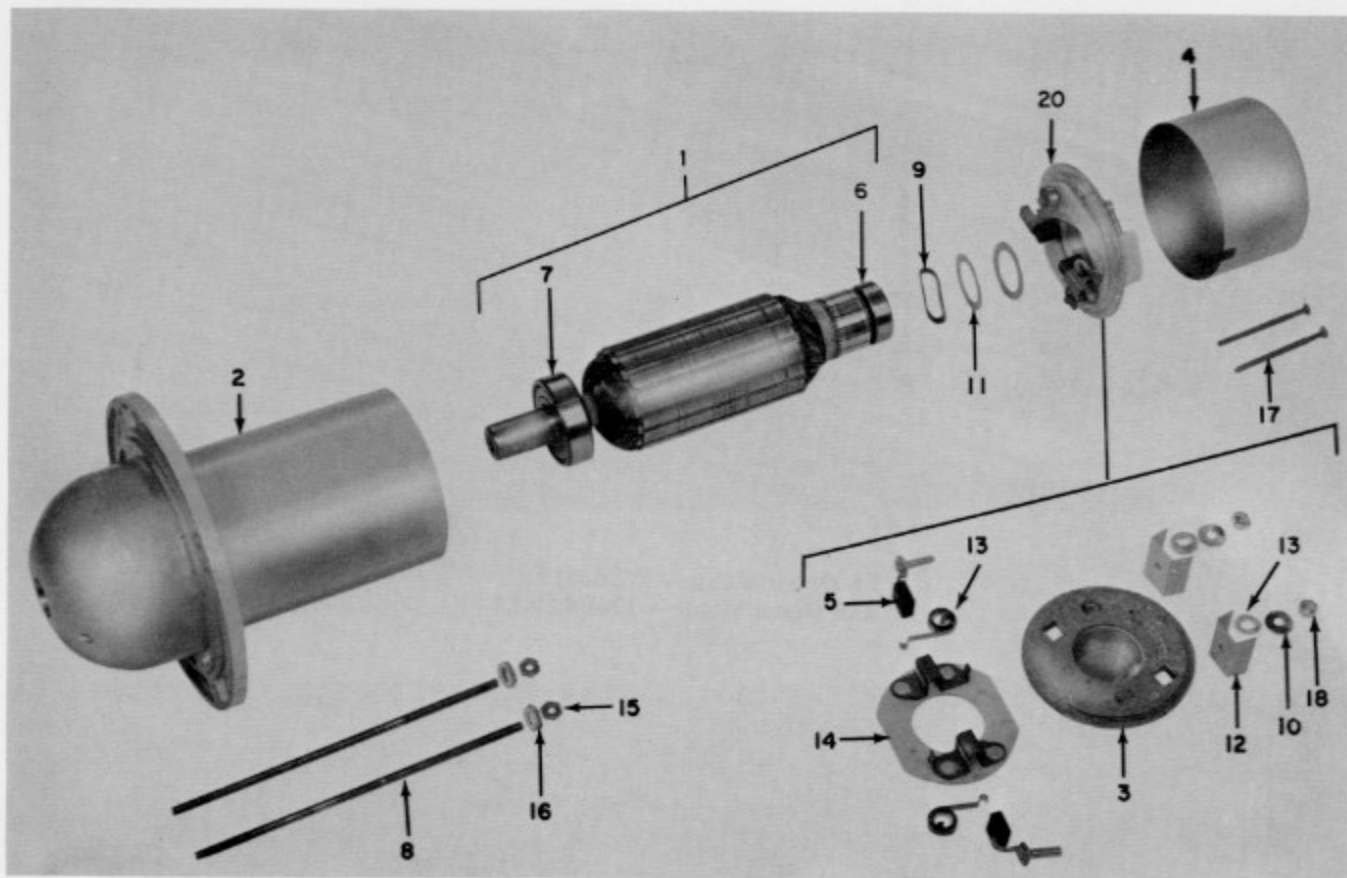

<u>Ref. No.</u>	<u>Part No.</u>	<u>Description</u>	<u>Reconditioned Part No.</u>
1	243A4736P1	Armature (with Bearings)	247A7666P1
2	243A4736P2	Drive End Shield and Stator Asm.	247A7666P2
3	243A4736P3	Commutator End Shield	247A7666P3
4	243A4736P4	Cover	247A7666P4
5	243A4736P5	Brush Asm.	--
6	243A4736P6	Commutator End Bearing	--
7	243A4736P7	Shaft End Bearing	--
8	243A4736P8	Clamp Screw	247A7666P5
9	243A4736P9	Spring Washer	--
10	243A4736P10	Steel Washer	--
11	243A4736P11	Shim Washer	--
12	243A4736P12	Insulator	--
13	243A4736P13	Brush Spring	--
14	243A4736P14	Brush Holder and Yoke	247A7666P6
15	243A4736P15	Clamp Screw Nut	--
16	243A4736P16	Clamp Screw Washer	--
17	243A4736P17	Cover Screw	--
18	243A4736P18	Yoke Nut	--
19	243A4736P19	Fiber Washer	--
20	243A4736P20	End Shield Asm.	247A7666P7

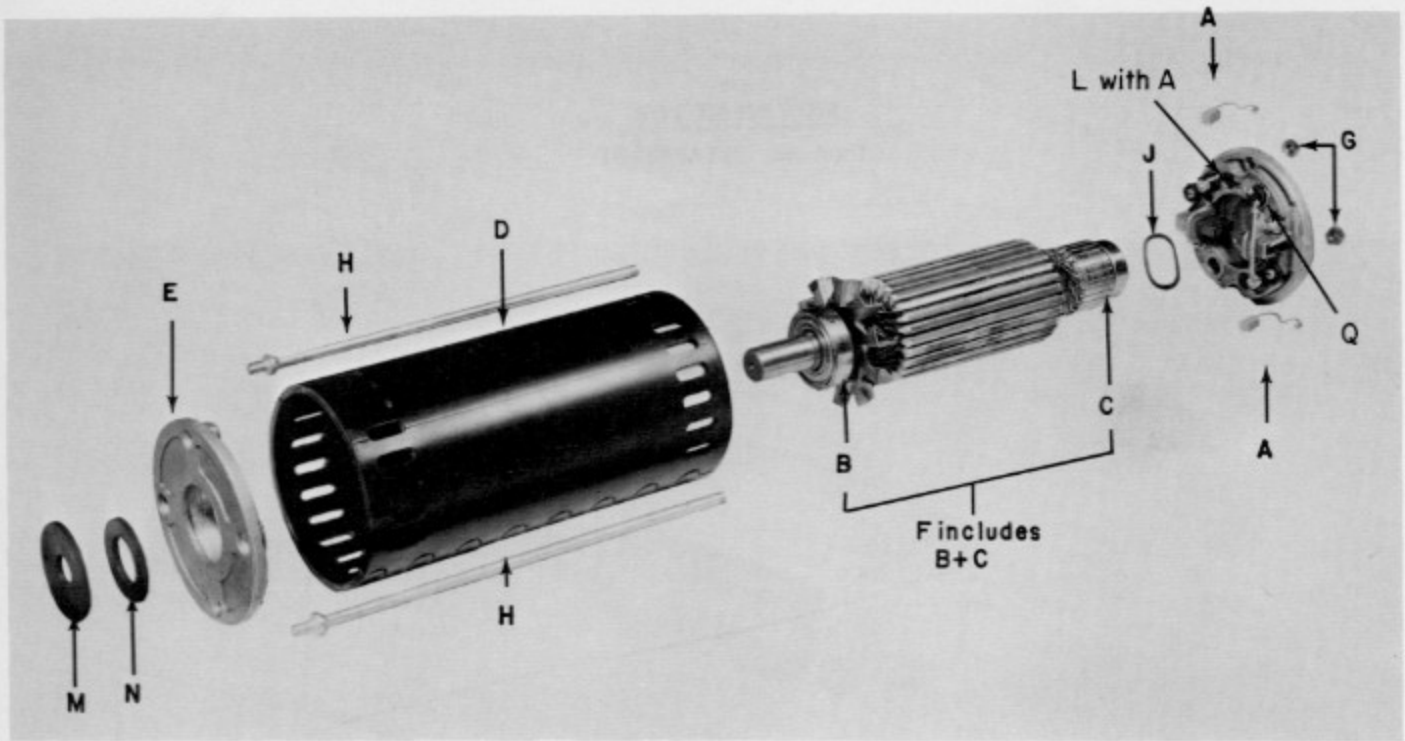

E8 Drive Motor - 178B8216P1  
 E10 Drive Motor - 178B8244P1

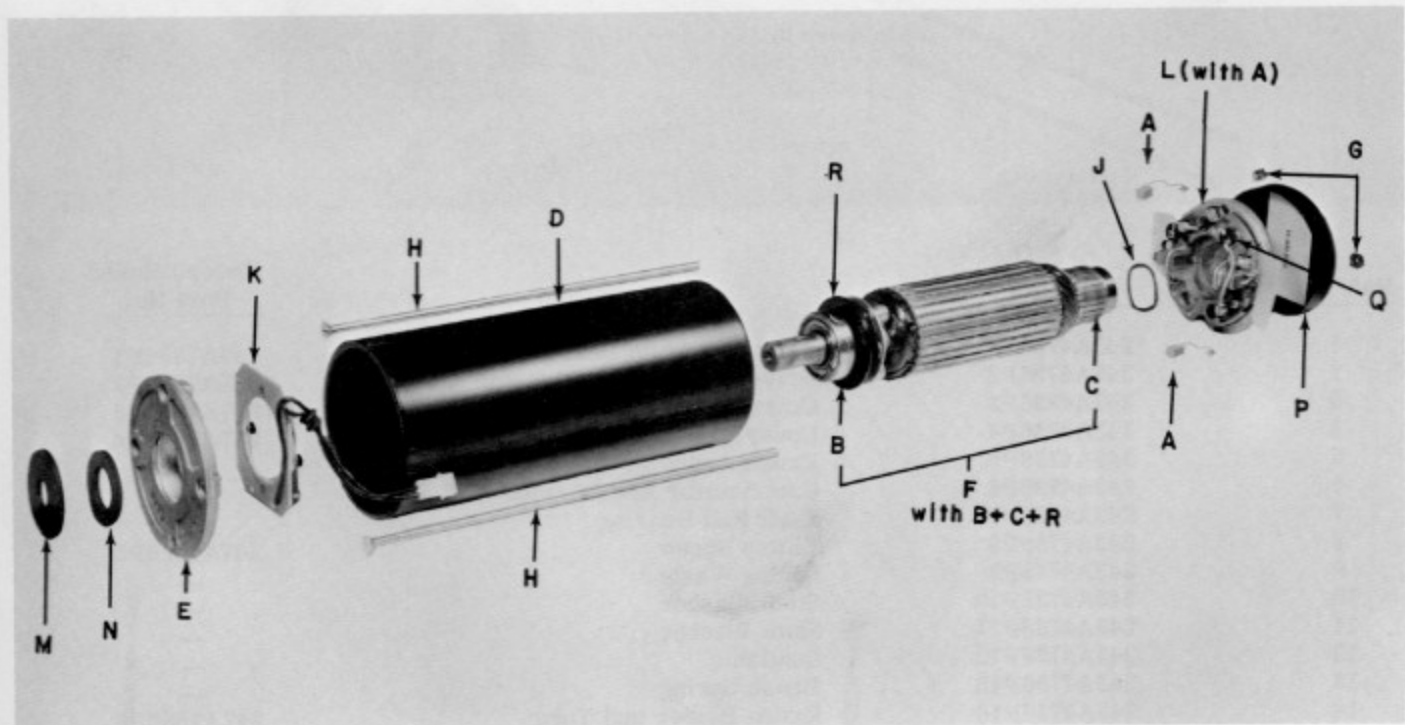

E12 Drive Motor - 163B9991P1

DRIVE MOTORS

Ref Letter	E12JA (And Later) 163B9991P1	178B8216P1	178B8244P1	Description
A	247A7513P1	247A7513P1	247A7513P1	Brush Assembly
B	244A7329P4	244A7329P4	244A7329P4	Drive End Bearing
C	244A7329P5	244A7329P5	244A7329P5	Commutator End Bearing
D	247A7513P4	247A7513P12	247A7513P18	Shell & Magnet Assembly
E	247A7513P5	247A7513P13	247A7513P13	Drive End Shield
F	247A7513P6*	247A7513P14**	247A7513P19**	Armature with Bearings
G	247A7513P10	244A7329P12	244A7329P12	Locknut
H	247A7513P8	247A7513P16	247A7513P16	Tie Bolt
J	244A7329P24	244A7329P24	244A7329P24	Thrust Washer
K	247A7513P11	---	---	Switch Assembly
L	247A7513P15	247A7513P15	247A7513P15	Com. End Shield
M	247A7513P17	247A7513P17	247A7513P17	Brush & Thermostat
N	247A7513P20	247A7513P20	247A7513P20	External Bearing Shield
P	247A7513P21	---	---	Internal Bearing Shield
R	247A7513P22	---	---	Cover
Q	247A7513P24	247A7513P24	247A7513P24	Switch Actuator
	* With Actuator			Circuit Breaker Assembly
	** With Fan			

RECONDITIONED  
DRIVE MOTORS

E8 order 247A7750P1 to replace 178B8216P1  
 E10 order 247A7750P2 to replace 178B8244P1  
 E12 & E12M order 247A7751P1 to replace 178B8034P1  
 E12JA & JD only order 247A7750P3 to replace 163B9991P1  
 E14 order 247A7750P3 to replace 163B9991P1  
 E15 & E12S order 247A7667P1 to replace 163B9862P1  
 E16 order 247A7667P1 to replace 163B9862P1  
 E20 order 247A7670P1 to replace 163B9996P1

BRUSH RELEASE HOLES  
2 HOLES 180° APART  
APPROX. 1 1/4 INCHES  
FROM END OF MOTOR

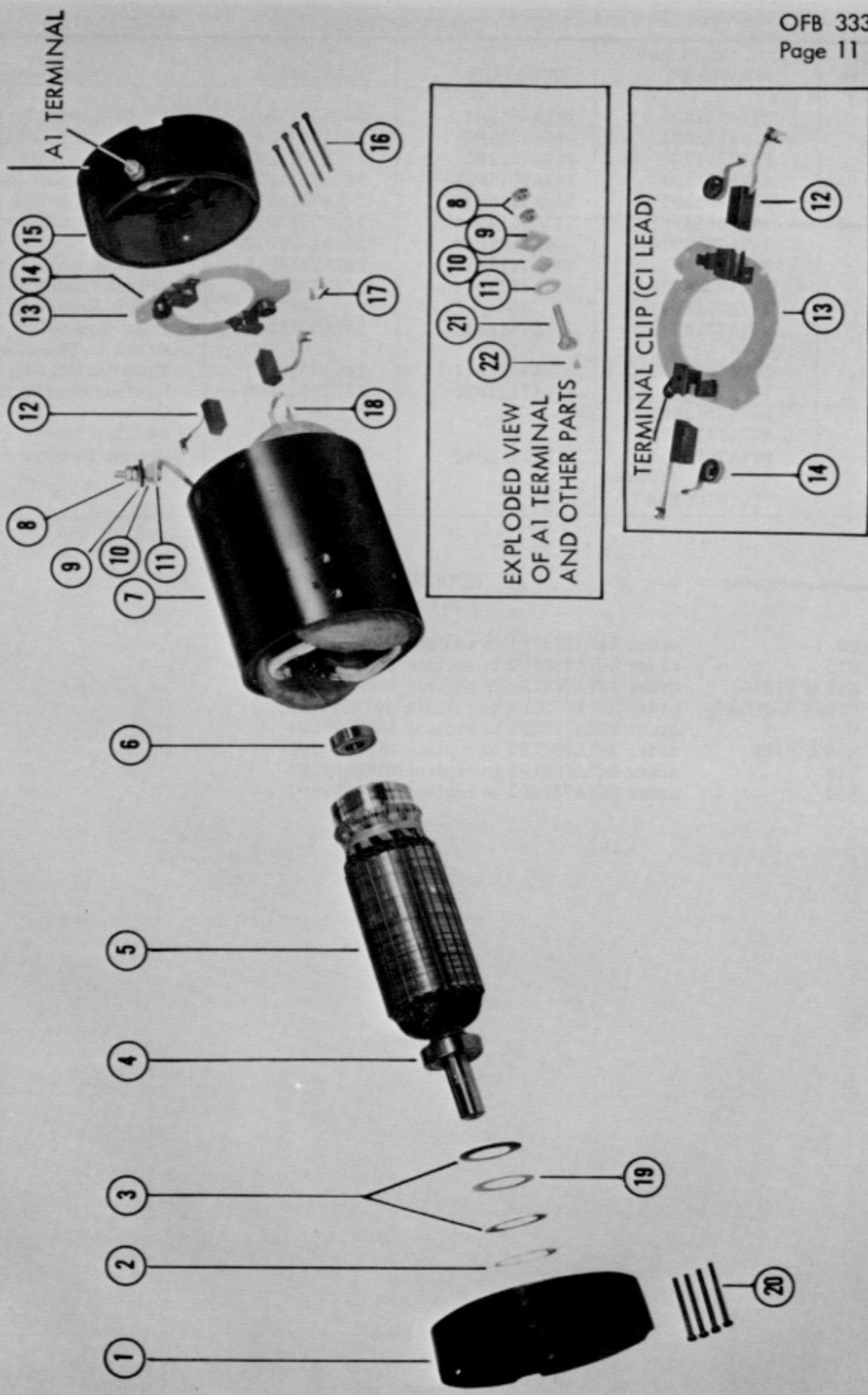

178B8034P1  
DRIVE MOTOR

<u>Ref. No.</u>	<u>Part No.</u>	<u>Description</u>
1	243A4735P14	End Shield, Shaft End
2	243A4735P15	Shim Washer
3	243A4735P16	Spring Washer
4	243A4735P17	Ball Bearing, Shaft End
5	243A4735P18	Armature (less Bearings)
6	243A4735P19	Ball Bearing, Comm. End
7	243A4735P20	Stator
8	N210P23B	Terminal Nut
9	243A4735P22	Spacer
10	243A4735P23	Bushing
11	243A4735P24	Spacer
12	243A4735P4	Brush Asm.
13	243A4735P11	Brush Rigging
14	243A4735P14	Brush Spring
15	243A4735P25	Endshield, Commutator End
16	N44P16044B11	Clamp Screw, Commutator End
17	N44P15007B	Brush Yoke Mounting Screw
18	N127P1508B	Terminal Screw
19	243A4735P29	Spacer Washer
20	N44P16032B11	Clamp Screw, Pulley End
21	243A4735P31	Terminal Screw
22	N44P15004B	Brush Screw
23	247A7831G1	Centrifugal Switch Kit (Not Shown)

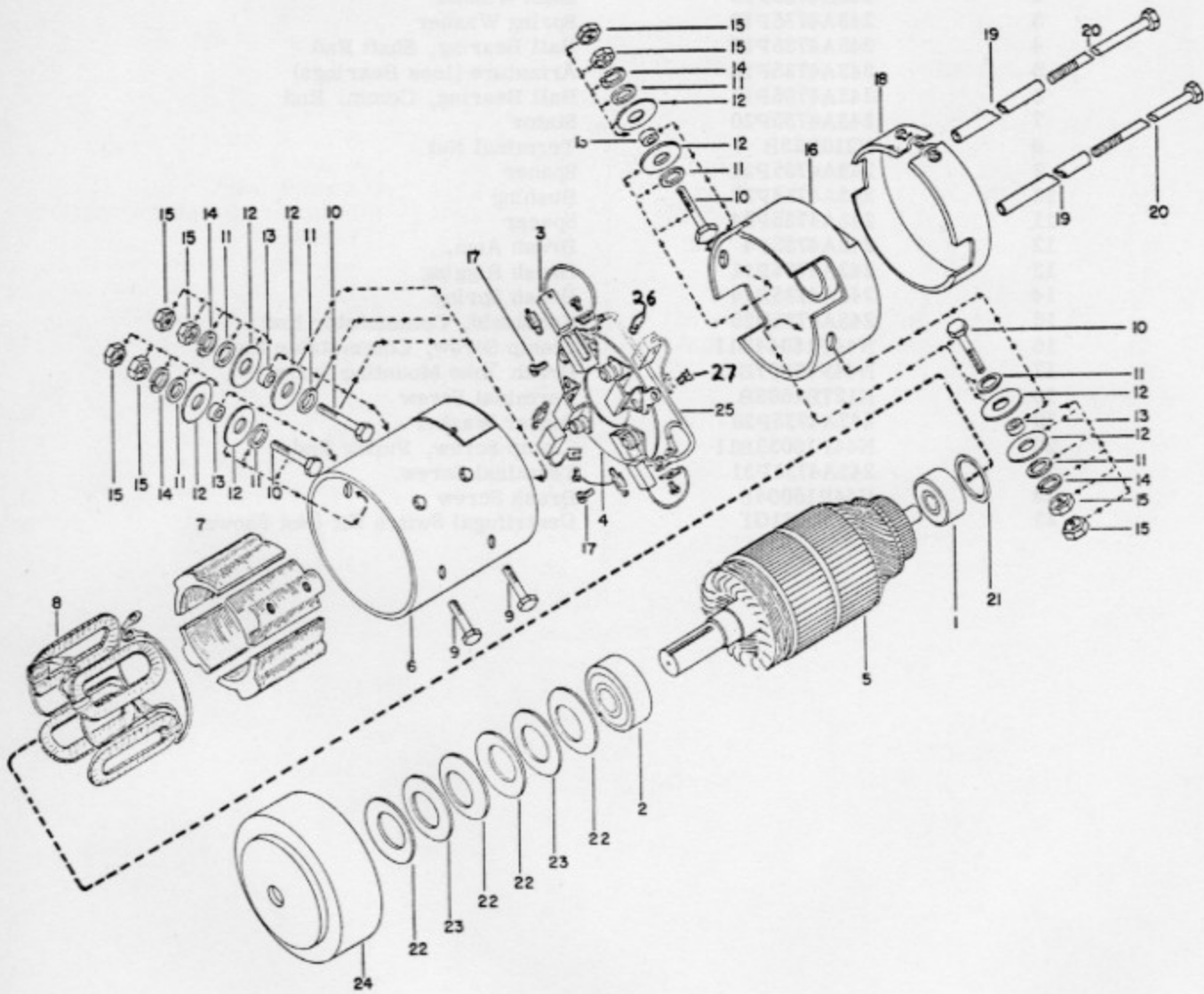

MOTOR SPARE PARTS

Ref. No.	163B9956P1	178B8170P1	178B8121P1	Description
	2 Roto-Tiller	AA42 Snow Throw	Trac-Vac CV60	
1	247A7792P1	247A7792P1	247A7792P1	Bearing, Ball (Comm. End)
2	247A7792P2	247A7792P2	247A7792P43	Bearing, Ball (Pulley End)
3	247A7792P3	247A7792P3	247A7792P3	Brush and Parts
4	247A7792P4	247A7792P4	247A7792P4	Brush Rigging
5	247A7792P28	247A7792P7	247A7792P34	Armature
6	247A7792P29	247A7792P8	247A7792P35	Stator Shell & Base
7	247A7792P9	247A7792P9	247A7792P9	Field Pole
8	247A7792P10	247A7792P10	247A7792P36	Field Coil Set
9	N22P21012B11	N22P21012B11	N22P21012B11	Screw-Pole Piece
10	N21P23024	N21P23024	N21P23024	Screw-Terminal
11	N402P12B11	N402P12B11	N402P12B11	Washer
12	247A7792P14	247A7792P14	247A7792P14	Washer Insul.
13	247A7792P15	247A7792P15	247A7792P44	Insulator, Bushing for Stator
14	N405P12B11	N405P12B11	N405P12B11	Lockwasher
15	N210P23B	N210P23B	N210P23B	Nut, Terminal Screw
16	247A7792P31	247A7792P16	247A7792P33	Endshield (Comm. End)
17	N51P15005B11	N51P15005B11	N51P15005B11	Screw - Brush Rigging
18	247A7792P32	247A7792P21	247A7792P38	Cover- Brush Access
19	247A7792P22	247A7792P22	247A7792P39	Insulation Tube
20	247A7792P23	247A7792P23	247A7792P40	Screw, Clamp
21	247A7792P16	247A7792P16	247A7792P16	Insulator, Bushing Shield C. E.
22	247A7792P24	247A7792P24	247A7792P24	Washer, Spring
23	247A7792P25	247A7792P25	247A7792P25	Washer, Spacer
24	247A7792P33	247A7792P26	247A7792P33	Endshield (Pulley End)
25	247A7792P27	247A7792P27	247A7792P27	Lead Asm.
26	247A7792P5	247A7792P5	247A7792P5	Brush, Spring
27	N67P16006	N67P16006	N6716004	Brush, Screw

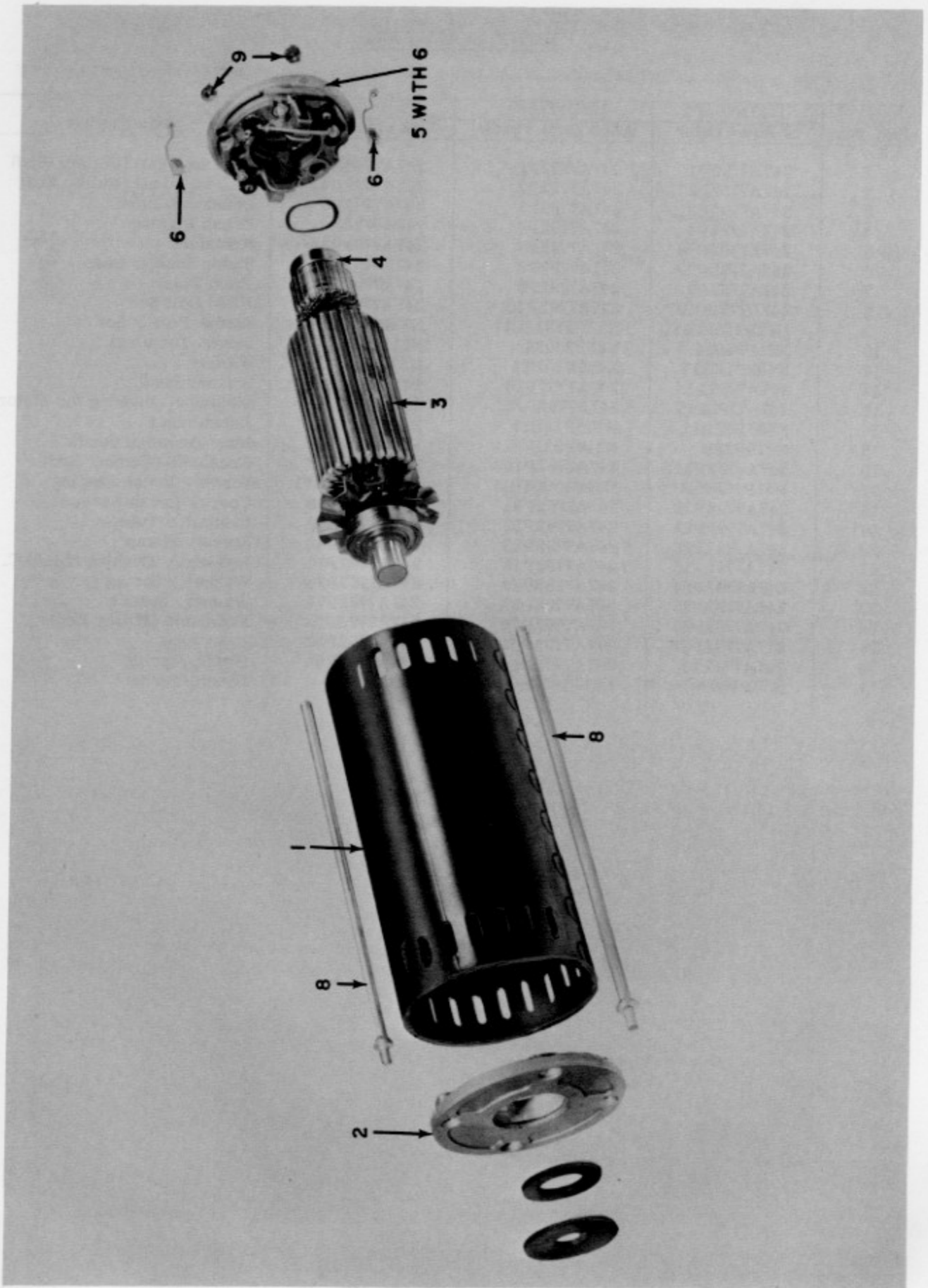

FORK LIFT MOTOR

<u>Ref. No.</u>	<u>Part No.</u>	<u>Description</u>
1		Shell & Magnet Asm., P1000-936
2		Drive End Shield, P1005-106
3		Armature & Bearing, P2012-22
4	244A7329P5	Comm. End Bearing, P2007-2
5		Comm. End Shield & Brushes, P1026-80
6	244A7329P7	Brush Asm., P1009-13
7		Term. Cover, P1033-49
8		Threaded Rod, H1-7
9	244A7329P12	Locknut, H2-27 1/4-20

Q	3	2	Q	Q	Q	Q	Q	Q
1	1	1	1	1	1	1	1	1
2	2	2	2	2	2	2	2	2
3	3	3	3	3	3	3	3	3
4	4	4	4	4	4	4	4	4
5	5	5	5	5	5	5	5	5
6	6	6	6	6	6	6	6	6
7	7	7	7	7	7	7	7	7
8	8	8	8	8	8	8	8	8
9	9	9	9	9	9	9	9	9
10	10	10	10	10	10	10	10	10
11	11	11	11	11	11	11	11	11
12	12	12	12	12	12	12	12	12
13	13	13	13	13	13	13	13	13
14	14	14	14	14	14	14	14	14
15	15	15	15	15	15	15	15	15
16	16	16	16	16	16	16	16	16
17	17	17	17	17	17	17	17	17
18	18	18	18	18	18	18	18	18
19	19	19	19	19	19	19	19	19
20	20	20	20	20	20	20	20	20
21	21	21	21	21	21	21	21	21
22	22	22	22	22	22	22	22	22
23	23	23	23	23	23	23	23	23
24	24	24	24	24	24	24	24	24
25	25	25	25	25	25	25	25	25
26	26	26	26	26	26	26	26	26
27	27	27	27	27	27	27	27	27
28	28	28	28	28	28	28	28	28
29	29	29	29	29	29	29	29	29
30	30	30	30	30	30	30	30	30
31	31	31	31	31	31	31	31	31
32	32	32	32	32	32	32	32	32
33	33	33	33	33	33	33	33	33
34	34	34	34	34	34	34	34	34
35	35	35	35	35	35	35	35	35
36	36	36	36	36	36	36	36	36
37	37	37	37	37	37	37	37	37
38	38	38	38	38	38	38	38	38
39	39	39	39	39	39	39	39	39
40	40	40	40	40	40	40	40	40
41	41	41	41	41	41	41	41	41
42	42	42	42	42	42	42	42	42
43	43	43	43	43	43	43	43	43
44	44	44	44	44	44	44	44	44
45	45	45	45	45	45	45	45	45
46	46	46	46	46	46	46	46	46
47	47	47	47	47	47	47	47	47
48	48	48	48	48	48	48	48	48
49	49	49	49	49	49	49	49	49
50	50	50	50	50	50	50	50	50
51	51	51	51	51	51	51	51	51
52	52	52	52	52	52	52	52	52
53	53	53	53	53	53	53	53	53
54	54	54	54	54	54	54	54	54
55	55	55	55	55	55	55	55	55
56	56	56	56	56	56	56	56	56
57	57	57	57	57	57	57	57	57
58	58	58	58	58	58	58	58	58
59	59	59	59	59	59	59	59	59
60	60	60	60	60	60	60	60	60
61	61	61	61	61	61	61	61	61
62	62	62	62	62	62	62	62	62
63	63	63	63	63	63	63	63	63
64	64	64	64	64	64	64	64	64
65	65	65	65	65	65	65	65	65
66	66	66	66	66	66	66	66	66
67	67	67	67	67	67	67	67	67
68	68	68	68	68	68	68	68	68
69	69	69	69	69	69	69	69	69
70	70	70	70	70	70	70	70	70
71	71	71	71	71	71	71	71	71
72	72	72	72	72	72	72	72	72
73	73	73	73	73	73	73	73	73
74	74	74	74	74	74	74	74	74
75	75	75	75	75	75	75	75	75
76	76	76	76	76	76	76	76	76
77	77	77	77	77	77	77	77	77
78	78	78	78	78	78	78	78	78
79	79	79	79	79	79	79	79	79
80	80	80	80	80	80	80	80	80
81	81	81	81	81	81	81	81	81
82	82	82	82	82	82	82	82	82
83	83	83	83	83	83	83	83	83
84	84	84	84	84	84	84	84	84
85	85	85	85	85	85	85	85	85
86	86	86	86	86	86	86	86	86
87	87	87	87	87	87	87	87	87
88	88	88	88	88	88	88	88	88
89	89	89	89	89	89	89	89	89
90	90	90	90	90	90	90	90	90
91	91	91	91	91	91	91	91	91
92	92	92	92	92	92	92	92	92
93	93	93	93	93	93	93	93	93
94	94	94	94	94	94	94	94	94
95	95	95	95	95	95	95	95	95
96	96	96	96	96	96	96	96	96
97	97	97	97	97	97	97	97	97
98	98	98	98	98	98	98	98	98
99	99	99	99	99	99	99	99	99
100	100	100	100	100	100	100	100	100

MOTORS

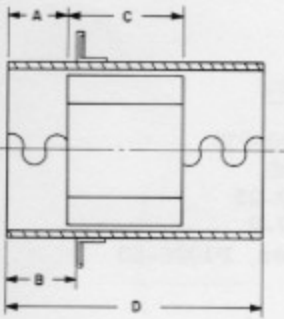

Shell Assembly

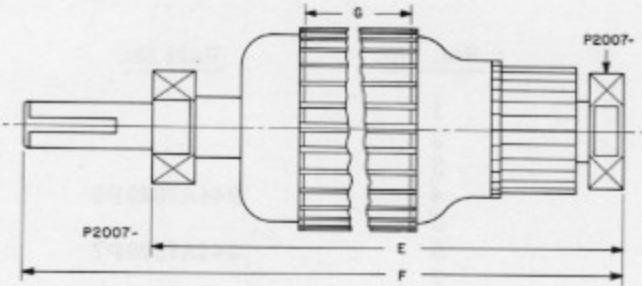
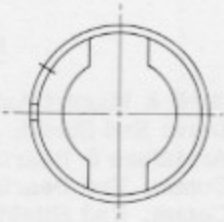

Armature-Bearing Assembly

GE Number	Model Number (used on)	A Inches	B Inches	C Inches	D Inches	E Inches	F Inches	G Inches
541C971P1	AA42	2 1/8	2 1/8	2	6 3/4	7 19/64	8 15/32	1 11/16
541C971P1	AA42	2 3/32	2 1/8	2 5/16	6 3/4	7 19/64	8 15/32	1 15/16
155C8075P1	AH42	1 1/2	2 7/8	2 1/16	5 15/16	6 31/64	7 21/32	1 15/16
155C8075P1	AH42	1 1/2	2 7/8	2	5 15/16	6 31/64	7 21/32	1 15/16
158C9017P1	AA42	1 1/2	2 3/8	2 1/16	5 15/16	6 31/64	7 21/32	1 15/16
155C8086P1	AH36	1 1/2	5/32	2 1/16	6 1/4	6 13/16	7 21/32	1 15/16
158C9011P1	AA42	1 13/32	--	5	8 7/8	8 19/64	9 15/32	2 15/16
178B8216P1	AE8	3 1/16	--	4	9 33/64	10 3/32	11 27/32	3 15/16
178B8244P1	AE10	1 29/32	--	5 1/16	9 33/64	10 3/64	11 27/32	4 15/16
191B4524P1	AM48	1 27/32	--	5 3/16	9 1/2	10 3/64	11 27/32	4 15/16
163B9991P1	AE12	2 9/16	--	5 1/2	10 5/8	11 11/64	12 31/32	5 1/16
191B4522P1	CE12	2 1/2	--	6 3/16	11 1/32	11 19/32	11 5/8	5 7/16
178B8229P1	Fork Lift	1 13/32	--	2 1/16	5 15/16	6 17/32	6 5/8	1 15/16
211A3435G1	AA42	--	Stator has Bell-Shaped Housing			7 11/32	8 5/8	3 17/32

TERMINALS

RING TERM.	WIRE SIZE	STUD SIZE	ORDER NO.
	6	1/4	243A4541 P-5
	8	1/4	243A4541 P-4
	8	5/16	243A4541 P-7
	10-12	#10	243A4541 P-1
	10-12	1/4	243A4541 P-3
	10-12	5/16	243A4541 P-6
	16-14	#10	243A4541 P-8
	16-14	1/4	243A4541 P-9
	16-14	5/16	243A4541 P-10
	18	#10	243A4538 P-3
	18	1/4	243A4538 P-4
	18	5/16	243A4541 P-11











FASTON RECEPT.	WIRE SIZE	TAB SIZE	ORDER NO.
	18	.187	243A4533 P-1
	18-14	.250	243A4570 P-7
	14-12	.250	243A4822 P-2

SHUR PLUG	WIRE SIZE	WHERE USED	ORDER NO.
	18-16	BRAKE SW.	243A4640 P-1
	18-14	METER TERM.	243A4640 P-4
	18-16	BRAKE SW. (E-12M)	244A7342 P-1

PIN, SOCKET CONTACTS	WIRE SIZE	TYPE	ORDER NO.
	18-14	MATE-N-LOK PIN	243A4539 P-3
	2-18	MATE-N-LOK PIN	243A4539 P-2
	18-14	MATE-N-LOK SOCKET	243A4532 P-2
	—	MATE-N-LOK COM. TAB	243A4544 P-1
	14-10	PIN	247A7735 P-2
	14-10	SOCKET	247A7736 P-2
	18	CARD 4 CONTACT	243A4823 P-2
	18	CARD 15.3 CONTACT	243A4569 P-1
	12-6	CONTACT PIN	244A7093 P-1
	18-16	PIGGYBACK .187	247A7467 P-1
	18-14	PIGGYBACK .250	247A7467 P-6
	#10 STUD	FASTON TAB (250)	

SPLICES	WIRE SIZE	TYPE	ORDER NO.
	18-16	BUTT	247A7655 P-1
	16-14	BUTT	243A4595 P-1
	18-14	PARALLEL	243A4841 P-1
	12-10	80#BTAIL	243A4567 P-1

RING TERM.	WIRE SIZE	STUD SIZE	ORDER NO.
	6	5/16	243A4541 P-12

PIN, SOCKET HOUSINGS	DESCRIP.	ORDER NO.
	9 CIRCUIT FOR MATE-N-LOK PINS	243A4544 P-3
	12 CIRCUIT FOR MATE-N-LOK PINS	243A4544 P-4
	15 CIRCUIT FOR MATE-N-LOK PINS	243A4544 P-5
	9 CIRCUIT FOR MATE-N-LOK SOCKETS	243A4548 P-3
	12 CIRCUIT FOR MATE-N-LOK SOCKETS	243A4548 P-4
	15 CIRCUIT FOR MATE-N-LOK SOCKETS	243A4548 P-5
	2 CIRCUIT FOR MATE-N-LOK SOCKETS	243A4594 P-1
	2 CIRCUIT FOR MATE-N-LOK PINS	243A4400 P-1
	4 CIRCUIT FOR MATE-N-LOK SOCKETS	243A4594 P-3
	2 CIRCUIT FOR PIN (A-10 M4)	247A7137 P-1
	2 CIRCUIT FOR SOCKET (A-10 M4)	247A7138 P-1

CONTACT PIN (B-M4M) 244A7094

HOUSING BLUE P-1  
RED P-2  
BLACK P-3



CARD 4 CONNECTOR 17888013 P-3



## TERMINALS

### RING TERMINALS

<u>Use Part Number</u>	<u>Where Used</u>	<u>Replaces</u>
243A4541P5	Power Disconnect, E15 Shunt	243A4538P1, 211A3594P3, 321598
243A4541P4	PTO, Power Res., Drive Mtr (S. F.)	33461, 243A4538P1, 211A3594P2
243A4541P7	Contactors, Drive Motor (L. F.)	31808, 243A4538P2, 211A3594P5
243A4541P1	Charger Heat Sink, C. B. 2	31805, 243A4538P7, 211A3594P10
243A4541P3	Charger Stud	31772, 243A4538P1, 211A3594P1
243A4541P6	HTO Wire at Contactor Studs	31827, 243A4538P8, 211A3594P4
243A4541P8	Fuse Holder (some models)	34123, 211A3594P6
243A4541P9	Headlite, Lift Connections at Batteries	31256, 211A3594P7
243A4541P10	Same as 243A4541P9	31257, 243A4538P6, 211A3594P8
243A4538P3	Contactor Coils	---
243A4538P4	Pwr. Disconnect Meter Wires	---
243A4541P11	Contactor Studs	31252, 243A4538P5
243A4541P12	S. Thrower, Contactor, Tiller	33466

### FASTON TERMINALS

<u>Use Part Number</u>	<u>Where Used</u>	<u>Replaces</u>
243A4553P1	Relays, Throttle Switches	60972-2, 243A4570P1, 211A3594P13
243A4570P7	Switches, Lift Mtr., Fuse Panel	60631-1, 243A4570P1, 60628-1, 211A3594P11
243A4822P2	Switches, ER8 Fuse Panel	42844-1, 243A4570P6, 211A3594P12
247A7467P1	Relays for Extra Connections	---
247A7467P6	Switches for Extra Connections	---

### SHUR PLUG TERMINALS

<u>Use Part Number</u>	<u>Where Used</u>	<u>Replaces</u>
243A4660P1	Brake Switch (L. F.), Clutch Switch (S. F.)	---
243A4660P4	Fuel Level, Power Usage Meters	42473-2, 211A3594P18
243A7362P1	Brake Switch (some E12m)	---

### PIN, SOCKET CONTACTS

<u>Use Part Number</u>	<u>Where Used</u>	<u>Replaces</u>
243A4539P3	For Male Housings	60620-1, 243A4539P1, 211A3594P14
243A4539P2	For Male Housings	---
243A4552P2	For Female Housings	60619-1, 243A4552P1, 211A3594P15
243A4566P1	Throttle (E-15) Housing, Charger	60843-1
247A7735P2	ER8 Mower Harness-Male Housing	350391-1, 247A7735P1
247A7736P2	ER8 Mower Harness-Female Housing	350390-1, 247A7736P1
243A4823P2	Card 4 Edge Connector	350011-3, 243A4823P1
243A4569P1	Card 1, Card 3	*60826-1, *60156-2, *211A3594P16
244A7093P1	Rear PTO, Outlet Kit Housings	---

\*Do not use (brass)

L. F. - Large Frame (E12 to E20)  
S. F. - Small Frame (ER8, E8, E10)

TERMINALS (Cont'd)

SPLICES

<u>Use Part Number</u>	<u>Where Used</u>	<u>Replaces</u>
247A7655P1	Diode Retrofits	31818
243A4595P1	Rear Electric Lift Harness	---
243A4841P1	Horn, Taillight Kits	---
243A4567P1	Headlight Wires Splice	34865, 211A3594P19

PIN AND SOCKET HOUSINGS

<u>Use Part Number</u>	<u>Wire Harness Used</u>	<u>For Pin and Socket Part Number</u>
243A4564P3	Tractor Harnesses	243A4539P3, 243A4539P2
243A4564P4	Tractor Harnesses	243A4539P3, 243A4539P2
243A4564P5	Tractor Harnesses	243A4539P3, 243A4539P2
243A4568P3	Tractor Harnesses	243A4552P2
243A4568P4	Tractor Harnesses	243A4552P2
243A4568P5	Tractor Harnesses	243A4552P2
243A4596P1	Tractor Chassis Harness	243A4552P2
243A4600P1	E-8, E-10 Mower Harness, R. Lift	243A4539P3, 243A4539P2
243A4596P3	Chassis Harness for Drive Mtrs.	243A4552P2
247A7737P1	Mower Harness Kit	247A7735P2
247A7738P1	Mower Harness Kit	247A7736P2
244A7094P1	Receptacle Kits	244A7093P1
244A7094P2	Receptacle Kits	244A7093P1
244A7094P3	Receptacle Kits	244A7093P1
178B8013P3	Card 4 Edge Connector Housing	243A4823P2
247A7709P1	Housing - ER8 Mower Harness	247A7735P2
247A7762P1	Housing - ER8 Chassis Harness	247A7736P2

CROSS-REFERENCE

TABLE OF CONTENTS

Dash Harness	19-2
Grill Harness	19-3
Undercarriage Harness	19-4
Throttle Harness	19-5
Control Panel Harness	19-6
Installation and Operating Instructions	19-7



DASH HARNESS

	541C994G1	541C955G2	158C9052G1	541C920G1	541C955G1	541C967G1	155C8072G1	155C8136G1	155C8178G1	155C8132G1	158C9056G1										
E20AA																					
BA																					
CA																					
CB																					
CC																					
DA																					
EA																					
EC																					
ED																					
FA																					
RA																					
E16AA																					
RA																					
RB																					
RD																					
E15AA																					
BA																					
CA																					
CB																					
DA																					
EA																					
FA																					
GA																					
HA																					
JA																					
E14AA																					
RC																					
RD																					
RH																					
RJ																					
E12AA																					
BA																					
CA																					
DA																					
EA																					
HA																					
JA																					
JD																					
E10AA																					
BA																					
CA																					
DA																					
EA																					
E8AA																					
BA																					
CA																					
CC																					
DA																					
EA																					
CE20AA																					
BA																					
CA																					
DA																					

GRILL HARNESS

	155C8019G1	158C9053G1	541C924G1	541C958G1	155C8084G1	158C9006G1	541C958G2	541C944G1	155C8064G1	158C9007G1
E20AA										
BA										
CA										
CB										
CC										
DA										
EA										
EC										
ED										
FA										
RA										
E16AA										
RA										
RB										
RD										
E15AA										
BA										
CA										
CB										
DA										
EA										
FA										
GA										
HA										
JA										
E14AA										
RC										
RD										
RH										
RJ										
E12AA										
BA										
CA										
DA										
EA										
HA										
JA										
JD										
E10AA										
BA										
CA										
DA										
EA										
E8AA										
BA										
CA										
CC										
DA										
EA										
CE20AA										
BA										
CA										
DA										

UNDERCARRIAGE HARNESS

	423D275G1	127D8105G1	127D8099G1	127D8097G1	423D215G1	423D234G1	127D8011G1	127D8100G1	423D228G1	423D234G2	127D8003G1	127D8052G1	422D847G1	127D8074G1	127D8110G1	127D8117G1
E20AA																
BA																
CA																
CB																
CC																
DA																
EA																
EC																
ED																
FA																
RA																
E16AA																
RA																
RB																
RD																
E15AA																
BA																
CA																
CB																
DA																
EA																
FA																
GA																
HA																
JA																
E14AA																
RC																
RD																
RH																
RJ																
E12AA																
BA																
CA																
DA																
EA																
HA																
JA																
JD																
E10AA																
BA																
CA																
DA																
EA																
E8AA																
BA																
CA																
CC																
DA																
EA																
CE20AA																
BA																
CA																
DA																

# THROTTLE HARNESS

	178B8097G1	178B8480G1	158C9051G2	541C919G1	541C957G1	158C9051G1	158C9044G1	541C985G1	155C8065G1
E20AA	█								
BA	█								
CA									
CB									
CC									
DA									
EA		█							
EC									
ED									
FA									
RA									
E16AA			█						
RA									
RB									
RD									
E15AA				█					
BA									
CA									
CB									
DA									
EA									
FA									
GA									
HA						█			
JA			█						
E14AA							█		
RC								█	
RD									█
RH									
RJ							█		
E12AA				█					
BA									
CA									
DA									
EA									
HA									
JA									
JD								█	
E10AA									
BA									
CA									
DA									
EA									
E8AA									
BA									
CA									
CC									
DA									
EA									
CE20AA	█								
BA		█							
CA			█						
DA				█					



INSTALLATION AND OPERATING INSTRUCTIONS

MODEL	PUB. NO.	DESCRIPTION
AA42	GEZ-5080C	Rotary Mower (Set-Up and Operation)
AA42	GEZ-5086	Rear/Side Discharge
AB42	GEH-4007	42" Snow/Dozer Blade
AB48	GEZ-5081D	48" Snow/Dozer Blade
AG55	GEH-3961	Tractor Cab
AH42	GEH-3971A	E12M Mower
AP22-AP27	OPK-4012A	Mower Blade Kit
AP41	GEH-4002	E8M Accessory Outlet Kit
AP45	GEH-4024	Seat Spring Kit
AP50	GEH-3970	Sleeve Hitch
AP56	GEH-3953	Implement Mounting Bracket
AP54	GEH-4006	E8/E10 Implement Mounting Bracket
AP58	GEH-3954	Manual Rear Lift
AP59	GEH-3966	Rear Electric Lift
AP60	GEH-3959	Inverter (Electronic)
AP69	GEH-3960A	Horn Kit
AP70	GEH-3957A	Tail Light Kit
AP71	GEH-4003	E8, E10 Headlight Kit
AP84	GEH-4018B	Power Pack Booster
AP85	GEH-3951	Weight/Utility Box - Large Frame
AP86	GEH-3972	Weight/Utility Box - Small Frame
AP85/AP86	OPK-74-3	Dual Use Weight Box
AP90	GEH-3950A	Arc Welder
BL36	GEH-3965	Front Platform Lift
BC11	GEH-3958	Canopy Top
BD22	GEH-3955	Double Seat
BG33	GEH-3956	Golf Bag Holder
CF48, 74, 92	GEH-4015	Fork Lift Use and Care
CF48, 74, 92, } + CF65, CF66 }	GEH-4025	Fork Lift Assembly and Installation
E1	GEH-3973	Owner's Use and Care Manual - Mower
KA03	GEH-4009	Heavy-Duty Mower Motor Kit ( 42")
KB48	GEH-3997A	E12M Dozer Blade Adapter Kit
KD10	OPK-4001A	E10M PTO Outlet Kit
KD38	GEH-4008A	Speed Reduction Kit (S. F.)
KF08	GEH-4004	E8M Fuel Level Gage Kit
KM12	GEH-4005A	E12M Heavy-Duty Transaxle Conversion Kit
KP37	GEH-4014A	Front/Rear Receptacle Kit (L. F.)
KS70	GEH-4023	Heavy-Duty Spindle Kit
KT25	GEH-4020	E8M to E8HM Heavy-Duty Kit
-	GEH-3289	External Charging Kit
-	GEH-4030	E8/10 H. D. Harness (mower) Kit
-	GEH-3974	Motor Conversion (S. Thrower/Rototiller)
-	GEZ-5092A	Lift Strap Threading
-	GEZ-5313D	Large Frame Battery Installation
E8M, E10M	GEZ-5650	Owner's Use and Care Manual
-	GEZ-5651B	E8, E8HD, E10 S/U Instructions
ER8-36	OPS-74-4032	Owner's Use and Care Manual
E12M, E14, } E16, E20 }	GEZ-5919	Owner's Use and Care Manual