

10" MOLDBOARD PLOW

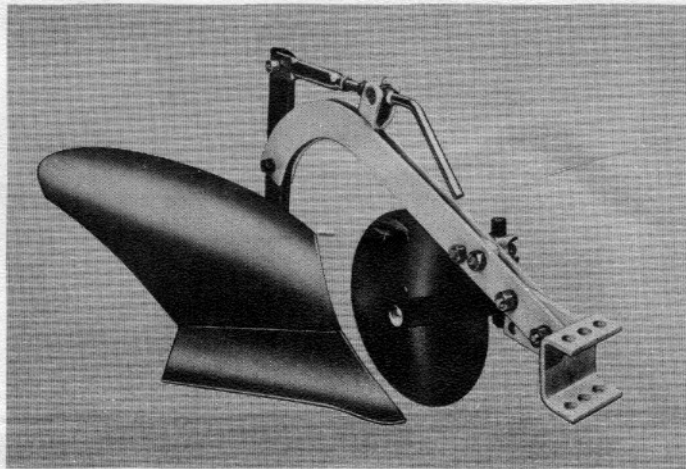

ASSEMBLY INSTRUCTIONS
OPERATING INSTRUCTIONS
and
PARTS LIST

PREPARING PLOW FOR USE:

The plow bottom must be cleaned so that dirt will slide off the moldboard without sticking. Wipe the polished surface with a rag soaked in turpentine, naphtha or gasoline. An old brick or a pumice stone can also be used to remove the protective coating, but usually this is not necessary if soil is not too wet.

In order to maintain a proper plowing cut width, refer to Figures A & B and chart.

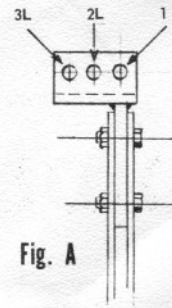

Fig. A
Top View Plow Yoke
With Yoke Assembled To Left Side

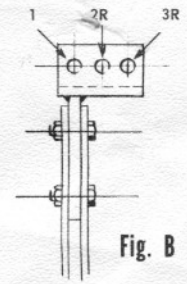

Fig. B
Top View Plow Yoke
With Yoke Assembled To Right Side

Measure inside distance between rear tractor wheels — refer to following chart for proper hitch attaching hole.

NOTE: When extreme plowing conditions are encountered (or whenever wide, high floatation tires are used) it may be desirable to reduce the width of plow cut. (For example, plow 8" or 9" wide with a 10" plow, or 10"-11" with a 12" plow.) This can be accomplished by hitching plow (1) or (2) holes over to left from recommended setting given in charts.

Inside Dim. Inches Between Rear Tractor Wheels	PLOW SIZE		
	8" PLOW	10" PLOW	12" PLOW
18"	USE HOLE #1 — FIG. A	USE HOLE #2R — FIG. B	
20"	USE HOLE #2L — FIG. A	USE HOLE #1—Fig. A or B	USE HOLE #3R — FIG. B
22"	USE HOLE #3L — FIG. A	USE HOLE #2L — FIG. A.	USE HOLE #2R — FIG. B
24"		USE HOLE #3L — FIG. A.	USE HOLE #1—Fig. A or B
26"			USE HOLE #2L — FIG. A
28"			USE HOLE #3L — FIG. A

DEPTH ADJUSTMENT

The plow point pitch or suck is controlled by depth control crank. Turning this crank clockwise will cause plow to go deeper, counter-clockwise shallower (Fig. C).

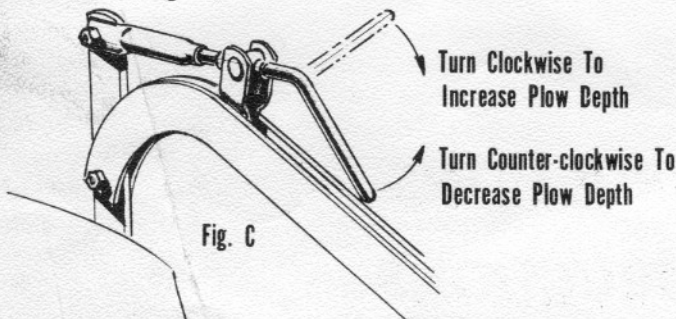

LANDING ADJUSTMENT

The plow bottom will react similar to a rudder while ground engaged. If plow point is too far from left of beam, plow will tend to over cut and leave a ragged furrow wall. This condition can be readily corrected by making the following adjustment:

Loosen 2 bolts attaching plow bottom to stand-ard — turn land adjusting bolt clockwise two turns — retighten plow bottom attaching bolts securely. Repeat adjustment as necessary until plow follows correctly and proper width of cut is reached. (Fig. D)

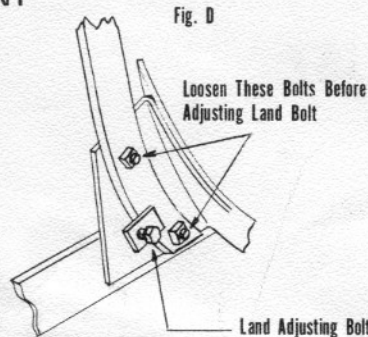

COULTER ADJUSTMENT

Coulter should be adjusted to slice 2"—3" deep. While making this adjustment, the coulter limit stop pin should also be set to prevent coulter from swinging into plow beam or bottom. If properly adjusted, coulter will be free to swing outward a limited amount from beam but will not be free to swing in to touch plow beam or bottom (Fig. E).

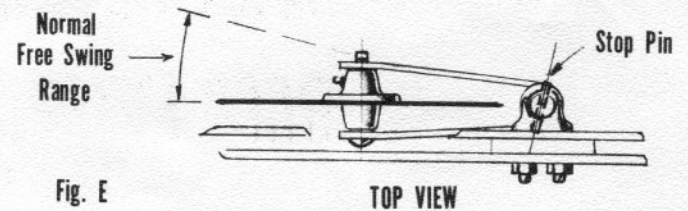

WHEN TO PLOW

Make sure the ground is in proper plowing condition before starting. Never plow when the soil is wet. If it is too dry, it will be difficult for the plow to penetrate the soil. Avoid low places, old roadways, paths and other places where the soil is overly packed. Expect to have trouble with a thick sod which has not been plowed in several years. However, by finding the correct setting at the coulter, the hitch and the turnbuckle, you should be able to do a satisfactory job under most conditions. High weeds or grass should be cut down with the rotary mower before plowing.

TO BEGIN PLOWING

This plow generally works best at a depth equal to about 1/2 of its cutting width, i.e., 8" plow 4"-5" deep, 10" plow 5"-6" deep, 12" plow 6"-7" deep.

To turn the plow point into the ground when opening the furrow, use the depth adjusting crank (Fig. C). Adjust plow point downward until a satisfactory penetration is accomplished. NOTE: Be sure tractor hitch is properly adjusted so as not to hold plow out of ground when tractor lift lever is lowered.

After the dead furrow has been made, level the plow by running the right tractor wheels in the previous furrow. Adjust depth control crank (Fig. C) until plow landside heel runs 1/4"-1/2" from bottom of furrow.

NOTE: When the right tractor wheels are in the furrow, the plow hitch is designed to level the plow in the proper horizontal angle.

Lay out your field to be plowed, and, if possible, make it rectangular in shape, about 3 times as long as it is wide. NOTE: It is easier to plow a few long furrows than many short ones. LEAVE SOME ROOM AT EACH END FOR TURNING YOUR TRACTOR. Start plowing by laying off a dead furrow as shown in the sketch below. (Fig. F)

Begin at point "X" and plow a furrow to the end of your plot. Fix your eyes on a tree or some distant object in line with the middle of the plow so that you can guide your tractor and plow a straight first furrow to point "A". NOTE: ALWAYS LIFT PLOW BEFORE TURNING, and, at point "B", lower it again and plow a dead furrow piling the dirt on top of dirt from the first furrow. When you return to point "X" and start your real plowing with both the tractor's right wheels in the furrow at point "C", level out the plow with the turnbuckle. Plow in a clockwise direction, always LIFTING your plow at the end of the furrow before turning.

SPEED

Do not plow too fast. Move steadily along so that the earth will turn over and not fall back into the furrow. In most soils, this is done at full throttle in first gear.

In light soils, plowing may often be done in second gear, but if you go too fast, you will get an uneven plowing job and the dirt is apt to be thrown instead of rolled over.

NOTE: When putting plow away, always wipe polished surface and coulter blade with grease or oil to prevent rust — replace badly worn plow shares.

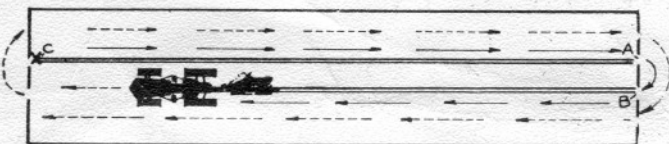

Fig. F

ASSEMBLY INSTRUCTIONS

PP-500 SERIES PLOW

FIG. 1. Assemble hitch assembly (A) to front of beam assembly (B) with bracket protruding right or left. (See **Preparing Plow For Use** instructions). Attach with two 5/8" x 1-3/4" hex bolts (C) and 5/8" lock nuts (D). Next drop trunnion (E) thru holder in beam assembly and insert crank assembly (F) thru hole in trunnion. Insert spacer (G) and two 5/8" jam nuts (H). Tighten until crank assembly is barely free to turn, then jam the nuts together. Attach threaded tube (J) to end.

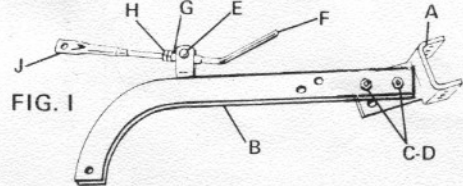

FIG. II. Remove 1/2" square nut (A) from plow bolt on landside of plow bottom. Install standard assembly (B) to plow bottom using existing 1/2" plow bolt at bottom and 1/2" x 1-1/2" carriage bolt (C) at top. Secure with two 1/2" square nuts. Insert 1/2" x 1-1/2" long hex bolt (D) thru land adjusting tab on standard. Fasten with 1/2" square nut (E) between standard and bottom.

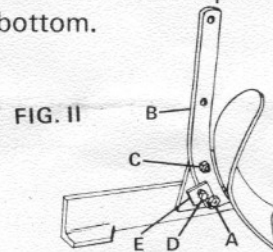

FIG. III. Straddle beam assembly (A) over standard (B) at lower hole and fasten with 1/2" x 1-3/4" long hex bolt (C) and 1/2" lock nut (D). Attach end of threaded tube (E) on crank assembly to upper hole of standard. Secure with 1/2" x 1-1/2" long hex bolt (F), 1/2" I.D. bushing (G) (in standard), 1/2" flat washer (H) (next to bushing) and 1/2" lock nut (J). Attach fork assembly (K) to coulter blade (L) using carriage bolt blank (M), 5/8" flat washers (N) (as needed) and 1/8" x 1-1/4" long cotter pin (P). Mount the completed coulter assembly to out side of plow beam using coulter clamp assembly (O). Refer to **Coulter Adjustment** instructions for setting.

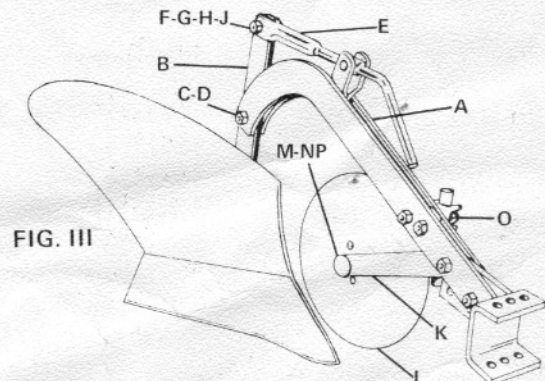
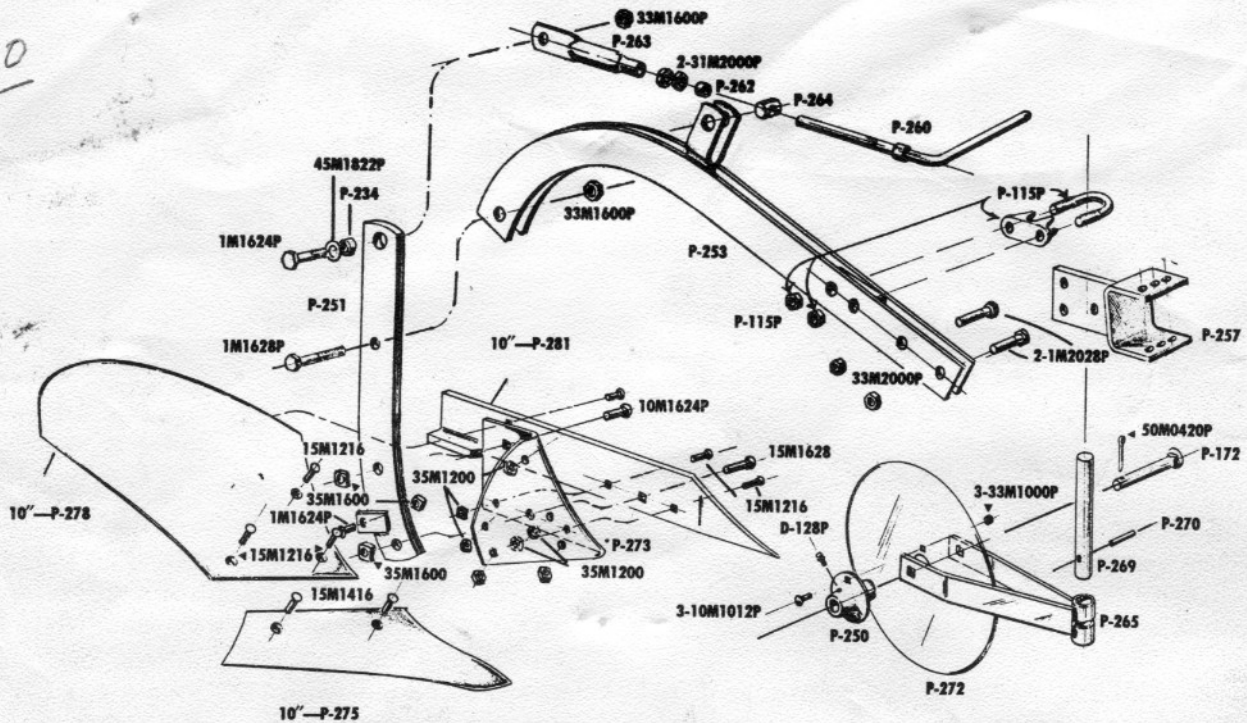

FIG. III

10" MOLDBOARD PLOW

94.50



Part No.	Description	Part No.	Description
P-115P	Coulter clamp assy.	1M1624P *	Hex bolt 1/2-13 x 1-1/2
P-172P	Carriage bolt blank	1M1628P *	Hex bolt 1/2-13 x 1-3/4
P-234	Bushing	1M2028P *	Hex bolt 5/8-11
P-250	Hub coulter	10M1012P *	Carriage bolt 5/16-18 x 3/4
P-251	Standard assy.	31M2000P *	Hex jam nut 5/8-11
P-253	Beam assy.	33M1000P *	Hex lock nut 5/16-18
P-257	Yoke assy.	33M1600P	Nut hex lock 1/2-13
P-260	Crank assy.	33M2000P	Nut hex lock 5/8-11
P-262	Spacer	35M1600 *	Sq. nut 1/2-13
P-263	Threaded lube	45M1822P	Plain washer 9/16 x 1-3/8
P-264	Trunnion	50M0420P *	Cotter pin
P-265	Fork assy.	P-273	Frog
P-269	Coulter standard	P-278	10" Moldboard
P-270	Drive type pin	P-281	10" Land assy.
P-272	Coulter blade	P-275	10" Share
D-128P	Lube fitting 5/16 str. dr. type		

Part No.	Description
10M1624P *	Carr. bolt 1/2-13 x 1-1/2
15M1216 *	Plow bolt 3/8-16 x 1
15M1416 *	Plow bolt 7/16 x 14 x 1
15M1638P *	Plow bolt 1/2-13 x 1-3/4
35M1200 *	Sq. nut 3/8-16
35M1400 *	Sq. nut 7/16-14
35M1600P *	Sq. nut 1/2-13

* Purchase common hardware locally