

120-

NOV 17 1987

OPERATOR'S MANUAL

LG 1001



ELECTRIC GARDEN TRACTOR

EGT 120 - EGT 150



For the Dealer and Operator
Read these instructions · Save it for reference



COLDWATER, OHIO 45828, U.S.A.

**AVCO NEW IDEA Farm Equipment Division,
AVCO Distributing Corporation
Lawn and Garden Warranty**

CUSTOMER WARRANTY

Tractors, Attachments & Accessories

Subject to the warranty terms and conditions set forth herein AVCO NEW IDEA Farm Equipment Division, AVCO Distributing Corporation warrants its lawn and garden products to be free from defects in material or workmanship for a period of (1) year in ordinary home use (3 months if in commercial or institutional use) following the date of sale to the original purchaser.

Power Pack (Batteries)

Subject to the warranty terms and conditions set forth herein AVCO NEW IDEA Farm Equipment Division, AVCO Distributing Corporation warrants that it will replace any individual garden tractor power pack unit with which this warranty is furnished if it fails because of defects in material or workmanship for:

12 Volt Power Pack --- 1 year full warranty and 2 year pro rata for ordinary home use (6 months in commercial or institutional use) following the date of sale to the original purchaser. After 1 year in home use, but within 36 months following the date of purchase a power pack will be replaced at a pro rata service charge equal to 1/36th of the list price for replacement unit multiplied by the number of months which have elapsed from the date of original purchase to the date of failure.

The charge for service labor during the first (1) year in ordinary home use (3 months if in commercial or institutional use) will be covered under warranty. Service labor after the first (1) year is the responsibility of the owner.

A replacement unit will carry the above (1) year warranty and thereafter will be considered to be installed on the same date as the other units in the power pack for pro rata adjustment.

6 Volt Power Pack --- 2 year full warranty and 3 year pro rata for ordinary home use (6 months in commercial or institutional use) following the date of sale to the original purchaser. After 2 years in home use, but within 60 months following the date of purchase, a power pack will be replaced at a pro rata service charge equal to 1/60th of the list price for replacement unit multiplied by the number of months which have elapsed from the date of original purchase to the date of failure.

Power Pack (Batteries) Cont.

The charge for service labor during the first (1) year in ordinary home use (3 months if in commercial or institutional use) will be covered under warranty. Service labor after the first (1) year is the responsibility of the owner.

A replacement unit will carry the above (2) year warranty and thereafter will be considered to be installed on the same date as the other units in the power pack for pro rata adjustment.

WARRANTY TERMS

Any parts that are proved, in the Company's judgment, to be defective during the above period will be repaired or replaced, free of charge and without charge for installation, at the place of business of an AVCO NEW IDEA Lawn and Garden Dealer. It is the purchaser's obligation to bring the product or parts to the Dealer's place of business. If this is not possible, it is the purchaser's obligation to reimburse the Dealer for travel time and travel expenses incurred in fulfilling this warranty.

The Dealer will properly set up and adjust the product at time of delivery. This warranty shall not entitle the purchaser to any further adjustments or normal maintenance services.

The warranty shall not apply to any Garden Tractor, Power Pack, accessories or attachments which have been repaired or altered in any way so as, in the Company's judgment, to affect its reliability, or which has been subject to misuse, negligence or accident, or attachments mounted on tractors which are not included in the Company's approved list, or repair parts which have not been approved by the Company for use in connection herewith.

THE ONLY REMEDY FOR ANY BREACH OF WARRANTY AND THE ONLY REMEDY FOR THE COMPANY'S LIABILITY OF ANY KIND, INCLUDING LIABILITY FOR NEGLIGENCE, WITH RESPECT TO ANY PRODUCT, SHALL BE LIMITED TO THE REPAIR OR REPLACEMENT OF ANY DEFECTIVE PARTS AS STATED ABOVE, AND SHALL IN NO EVENT INCLUDE ANY INCIDENTAL OR CONSEQUENTIAL DAMAGES.

THIS WARRANTY IS IN LIEU OF ANY OTHER WARRANTY, EITHER EXPRESSED OR IMPLIED.



**EGT 120 ELECTRIC TRACTOR
WITH 42" MID-MOUNT MOWER**



**EGT 150 ELECTRIC TRACTOR
WITH 42" MID-MOUNT MOWER**

The Electric Garden Tractor is the result of careful design engineering with features such as: safety, ease of operation, economy, ruggedness and maintenance-free features.

Electricity is the cleanest most dependable and economical source of power.

It is Very Important that Each Operator Fully Understand the Controls, Safety and Maintenance of their Garden Tractor. Read the Operator's Manual Carefully.

Index

Safety Practices	2
Specifications and Service Chart	5
Troubleshooting Check List	4
Operation and Adjustment	6 to 10
Lubrication, Service and Maintenance	16 to 19
Power Pack Servicing	12 to 15
Assembly Procedure	20 to 25
Storage	20
Mower - 42" set up and adjustment	22 to 27

SAFETY



BE ALERT!

SAFETY IS IN YOUR HANDS

SAFETY PRACTICES

As with all power devices, prime responsibility for safe operation of the equipment rests with the operator. It is necessary that both operating instructions and the following safety information be fully understood by each operator before using the tractor and attachments.

- Become familiar with the location and function of all controls.
- Be sure the work area is clear of objects such as stones, metal objects, or sticks, which might be picked up and thrown by the mower.
- Regulate travel speed according to ground conditions.
- Don't forget to set the brake and shut off attachment power before you leave the tractor.
- Don't drive too close to creeks or ditches, in order to avoid the chance of tipping.
- Watch out for traffic when near roadways.
- Vehicles and attachments should be stopped and inspected after striking a foreign object and any damage should be repaired before re-starting and operating the equipment.
- Mow up and down the face of slopes; never across the face.
- Stay alert for holes and other hidden hazards.
- Watch where you're driving! Pay attention! The tractor is heavy and very powerful.
- Beware of steep slopes! Reduce speed on all side slopes and sharp turns to prevent tipping or losing control.
- Don't attempt to operate tractor when not in seat.
- Don't carry passengers without proper provisions.
- Keep people and pets at a safe distance, especially in the direction of mower discharge.
- Don't wear loose-fitting clothing that might get caught in moving parts.
- Never attempt to get off the tractor while it is in motion.
- Don't stop or start suddenly when going uphill or downhill. A sudden change of speed could upset the balance of tractor or operator.
- Keep tractor in good operating condition. Maintain all safety devices as indicated in this manual.
- Plug tractor charger cord into a normal 115-volt 3-hole grounded receptacle. Do not use a 2-hole adapter unless properly grounded.
- Keep hands and feet clear of all rotating equipment.
- Disconnect power cord connections from tractor to attachment before handling or servicing power attachments.
- All safety devices are for your protection. Do not attempt to defeat them.
- Shut off power to attachments when transporting or not in use for safety and to conserve power.
- Take all possible precautions when leaving vehicle unattended; such as turning PTO switch to "Off", lowering attachments, setting parking brake, and removing key.
- Keep motors free of grease, leaves, or grass to prevent heat build-up.
- Use care when pulling loads or using heavy equipment.
 - Use only approved drawbar hitch points.
 - Limit loads to those you can safely control.
 - Do not turn sharply. Use care when backing.
- When using any attachments, never direct discharge of material toward bystanders or allow anyone near vehicle in operation.
- When using tractor with mower:
 - Mow only in daylight or in good artificial light.
 - Check blade mounting bolts for proper tightness at frequent intervals.
- Keep all guards in place on mower.

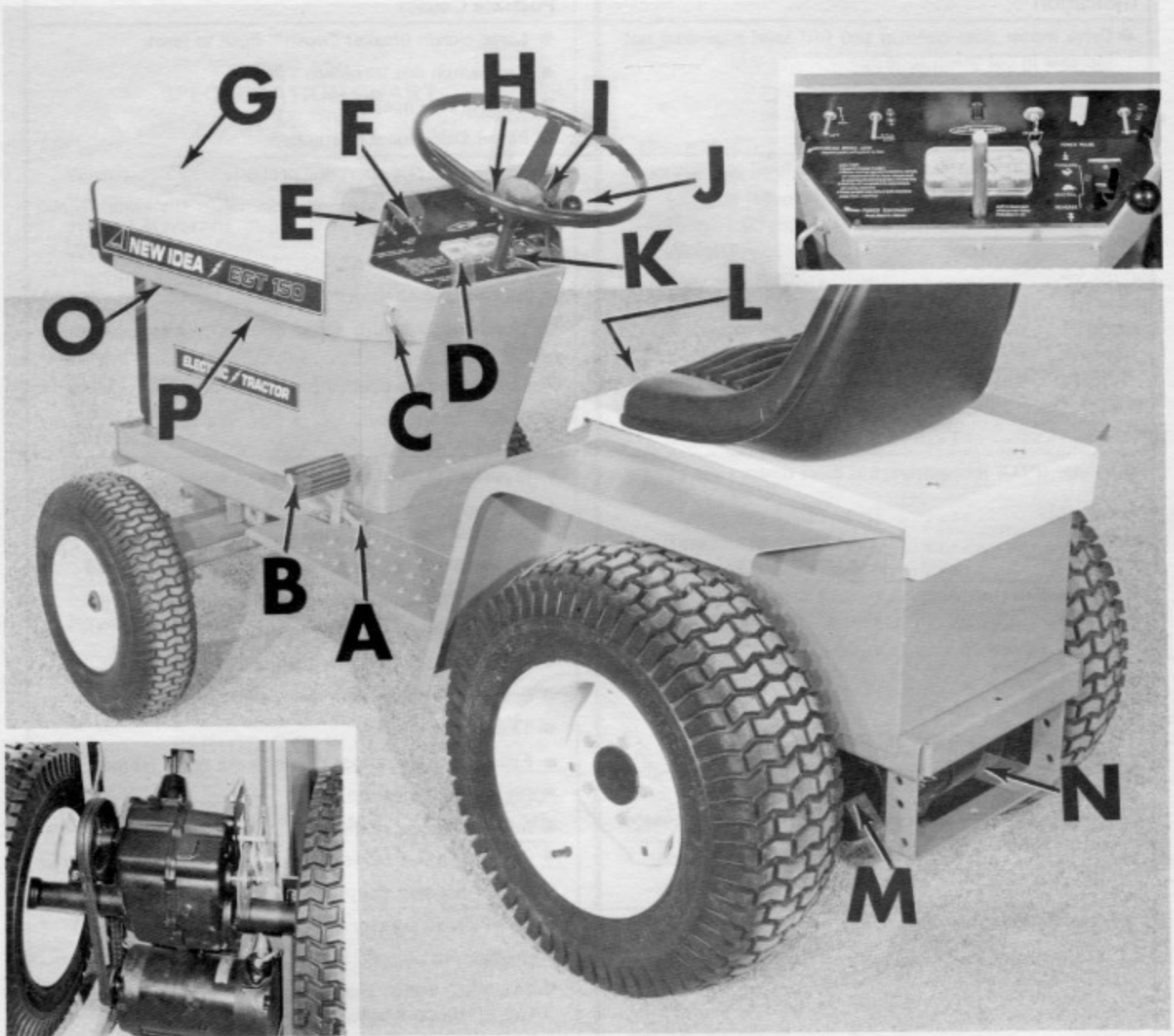

Figure 1

- FIG. 1 A. Parking Brake
 B. Brake Pedal
 C. Power Disconnect
 D. Fuel Level Gage
 E. Attachment lift switch
 F. P.T.O. Switch
 G. Charger

- H. Key Switch
 I. Light Switch
 J. Speed Control
 K. Power Use Gage
 L. Range selector
 M. Transaxle
 N. Electric Power Motor
 O. P.T.O. Outlet
 P. Accessory Outlet

TROUBLESHOOTING CHECK LIST

Indication	Possible Causes
<ul style="list-style-type: none"> ● Drive motor does not run and fuel level gage does not indicate in the green zone. 	<ul style="list-style-type: none"> ● Large circuit breaker "open". Push to reset. ● Key switch not turned to "On". ● Control fuse open. ● Power Disconnect disengaged.
<ul style="list-style-type: none"> ● Drive motor does not run, but fuel level gage indicates in green zone. 	<ul style="list-style-type: none"> ● Seat switch not operating properly. ● Clutch switch does not close when the clutch/brake pedal is depressed. ● Key switch not "On". ● Parking brake engaged. ● Momentarily return speed control to neutral, then re-start. ● Circuit Breaker opened (wait for automatic reset). ● Check connections on either brake or seat safety switches.
<ul style="list-style-type: none"> ● Mower (PTO) inoperative, but drive motor runs. 	<ul style="list-style-type: none"> ● Proper PTO starting sequence not followed. ● PTO switch not moved from "Start" to "Run" position after starting motors. ● Mower motor power cord connectors not joined.
<ul style="list-style-type: none"> ● Reduced tractor range. 	<ul style="list-style-type: none"> ● Charger not started at proper dial setting. ● Brake dragging. Readjust caliper unit. ● Drive belt slipping due to adjustment or wear. ● Power pack electrolyte level low. ● Tires underinflated. ● Failure to fully release clutch/brake pedal on long runs. ● Improper lubrication. ● Improper range selection. (Also lower range.) ● Blunted mower blades. ● Mower housing clogged.
<ul style="list-style-type: none"> ● Power Pack not charging. 	<ul style="list-style-type: none"> ● Small circuit breaker "open". Push to reset. ● Charger not plugged into 115-VAC outlet. ● 115-VAC outlet inoperative due to open household fuse or circuit breaker. ● Failure to start charger at proper dial setting. ● Power disconnect disengaged.
<ul style="list-style-type: none"> Lights inoperative. 	<ul style="list-style-type: none"> ● Light fuse open. ● Bulbs burned out.
<ul style="list-style-type: none"> Lift inoperative. 	<ul style="list-style-type: none"> ● Lift fuse open. ● Lift motor connections loose. ● Circuit breaker opened, wait briefly for automatic reset.
<ul style="list-style-type: none"> PTO equipment inoperative but other circuits operative. 	<ul style="list-style-type: none"> ● Sit on tractor seat, turn key switch to "On", turn PTO switch to "Off", then "On". ● Sit on tractor seat, turn key switch to "On", turn PTO switch to "On", then release. ● Check attachment plug-in.
<ul style="list-style-type: none"> Accessory tools inoperative. 	<ul style="list-style-type: none"> ● Power disconnect disengaged. ● Circuit breaker open. Reset manually. (See page 12.) ● Check tool plug-in for loose connection.

**EGT 120
SPECIFICATION CHART**

General

Width 35 inches
 Length (Overall) 69 inches
 Height (Overall) 42 inches
 Weight 800 lbs.
 Turning Radius (inside) 47 inches
 Frame Unitized
 Accessory Outlet (36 volt) Standard
 Brake Disc
 Front Tires 4.80 X 8
 Rear Tires 8.50 X 12
 Seat Bucket

Drive System

Power Pack 36 Volt Standard
 Transaxle 3 Speed
 Transaxle Oil Capacity 4 US Pints
 Speed Control Hand Control
 Power Pulse Switch Standard

PERIODIC SERVICE CHART

Service	Monthly	Every 100 Operating Hrs.
Check power pack water level	X	
Check tire pressures	X	
Check drive belt tension		X
Check transaxle oil level		X
Clean power pack top surfaces if necessary		X
Check fasteners and connectors for tightness		X
Grease wheels, spindles and steering assembly		X
Oil exposed moving parts — brake pedal, hinges, etc.		X

**EGT 150
SPECIFICATION CHART**

General

Width 36 inches
 Length (Overall) 69 inches
 Height (Overall) 42 inches
 Weight 835 lbs.
 Turning Radius (inside) 47 inches
 Frame Unitized
 Accessory Outlet (36 volt) Standard
 Brake Disc
 Front Tires 4.80 X 8
 Rear Tires 9.50 X 12
 Seat Bucket

Drive System

Power Pack (36 volt) Heavy-duty
 Transaxle 4 Speed
 Transaxle Oil Capacity 4 US Pints
 Speed Control Hand Operated
 Power Pulse Switch Standard

PERIODIC SERVICE CHART

Service	Monthly	Every 100 Operating Hrs.
Check power pack water level	X	
Check brake operation (adjust if necessary)	X	
Check tire pressures	X	
Check drive belt tension		X
Check transaxle oil level		X
Clean power pack top surfaces if necessary		X
Check fasteners and connectors for tightness		X
Grease wheels, spindles and steering assembly		X
Oil exposed moving parts — brake pedal, hinges, etc.		X

OPERATION AND ADJUSTMENTS

WARNING:

OPERATOR SHOULD NOT "FIREWALL" OR QUICKLY ADVANCE THE SPEED CONTROL IN STARTING FROM A STANDSTILL, ESPECIALLY IF STARTING UNDER LOAD. THIS PRACTICE DRAWS HIGH CURRENT THROUGH THE DRIVE MOTOR AND CAN ALSO RESULT IN A SUDDEN SNAP-START. THE ELECTRIC TRACTOR IS MUCH THE SAME AS AN AUTOMOBILE: IT IS A POWERFUL MACHINE WHICH MUST BE HANDLED WITH CARE AND JUDGEMENT. SPECIAL CARE IN STARTING AND BRAKING ON HILLY TERRAIN IS IMPERATIVE FOR SAFE OPERATION SINCE THE BALANCE SHIFTS TO MAKE THE MACHINE LESS STABLE AS THE ANGLE OF THE GROUND INCREASES. SUDDEN STARTS UPHILL OR STOPS WHEN ROLLING DOWN HILL, COULD UPSET STABILITY AND CAUSE POSSIBLE DAMAGE TO THE EQUIPMENT OR INJURY TO THE OPERATOR. IT SHOULD ALSO BE NOTED THAT THE TRACTOR WILL CLIMB A STEEPER HILL THAN IT CAN SAFELY DESCEND, DUE TO THE SHIFT OF WEIGHT BALANCE WHICH RESULTS IN MORE TRACTION UPHILL BUT MUCH LESS WHEEL GRIP GOING DOWNHILL. STARTING SHOULD BE DONE BY GRADUALLY ADVANCING THE SPEED CONTROL UNTIL THE FULL-FORWARD POSITION IS ATTAINED. THIS POSITION GIVES MAXIMUM TORQUE AND EFFICIENCY. SHIFTING TO A LOWER RANGE SELECTOR POSITION OR DEPRESSION OF THE POWER PULSE SWITCH MAY BE NECESSARY IF THE STARTING LOAD IS HIGH OR IF THE TRACTOR SLOWS AND THE POWER USE GAGE READS IN THE RED.

DASH CONTROL

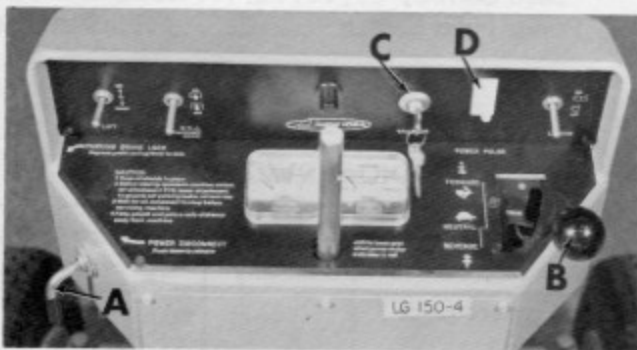

Figure 2

TO START

1. Operator must be seated in the seat.
2. Power Disconnect "A" must be engaged.
3. Move speed control "B" to "neutral".
4. Turn tractor key "C" to "ON".
5. Move range selector to desired position.
6. Release parking brake.
7. Move speed control slightly forward. Increase movement for higher forward speed.

TO STOP

Return speed control to neutral and/or depress brake pedal.

NOTE:

QUICK STOPS CAN BE MADE BY FULLY DEPRESSING THE BRAKE PEDAL WITHOUT RETURNING THE SPEED CONTROL TO NEUTRAL. FULL DEPRESSION OF BRAKE

PEDAL SWITCHES DRIVE POWER OFF FOR CIRCUIT PROTECTION.

BEFORE DRIVE POWER CAN BE RESTORED, THE SPEED CONTROL MUST BE RETURNED TO NEUTRAL AND THE BRAKE RELEASED. MOVEMENT OF THE SPEED CONTROL WILL THEN RESTORE OPERATION.

TO REVERSE

1. Stop tractor by returning speed control to neutral and/or depressing the brake.
2. Release brake.
3. Move speed control slightly to the rear. Higher reverse speed results from moving lever further to the rear.

NOTE:

NEW POWER PACKS HAVE A "BREAK-IN" PERIOD. IT IS RECOMMENDED THAT DEEP DISCHARGING BE AVOIDED FOR THE FIRST 5 OPERATIONAL PERIODS. THIS WILL ASSURE LONGER POWER PACK LIFE. DEEP DISCHARGING CAN BE IDENTIFIED WHEN THE FUEL LEVEL GAGE READS IN THE RED TO THE LEFT OF "E".

ATTACHMENTS

Operational information for the 42 inch rotary mower is found on pages 22 through 27 of the manual. Tractor attachments or accessories are found in the specific manual or instruction sheet supplied with that unit.

The rear pin hitch is provided for light hauling only. Heavy hauling, impact pulling, or operation of ground breaking implements requires the addition of the optional sleeve hitch.

OPERATION AND ADJUSTMENTS

NOTE:

UNDER NO CIRCUMSTANCES SHOULD AUTOMOTIVE ELECTRICAL EQUIPMENT SUCH AS LIGHTS, HORNS, OR ANY GROUNDED FRAME DEVICE BE ATTACHED TO THE ELECTRIC TRACTOR. THE TRACTOR FRAME IS NOT GROUNDED AND SUCH DEVICES COULD CAUSE DAMAGE TO THE CONTROL SYSTEM AND A POTENTIAL SAFETY HAZARD IF USED.

POWER PULSE SWITCH

For convenience, a power pulse switch "D", Fig. 2 is located on the control panel. This switch provides additional drive-motor torque for unusual starting situations which may occur. For example, while mowing, forward motion may be interrupted for maneuvering during an uphill climb. To regain forward speed, the speed control would normally be returned to "neutral" and then moved "fully forward"; but if this practice is followed with the range selector in D₁ or D₂, forward motion may not result unless the power pulse switch is momentarily depressed while the speed control is in the "full forward" position. This switching overrides protective circuitry and must only be used for starting during unusual situations. Wherever repeated use of the power pulse switch is required, a lower gear should be used with the range selector which will keep the protective circuitry inactive.

The starting of each run with a moldboard plow may also require the use of the power pulse switch, since high torque is required to get the earth turning started, and then a fairly swift forward speed is needed to sustain the earth-turning or rolling effect.

As is pointed out in each example, the power pulse switch is only depressed momentarily to obtain forward motion and is never held depressed for more than a second. It should also be noted that the same hill could be climbed without the use of the power pulse switch if the tractor were not stopped midway on the hill.

The power pulse switch is operable in forward only. When high loading prevents reverse operation, the range selector should be placed in a lower gear.

NOTE:

THE POWER PULSE SWITCH SHOULD ONLY BE USED AS SUGGESTED AND NO ATTEMPT SHOULD BE MADE TO ABUSE IT OR DEFEAT ITS PURPOSE OR EQUIPMENT DAMAGE MAY RESULT.

RANGE SELECTOR - EGT 120

Fig. 3 - Range selector lever position determines one of the three speed-torque ranges according to the pattern shown in Figure 2. The "L" position gives the highest torque and "D₂" gives the highest speed. See Table 1.

Range Selector Diagram

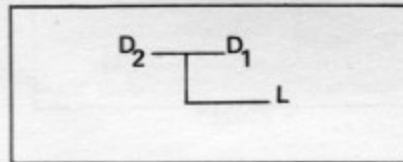

Figure 3.

Designation	Use
L - Low (Up to 2.5 mph)	Snowthrowing Hauling (Heavy Loads) Ground Engaging Attachments Snow Plowing
D ₁ - Drive One (Up to 4.0 mph)	Heavy Mowing Hauling (Medium Loads) Raking and Seeding Snow Plowing (Dozer Blade)
D ₂ - Drive Two (Up to 6 mph)	Transporting Snow Plowing High Speed Mowing Hauling (Light Loads)

Range selection is made with a quick, positive hand motion, **BUT ONLY AFTER DRIVE MOTOR ROTATION HAS STOPPED.**

NOTE:

WHEN RANGE SELECTOR GEARS DO NOT MESH IMMEDIATELY, A MOMENTARY APPLICATION OF DRIVE POWER WILL REPOSITION THE GEARS AND ALLOW SHIFTING. DO THIS BY MOVING THE SPEED CONTROL FORWARD, RETURN IT TO NEUTRAL, AND MOVE THE SHIFT LEVER. DO NOT FORCE GEAR CHANGES IF ANY INTERFERENCE IS INDICATED.

OPERATION AND ADJUSTMENTS

RANGE SELECTOR – EGT 150

Fig. 4 - Range selector lever position determines one of the four speed-torque ranges according to the pattern shown in Figure 2. The "LL" position is accessible by shifting through the "L" position.

Range Selector Diagram

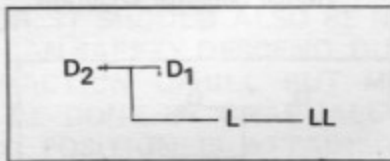

Figure 4.

Designation	Use
LL – Low-Low (Up to 0.8 mph)	Heavy Snowthrowing Tilling Ground Engaging Attachments
L – Low (Up to 2.6 mph)	Light Snowthrowing Hauling (Heavy Loads) Ground Engaging Attachments Gravel or Dirt Dozing
D1 – Drive One (Up to 4.5 mph)	Heavy Mowing Hauling (Medium Loads) Raking and Seeding Snow Plowing (Dozer Blade)
D2 – Drive Two (Up to 7.0 mph)	Transporting Snow Plowing High Speed Mowing Hauling (Light Loads)

Range Selection is made with a quick positive hand motion, **BUT ONLY AFTER DRIVE MOTOR ROTATION HAS STOPPED.**

NOTE:

WHEN THE RANGE SELECTOR GEARS DO NOT MOVE OR MESH EASILY, A MOMENTARY APPLICATION OF DRIVE POWER WILL REPOSITION GEARS AND ALLOW SHIFTING. DO THIS BY MOVING THE SPEED CONTROL FORWARD MOMENTARILY. DO NOT FORCE GEAR CHANGES IF ANY INTERFERENCE IS INDICATED. BE CAREFUL TO HAVE TRACTOR PATH CLEAR OF OBJECTS OR PEOPLE IN CASE MOVEMENT OCCURS DURING THIS OPERATION.

TRACTOR KEY SWITCH

Fig. 5 - The "OFF" position disconnects all tractor electrical circuits with the exception of the charger, lights, and accessory receptacle. These circuits are active with the key in either the "OFF" or "ON" position. The clockwise "ON" position allows power to be applied to the drive motor and PTO equipment.

SPEED CONTROL



Figure 5

Fig. 5 - Control of speed and of forward and reverse motion is made with one lever. Moving the speed control from "neutral" toward the front of the tractor increases forward speed. Moving the lever toward the rear from "neutral" increases reverse speed. (See Figure 5). The full-forward speed-control position provides maximum torque and highest efficiency after forward motion has started. (See the section on Power Pulse Switch).

LIGHTS

Fig. 5 - Operation of the tractor lights is independent of the key switch position, so that the lights can be used at night for lighting work areas or servicing front mounted attachments with the power safely turned off. In addition to lighting the dash panel, the dashlight serves as a reminder that the headlights are on. A rear tail light kit is available for safer night operation. Order Repair No. 120624.

OPERATION AND ADJUSTMENTS

LIFT CIRCUIT SWITCH

LIFT SWITCH

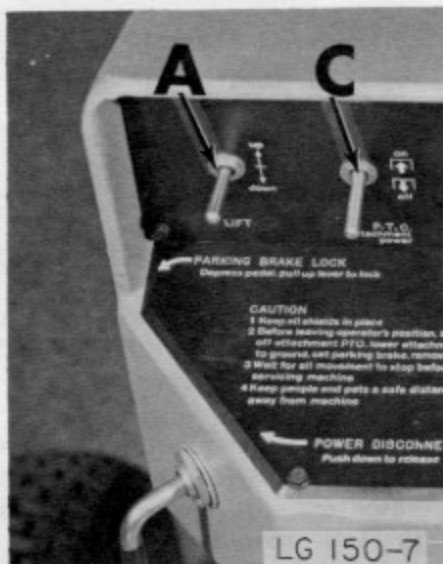

Figure 6

Fig. 6 & 7 - With an attachment properly mounted, the lift switch lever "A", Fig. 6 is held upward to raise the attachment, downward to lower it. Spring loading returns the switch to its center "OFF" position upon release. **Do not continue to power the lift after its raised limit has been reached.** Such abuse will trip the circuit breaker "B", Fig. 7 in the lift or will blow the protective fuse. To give attachments freedom to follow the ground contour, allow a small amount of slack in lift strap during operation by holding the lift switch down for about 1-2 seconds after the implement stops its downward movement.

FUEL LEVEL GAGE

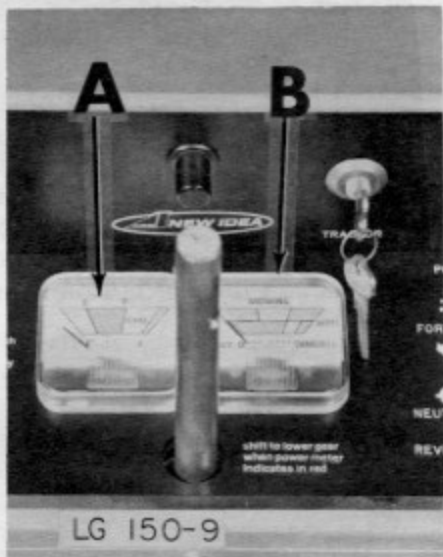

Figure 8

Fig. 8 - On the fuel level gage "A" the green zone between the "E" (empty) and "F" (full) represents range of the power pack. Readings in

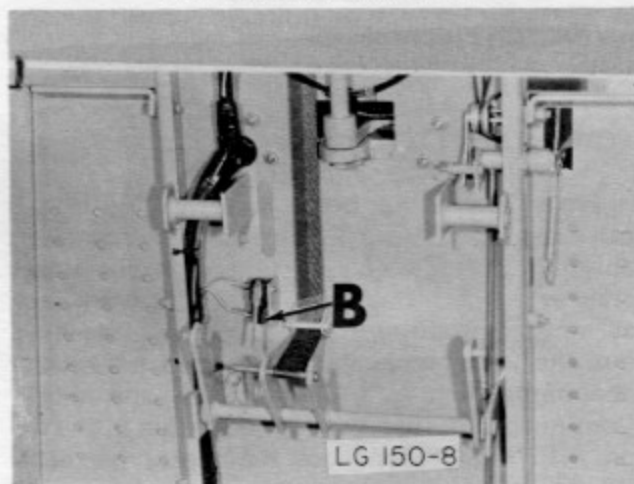

Figure 7

PTO (Power Take-off)

The dash-mounted PTO switch "C", Fig. 6 controls motorized attachments. Power is delivered through the PTO receptacle located just under the left edge of the hood toward the front of the tractor.

The PTO switch must be turned on after the key switch is turned to "ON". This is due to the safety interlock which prevents unintentional attachment start-up. If the driver leaves the seat with an attachment running, a safety interlock interrupts the attachment power. To restore attachment power, sit on seat and turn PTO switch to "OFF" and then to "ON".

this zone are fractional portions of full range remaining.

When the charger is in operation and nearing completion of its cycle, the "CHG" zone indicates the power pack is being fully charged. This assures you of proper charger operation. After the charging cycle is completed, the indication should be "F" or higher, to be interpreted as "full". Use of heavy work attachments or high loads on the tractor will cause the indicator needle to drop below "F" as the heavy drain period begins. The fuel level gage will always read lower during heavy power usage. When the gage consistently reads below empty, the load should be reduced until the indicator needle returns to the green area or the tractor is recharged enough to permit further operation.

While the right red zone represents "overcharge", the left one represents "overdischarge". If either of these zones are indicated after charging, check the trouble-shooting tips on page 4. If proper operation is not restored by the suggestions there, disengage the power disconnect and consult your dealer.

OPERATION AND ADJUSTMENTS

POWER USE GAGE

Proper use of the power use gage "B", Fig. 8 can extend the ELECTRIC tractor range considerably. Reference should be made to the upper scale when performing relatively light work such as mowing, transporting, hauling and sweeping, but the lower scale should be used for heavier operations such as snow throwing and tilling. Continued operation with an indication in the red on the "High" section of the appropriate scale should be avoided if possible. Prolonged operation with this indication will result in more rapid discharge of the power pack and is usually due to improper choice of speed-torque range or a jammed attachment. Whenever possible, the speed control lever should be maintained in the full forward position for most efficient operation.

During normal tractor operation, the power use gain indicator should remain in the green or lower yellow zone when proper gear selection has been made with the range selector. Heavy work such as snow removal and tilling may require operation in the red zone.

NOTE:
THE DRIVE MOTOR AND ITS CIRCUITRY ARE PROTECTED BY A CIRCUIT BREAKER. THIS AUTOMATIC SWITCH MAY OPEN AND SHUT OFF POWER UNDER EXTREMELY HEAVY LOADING. A FEW MINUTES WAIT IS USUALLY SUFFICIENT FOR THE CIRCUIT BREAKER TO AUTOMATICALLY RESET. IF THE CIRCUIT BREAKER CONTINUES TO TRIP, REDUCE THE LOAD BY SHIFTING TO A LOWER RANGE.

P.T.O. AND ACCESSORY OUTLET



Figure 9

PTO (Power Take-off)

Fig. 9 - The dash-mounted PTO switch "C", Fig. 6 controls motorized attachments. Power is delivered through the PTO receptacle "A", Fig. 9 located just under the left edge of the hood toward the front of the tractor.

The PTO operated equipment is turned on by preparing the tractor for normal operation (key on, operator seated). The PTO switch is then moved to "ON" momentarily and then released. Upon release, the switch automatically returns to its center "ON" position. To turn equipment off, move the PTO switch to the "OFF" position.

ACCESSORY RECEPTACLE

The accessory receptacle on the ELECTRIC tractor lets you take your power source to your work. A variety of 36-volt electric power tools, made just for the ELECTRIC tractor to make your home, yard, and garden chores easy and enjoyable are available from your dealer.

The accessory receptacle "B", Fig. 9 is located on the left side of the tractor under the edge of the hood to the rear of the PTO outlet.

When using a hand power tool, apply the parking brake and insert the accessory plug into the special receptacle rotating it slightly to the right to lock it in place. Voltage to this receptacle is always on regardless of key switch position. In the event that a power tool does not operate, be sure that the power disconnect is engaged and the manual reset circuit breaker button is pushed in.

NOTE:
THE 36-VOLT ACCESSORY RECEPTACLE IS DESIGNED TO PREVENT THE USE OF STANDARD 110-VOLT AC POWER TOOLS. USE ONLY APPROVED 36-VOLT TOOLS IN THE ACCESSORY RECEPTACLE.

BRAKE PEDAL AND PARKING BRAKE

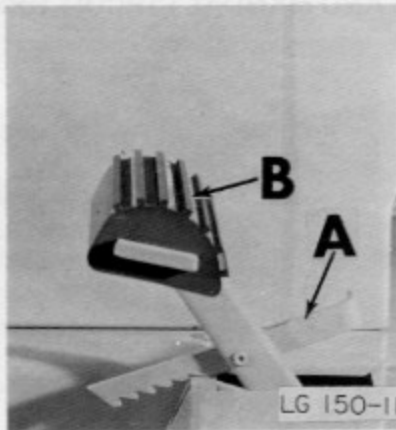

Figure 10

Fig. 10 - The ELECTRIC tractor is equipped with a disc-type brake fixed on the transaxle. This brake is used for normal stopping as well as a parking brake. To apply the parking brake "A", it is necessary to fully depress the brake pedal "B" and pick up on the rear of the parking brake lever until it engages the forward edge of the foot rest. When foot pressure is released, the brake pedal should remain in its depressed position. The parking brake is released by reapplying pressure on the brake pedal and moving the rear end of the parking brake lever downward to its stop.

BRAKE SWITCH

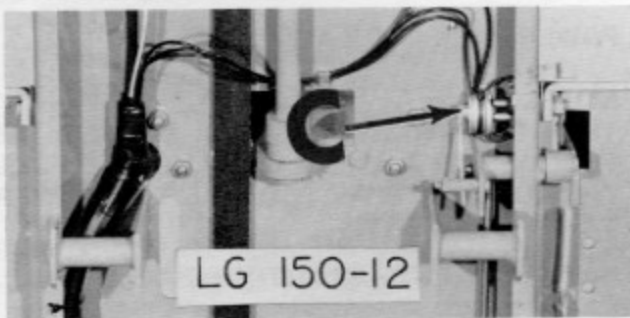

Figure 11

Fig. 11 - The brake pedal also activates a brake switch "C" which shuts off the drive motor circuit when the pedal is fully depressed. The tractor control is inoperative with the parking brake set. To restore drive-motor power, fully release the brake pedal and then start by returning the speed control to neutral and then moving it forward.

NOTE:
ALWAYS RELEASE THE BRAKE PEDAL FULLY BEFORE DRIVE POWER IS APPLIED.

SEAT SWITCH

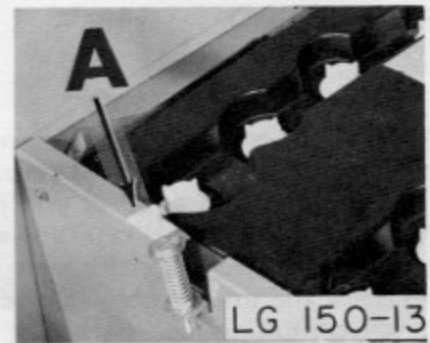

Figure 12

Fig. 12 - The seat must be occupied in order to close a switch "A" which permits power to be applied. If the seat is vacated for any reason, all power circuits are shut off.

BRAKE SWITCH

When the brake is applied fully, a switch "C", Fig. 11 interrupts power to the drive motor only. The PTO receptacle remains energized.

RETURN-TO-OFF

If power is interrupted to the PTO by the seat switch or turning off the key switch or power disconnect, it cannot be restored unless the PTO switch is turned off and then on again.

If power is interrupted to the drive motor, the speed control must be returned to "neutral" and then moved forward in order to start.

NOTE:

THESE INTERLOCKS ARE USED TO ENSURE MAXIMUM SAFETY FOR THE OPERATOR OF THE ELECTRIC TRACTOR. THEY SHOULD NEVER BE REMOVED FROM THE CIRCUITS, AND SHOULD BE KEPT IN GOOD WORKING ORDER.

ELECTRICAL PROTECTION
POWER DISCONNECT

Figure 13

OPERATION-ADJUSTMENT AND POWER PACK

POWER DISCONNECT

Fig. 13 - The power disconnect is an emergency device, which disconnects all electric power to the vehicle. It disengages power when you push the end of the lever downward. Should any electrical malfunction occur, disengage this unit immediately and check the troubleshooting check list on page 4 before consulting your dealer.

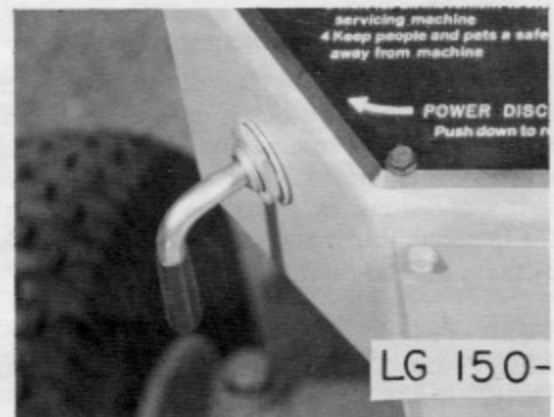
ALL SERVICING OF THE TRACTOR SHOULD BE DONE WITH THE "POWER DISCONNECT" DISENGAGED. (CHARGING REQUIRES THE POWER DISCONNECT TO BE ENGAGED).

The power disconnect is engaged by pushing the lever in before it is rotated upward. It is locked in this position by rotating counter-clockwise one-quarter turn.

CIRCUIT BREAKERS

Fig. 14 - Circuit breakers are used to protect the drive, lift, and charger circuits from damaging overloads. These devices operate on both high current and high temperature to sense potentially severe conditions that could damage the circuits or components, and they remove power to the circuits under such conditions. After a short interval of time, these breakers automatically reclose, and operation can be restored by following the normal starting procedure. Continued tripping is a signal to reduce the load, or to search for a fault such as jamming or maybe an electrical problem that requires dealer service. The automatic circuit breakers are located at, or within, the motors. (Manual reset circuit breakers are used on some of the attachments, while the automatic types are used for others. See the specific attachment manual for additional information.)

The circuit breaker "A" located on the control panel next to the fuse block is used to protect the charging circuit, as well as the accessory receptacle. This manual-reset breaker operates on over-current conditions in a similar manner to the motor breakers, but, when tripped, **must be reset by pushing the red reset button.**

NOTE:
POWER PACK CHARGING CANNOT OCCUR IF THIS MANUAL CIRCUIT BREAKER IS OPEN.

FUSES AND MANUAL CIRCUIT BREAKER



Figure 14

FUSES

Fig. 14 - The lift circuit is also protected by a 3AG30ASB fuse "B" located in the fuse block under the hood. If the lift motor fails to operate, check this fuse and replace it, if necessary, with one of identical specifications. The center fuse in the same block protects the tractor control and PTO circuitry. If this fuse fails, the drive motor and PTO operated attachments will not function. It should be replaced only with a 3AG20A fuse at "C". The third fuse in the block protects the light circuitry. This fuse should also be replaced with 3AG20A fuse, if necessary.

Order Repair Number:
30 Amp Fuse 120038
20 Amp Fuse 120039

POWER PACK CARE AND CHARGING

NOTE:

THE ELECTRIC TRACTOR SHOULD BE PLUGGED IN AND BROUGHT TO THE FULL CHARGE STATE AS SOON AS THE OWNER TAKES DELIVERY.

CHARGER STARTING SWITCH

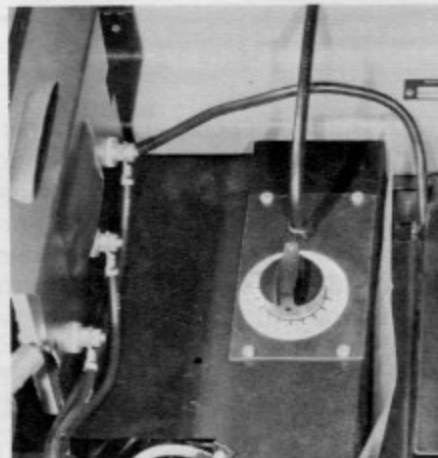

Figure 15

POWER PACK CARE AND CHARGING

The power pack is like a tank of energy. When using the tractor, this energy is drained. The charger replaces the used energy by properly converting and metering electricity into the power pack. The charger is designed to restore full charge to the power pack after one cycle of operation. Under normal conditions a full charge is nearly reached after 5 hours; however, the charger runs up to 19 hours to equalize cell voltages (when started on the "A" position. Older power packs require less charging time.) A full timed charge for cell equalization should take place at least once per week.

The charger runs independently of the key switch. It is suggested that the key be removed to prevent unauthorized use of the tractor.

CHARGER STARTING POSITIONS

(See Figure 16)

The amount of charging the power pack needs is dependent on:

1. Accumulative number of hours of operation since the last charge.
2. Temperature of tractor storage area.
3. Age of the batteries.

The charger dial starting positions A through J vary the charging period from very long at A to about half as long at J with numerous starting positions in between. The best indicator of the power pack's charging requirements is the amount of water to be added. If water must be added after one to three charges, the charger knob should be started at the next letter below that of the previous charge. The charger setting should not be varied more than one letter at a time, and two or more charges should be made before determining the need to use a new knob setting.

As the batteries age and go through more charging cycles, the charging period can be decreased.

As the temperature decreases, there is a need to **increase** the charge time. For example, a power pack discharge to the same level will require as

CHARGER STARTING POSITIONS

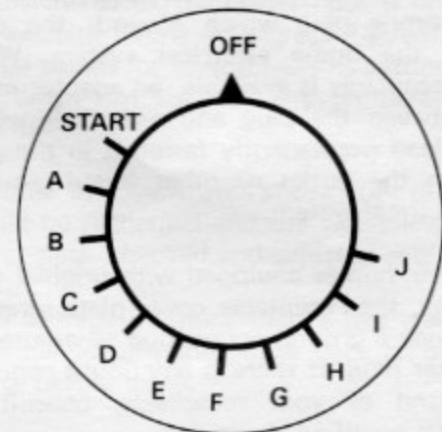

Figure 16

much as 50 percent more charge time for full recovery at 30°F than at 70°F. In very cold weather the "A" position can usually be used for all charging.

In any event, it is better to overcharge (charge too long) than to undercharge as long as there is not a high loss of water during charging. See "Power Pack Watering".

CHARGING

A **deeply discharged** power pack requires the charger to draw approximately 14 amperes from the 110-volt line receptacle. To prevent 15-ampere household fuses or circuit breakers from "opening" and interrupting power, it may be necessary to disconnect other appliances, tools, or lights from that circuit.

To start the charging operation, grasp both louvers at the rear of the hood and lift upward. Plug the charger cord into any 3-wire, grounded, 110-volt receptacle and turn the charger knob to the "Start" position determined by the age of the power pack (Figure 16). (New power packs go through a seasoning period and must be charged longer).

When the power pack is fully charged, the charger shuts off automatically. It is **not** necessary to remove the plug from the house receptacle after completion of the charging cycle. However, the tractor charger may be unplugged at any time during or after the charging cycle if the tractor is needed.

POWER PACK

The charger line cord is equipped with a standard 3-prong plug which grounds the charger through the home electrical system. When a 2-hole receptacle is available, an adapter must be used between the plug and receptacle with the ground lead permanently fastened to the ground screw on the outlet or other tested ground on your electrical system.

In older homes equipped with original electrical wiring, the receptacle cover plate screw may not provide a ground connection when used with an adapter plug. If there is any doubt concerning the ground of your receptacle, consult your dealer or a qualified electrician.

NOTE:
TO PREVENT OVERCHARGING, THE POWER PACK SHOULD NOT BE CHARGED IN AN AREA WHERE THE TEMPERATURE IS ABOVE 110° F.

POWER PACK WATERING

During the late stages of the charging cycle, there is a bubbling action or gassing process which allows some water in the electrolyte solution to evaporate. Remember that during this charging procedure **only water is lost**; so it is only necessary to **add water** to bring up the electrolyte level to the proper point. Distilled water or tap water that is low to average in mineral content is satisfactory for use in the power pack.

Water should be added only after the power pack is charged. The only exception to this rule is if the water level should fall below the top of the plates. Sufficient water should be added to bring the electrolyte level just above the plates. The system should then be charged, and if necessary additional water added **after** charging. (This is because the electrolyte expands during charging.)

NOTE:
POWER PACK ELECTROLYTE CAN CAUSE IRRITATION OF THE SKIN AND MAY DAM-

AGE CLOTHING. ANY CONTACTED ELECTROLYTE SHOULD BE IMMEDIATELY NEUTRALIZED WITH A SOLUTION OF BAKING SODA AND WATER, OR WASHED THOROUGHLY WITH SOAP AND WATER.

Any electrolyte running out of the top of the cells is an obvious sign of overfilling. It is important that the electrolyte level be maintained 1/4 to 3/8 inches above the plates but never above the indicator ring. Overfilling can result in dilution of electrolyte, which reduces capacity and life of the power pack. Overfilling can also cause corrosion where spillage of electrolyte occurs. (Your Avco New Idea Lawn and Garden tractor dealer has an automatic cell filler jug available at a low cost.)

Under normal conditions it only will be necessary to check the electrolyte approximately once per month. Use of the tractor in higher temperature locations or under very heavy use may require more frequent checks of the level. Also, after several years of use, it may be necessary to add water more often.

NOTE:
THE CHARGING PROCESS EVOLVES SMALL AMOUNTS OF HYDROGEN GAS; THEREFORE, NORMAL PRECAUTIONS LIKE THOSE FOR GASOLINE REFUELING SHOULD BE USED WHENEVER THE ELECTRIC TRACTOR IS BEING CHARGED. (NO SPARKS OR OPEN FLAMES NEAR THE TRACTOR.) THIS GAS CONCENTRATION WILL NOT OCCUR IF THERE IS FREE AIR CIRCULATION IN THE AREA WHERE THE TRACTOR IS STORED OR IF THE AREA IS LARGE SO THE CONCENTRATION IS REDUCED (I.E., A GARAGE).

COLD WEATHER POWER PACK CARE

The efficiency of a power pack is somewhat less at lower temperatures. In order to obtain optimum performance of your ELECTRIC tractor during the winter months, and to properly care for the power pack when not in use, the following recommendations should be followed:

TRACTOR IN STORAGE

1. Fully charge power pack by setting charger knob to indicator mark appropriate for age of power pack and letting charger operate until it shuts off.

NOTE:
ALWAYS BE SURE THAT THE DISCONNECT IS IN (ENGAGED) WHEN CHARGING.

2. Add water to each cell of the power pack to the specified level as described in the previous section. It is important for best power pack care to be sure (a) that the perforated plates which may be seen through the filling holes are covered by the electrolyte level to a depth of 1/4-3/8" before charging, and (b) that the level is brought to the bottom of the indicator ring after charging. In this way, overfilling is prevented but sufficient water is assured.
3. The tractor may be stored in the cold, provided the power pack is charged. Discharged power pack can freeze in cold temperatures unless recharged at once. The following table illustrates the relationship between amount of charge and freezing temperature of the electrolyte.

Amount of Charge	Freezing Temperature of Electrolyte
100%	-80F
75%	-42F
50%	-16F
25%	- 2F
10%	+ 7F

Self-discharge of the power pack is practically non-existent below 40-degrees Fahrenheit, and can be stored for several months without attention when not used in any temperature less than 40F.

4. If stored in a warm area above 40F, the tractor should be recharged and the water level in the power pack checked and adjusted about once a month.
5. After storage of more than a few weeks, it is advisable to give the power pack an overnight charge before using.

TRACTOR IN USE

1. Start the winter in good condition by following steps 1 and 2 as previously outlined under Tractor in Storage.
2. Whenever possible, give the power pack another charge before using if cold weather operation can be predicted. (The night of the snow storm if you plan to remove snow in the morning.)
3. Do not let the power pack stay discharged in cold weather. As soon as the work is completed, recharge the power pack. If idle time occurs between start and finish, plug charger into outlet and let the power pack charge while you are not using the equipment, even if for only a few minutes. (This is helpful in any weather to give maximum range and performance.)
4. There is little danger of overcharging the power pack when it is cold, so extra charging in the winter is advisable when the use is expected within the next 24 to 36 hours.

MAKE IT A HABIT!
REMOVE KEY PLUG IN START CHARGER

LUBRICATION AND MAINTENANCE

VISUAL INSPECTION

Periodic inspection of the tractor is an important preventive maintenance measure. Make it a habit to visually check for loose fastening devices or any evidence of abnormal operation. Inside storage or covering of the tractor will also give longer protection to the tractor.

Adjustments, inspections, and maintenance procedures on both the tractor and attachments should be performed at regular intervals to assure trouble-free, economical operation.

POWER PACK

In addition to power pack charging and watering as outlined, other services may be performed to give more desirable service.

Check the electrolyte level in the power pack monthly. Add water only if necessary. To protect your warranty, no addition of electrolyte should be done, except by your dealer.

City tap water or water of a low to average mineral content is acceptable for refilling. To prevent contamination of water, use the recommended water-filling jug or clean glass or plastic containers with a funnel.

It pays to keep the power pack covers clean. Removal of accumulations of dirt, grass clippings, and so forth will assure optimum electrical system performance. An occasional wiping with wet paper toweling is usually sufficient, or the power pack can be flushed off with water which will drain out at bottom of tractor.

NOTE:
FOR PERSONAL AND EQUIPMENT PROTECTION, ALWAYS UNPLUG CHARGER AND KEEP DRY WHEN CLEANING AND FLUSHING POWER PACK SURFACES.

ELECTRONIC CIRCUITRY

The bulk of the ELECTRIC tractor electronic circuitry is used for power control and switching and is located primarily in the control cabinet. Service in this area is to be made by your dealer only.

STEERING ASSEMBLY

The front axle and steering system of the ELECTRIC tractor are extremely rugged. Toe-in, and steering gear and linkage are carefully adjusted at the factory and should require no additional adjustments in normal service, barring improper operation. If any service becomes necessary, contact your dealer.

TIRES AND WHEELS

Proper tire inflation pressure is an important factor in determining tire life. Pressures should be checked and corrected, if necessary, on a monthly basis according to the following table.

Tire Inflation	Soil	Hard Surface
Front	10-15 psi (1)	15-28 psi(2)
Rear	8-10 psi	10-24 psi

Pressure measurement should be made with a low pressure gage which can be purchased from your dealer.

Use with chains requires the lowest pressures for smoothest ride and maximum traction.

Stumps, holes, and sharp objects should be avoided, and any cuts occurring in the tires should be repaired immediately or tire life will be reduced.

The rear wheels are factory-assembled in their narrow tread configuration. (See Figure 17). For greater safety when operating on hillside tread width may be increased by reversing the wheels on the hubs.

REAR TREAD CONFIGURATIONS

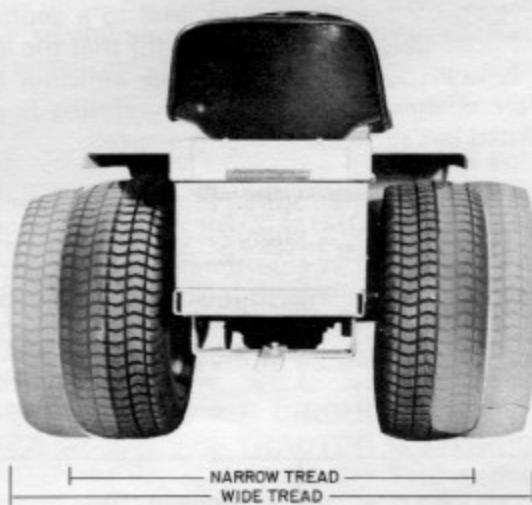

Figure 17

USE OF CHAINS

Chains on the rear tires will be found helpful on loose or soft surfaces, and particularly when using the snowthrower which, when lifted, counterbalances some of the weight off the rear wheels. When chains are used, locate the rear wheels on the hubs so that they are at the widest spacing. (The wheel rims can be bolted to the hubs with most of the width of the tire to the inside, under the fender; or can be flipped over with more of the width to the outside, leaving approximately 4 inches space between the tire

and the tractor frame.) This wide track also improves stability for snow removal service. If wheels are removed to obtain wide setting, assemble chains while wheel is off. If wheels are already set wide, chains may be assembled in normal manner with wheels left in place. Do not allow excess chain to rub or contact tractor body or frame.

FRONT WHEEL REMOVAL



Figure 18

Fig. 18 - Remove front wheels by removing snap ring, flatwasher at "A" and slide wheel off of axle. Reverse procedure to install front wheel.

REAR WHEEL REMOVAL



Figure 19

Fig. 19 - To remove the rear wheels, jack up the rear of the tractor and remove the 5 lug bolts holding wheel to wheel hub at "B". Reverse procedure to install rear wheels.

1. Lower pressure will soften the ride and improve traction.
2. The higher tire pressure will decrease rolling resistance and extend use range on paved or other hard surfaces. (This does not apply to use with chains on hard surfaces..)

LUBRICATION AND MAINTENANCE

BRAKE SWITCH ADJUSTMENT



Figure 20

BRAKE SWITCH

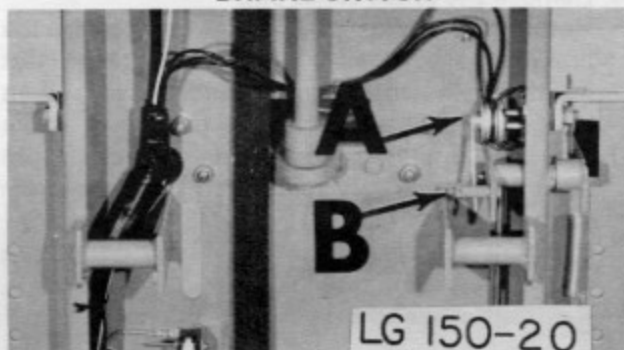

Figure 21

Fig. 20 & 21 - Proper brake switch adjustment causes the drive motor to shut off when the brake is depressed to 1/4 inch from its bottom stop. (See Figure 20.)

If adjustment is necessary, locate the brake switch "A" mounted on the underside of the frame immediately to the right of the brake pedal. Notice that the switch is actuated when its lever arm is deflected as the brake pedal is depressed. During this actuation, the lever arm rides on a shoulder bolt "B" mounted on a slotted pawl. It is this bolt that must be repositioned in the slot to adjust the drive motor/brake cut off point. After adjustment is made, check the cut off point and readjust if necessary.

BRAKE DISC ADJUSTMENT

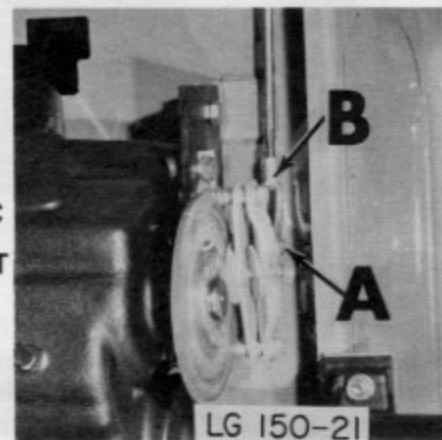

Figure 22

LUBRICATION AND MAINTENANCE

BRAKE AND PARKING BRAKE

Fig. 22 - A fully depressed brake pedal or an engaged parking brake should prevent the tractor from rolling on average inclines. If the brake does not perform satisfactorily, the following adjustment may be made:

1. Block the front wheels and move the range selector to neutral.
2. Remove the rear wheel on the brake side of the transaxle.
3. Remove the cotter pin from the brake clevis pin "A"
4. Remove the brake clevis pin.
5. Rotate the brake clevis "B" to shorten the brake linkage. Shorten till the brake drags (test by manually rotating the brake disk), then back off one-half turn at a time until brake drag is eliminated. The clevis and clevis pin must be temporarily reinstalled to check brake drag.
6. Reinstall the clevis, clevis pin, and cotter pin on the brake actuating lever.
7. Reinstall wheel and test brake function.

BELT ADJUSTMENT

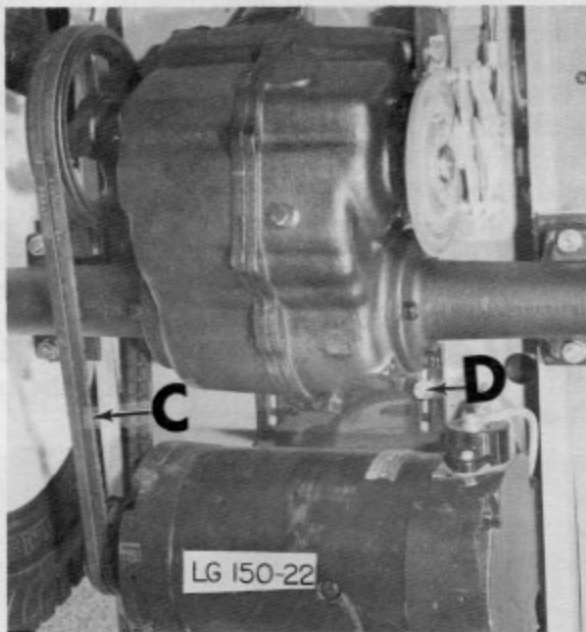

Figure 23

DRIVE ASSEMBLY

Fig. 23 - Power is transmitted from the drive motor to the transaxle through a heavy-duty, direct-coupled belt at "C". The belt should be kept free of grease, oil, electrolyte, and dressings and checked occasionally for tightness to assure best performance.

If the belt becomes contaminated it should be wiped with a clean cloth. Any belt slippage is due to moisture or loose adjustment. If the belt becomes wet and slips, temporarily select a lower speed range (higher torque) until the belt dries, and then resume normal operation.

BELT ADJUSTMENT

Fig. 23 - With the belt properly adjusted, a 10-pound force will deflect the belt approximately 1/4 inch.

If increased tension is required, proceed as follows:

1. Loosen four carriage bolts "D" holding motor plate. Insert a 1/4" wedge under the rear part of the motor plate, and retighten bolts finger tight.
2. With belt in place, force motor and mounting plate toward rear as far as possible. Tighten rear two carriage bolts.
3. Remove the 1/4" wedge, and tighten the front two bolts.
4. Recheck belt tension as outlined.
5. Recheck and tighten all bolts.

ELECTRIC LIFT

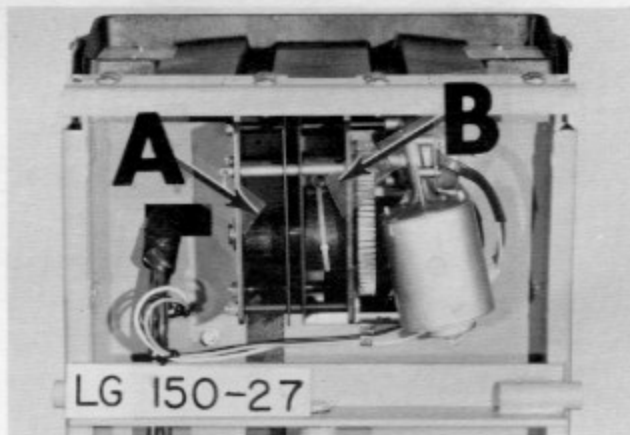
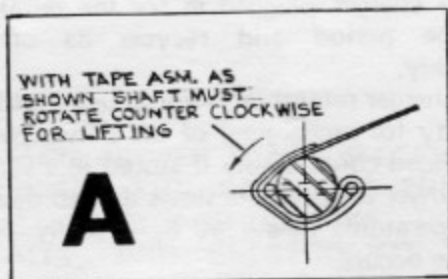

Figure 24

Fig. 24 - The electric lift can be used for either mid-mount or front mount attachment. For mid-mount attachment, use belt "A". For front mount attachment use belt "B".

For proper wrapping rotation of these belts, see Fig. 24A and 24B. Whichever belt is not being used, it must be wrapped for proper operation of the belt being used.



24A



24B

AFTER EACH 100 OPERATING HOURS OR EVERY 6 MONTHS

Fig. 25 - After 100 operating hours, the transaxle filler plug "A" should be removed and the fluid level checked. The oil level should be to the bottom edge of the filler hole "A". If necessary, replenish with approved axle fluid only, SAE-EP90.

If oil becomes excessively dirty, remove drain plug "B" and drain out oil and replace with new oil SAE-EP90.

TRANSAXLE

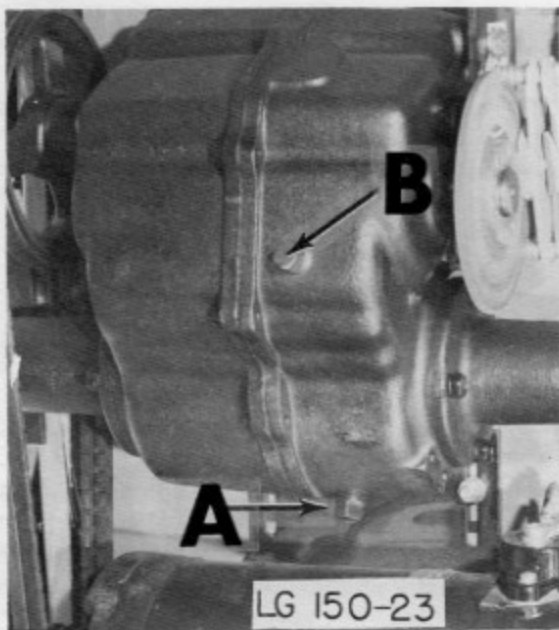

Figure 25

GREASING

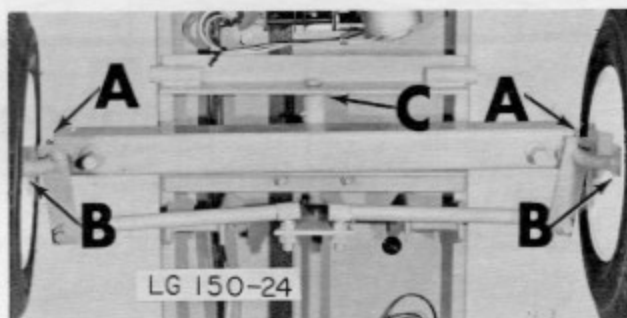

Figure 26

Fig. 26 - Twice a year or every 100 operating hours the following should be greased:

- A. Spindles
- B. Wheel bearings
- C. Pivot pins

Use a No. 2 multipurpose lithuim grease. Wipe off all excessive grease. Oil the following points with heavy duty No. 30 machine oil:

1. Brake pedal shaft and linkage connections.
2. Hood and seat hinges.
3. Attachment mounting pins.
4. Lift assembly pivot pins.

Prevent dirt and dust accumulation, by wiping away all excess oil.

These lubrication intervals are meant to be a guide only. If the tractor is subjected to abnormal environmental conditions or greater-than-average use, the frequency of lubrication as well as other preventive maintenance measures should be adjusted accordingly.

STORAGE AND ASSEMBLY PROCEDURE

STORAGE

Your tractor should be covered or under a roof in outside storage in snowy or rainy weather to give better protection and maintain performance and life of the equipment. Storage covers are available from your dealer which are custom tailored for your tractor.

Seasonal storage requires a minimum of preparation. The steps to be performed are as follows:

1. Wherever possible, store tractor in a cool, dry weather protected area or cover with the storage cover.
2. Clean power pack covers if necessary as outlined on page 16.
3. Plug charger into approved receptacle and start charger operation. Insure proper water level after first day (24 hours). (See page 16).

4. Lubricate tractor and wipe oil on any parts that may be affected by rust.
5. Leave charger plugged in for the duration of storage period and recycle its operation monthly.

The charger retention (without using additional electricity for recharging) of the power pack can be extended considerably if stored in a very cool place. Lower temperature slows the self-discharge. At temperatures below 40°F, virtually no self-discharge occurs.

NOTE:

AT TEMPERATURES BELOW 32°F THE FULL CHARGE STATE MUST BE MAINTAINED TO PREVENT CELL ELECTROLYTE FROM FREEZING WHICH MAY RESULT IN PERMANENT DAMAGE TO POWER PACK.

ASSEMBLY PROCEDURE

SEAT



Figure 27

Fig. 27 - Holes at spacing "A" in seat mounting are for your convenience. Position seat as desired and secure using four (4) 5/16 x 1" machine bolts and flatwashers.

STEERING WHEEL



Figure 28

Fig. 28 - 1. Place washer and plastic sleeve over the upper end of the steering shaft with its slotted end upward and aligned with the holes in the steering shaft.

2. Place the steering wheel on the shaft.
3. Align holes in steering post, sleeve and steering wheel.
4. Drive the spring dowel pin "A" into hole.
5. Snap the monogram cap into the center of steering wheel.

BATTERY INSTALLATION EGT 120 AND EGT 150

NOTE:

TO INSURE PROPER TRACTOR OPERATION, CHECK ALL THE BATTERIES PRIOR TO INSTALLATION FOR CRACKS, DEFECTS, POLARITY, AND ELECTROLYTE LEVEL. AVOID TOUCHING TOOLS OR CABLES TO THE TRACTOR FRAME WHILE INSTALLING AND HOOKING UP THE BATTERIES.

FORWARD COMPARTMENT

Fig. 29 & 30 - 1. Remove all loose parts from the forward battery compartment. Disengage the power disconnect.

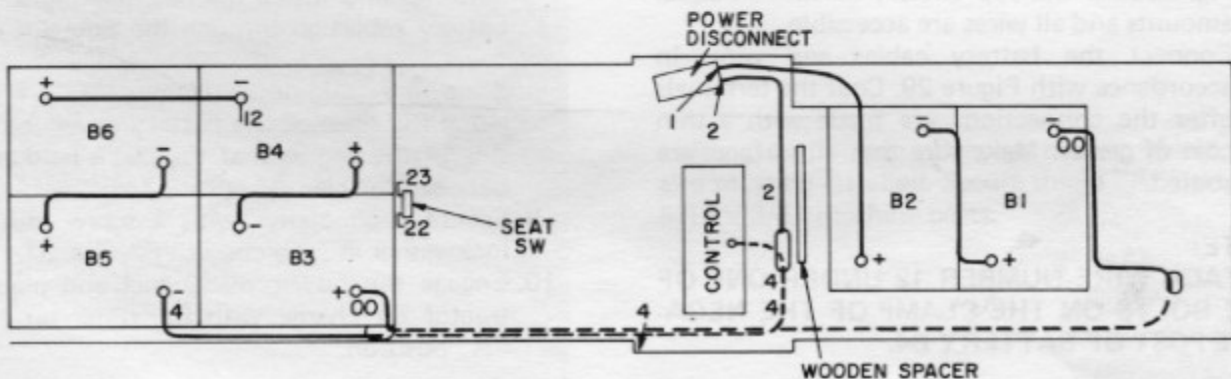

Figure 29

2. Place the plastic tray in the bottom of the forward battery compartment so that the drain hole lines up with the drain hole in the frame.
3. Unfold the smaller poly bag and place it in the tray so the bag's bottom seam runs from front to rear: Flatten the pockets that form at the seam ends so the bottom of the bag conforms to the tray.
4. Carefully set the batteries in the bag as shown in Figure 29 so that the sides of the bag remain above the top battery surface in equal amounts.
5. Insert the black wooden spacer between the bag and the front side of the control panel.
6. Connect the battery cables in accordance with Figure 29. Coat the terminals **after** connections are made with a thin coat of grease. Make sure that all surfaces are coated.
7. Place the plastic cover "A" over the batteries and **inside** the bag, making sure the battery cables go through the end slots of the cover.
8. Place the hold-down clamps "B" along the sides of battery cover but outside of the bag so the bag is held captive **between** the clamps and the cover.
9. Place the "U-shaped" bracket over the batteries so that each end engages the right angle piece on each hold-down clamp.
10. Slide the flat metal brace "C" through the slots in the side panels until its center hole lines up with the threaded hole in the "U" bracket.
11. Screw the thumb screw into threaded hole finger tight.

FRONT BATTERY COVER

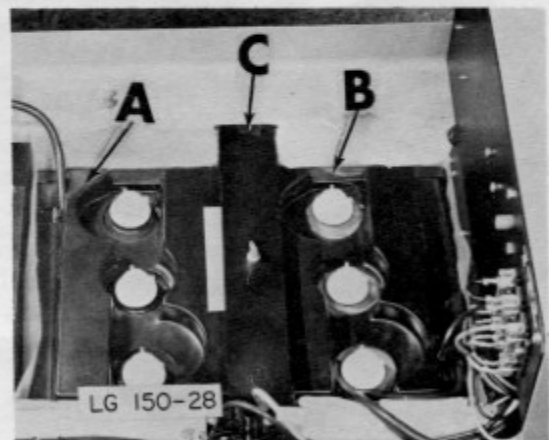

Figure 30

ASSEMBLY PROCEDURE

REAR COMPARTMENT

- Fig. 29 & 31 - 1. Remove all the loose parts from the rear battery compartment.
2. Connect the seat switch wires (numbers 22 and 23).
 3. Place the plastic tray in the rear battery compartment so that the drain hole lines up with the drain hole in the frame.
 4. Unfold the large poly bag and place it in the tray so the bag's bottom seam runs from front to rear. Flatten the pockets that form at the seam ends so the bottom of the bag conforms to the tray.
 5. Carefully set the batteries in the bag as shown in Figure 29 so that the sides of the bag remain above the top battery surface in equal amounts and all wires are accessible.
 6. Connect the battery cables and wires in accordance with Figure 29. Coat the terminals **after** the connections are made with a thin coat of grease. Make sure that all surfaces are coated.

NOTE:

ATTACH WIRE NUMBER 12 UNDER ONE OF THE BOLTS ON THE CLAMP OF THE NEGATIVE POST OF BATTERY B4.

REAR BATTERY COVER

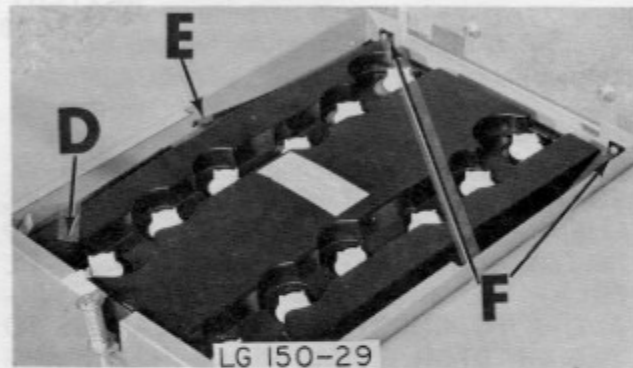

Figure 31

7. Place the plastic cover "D", Fig. 31 over the batteries and **inside** the bag, making sure the battery cables go through the side slot of the cover.
8. Place the hold-down clamps "E", Fig. 31 along the sides of the battery cover, but outside of the bag so that the bag is held captive **between** the clamps and the cover.
9. Secure each clamp with a screw, nut, and lockwasher at each end at "F", Fig. 31.
10. Engage the power disconnect and place the tractor on charge with the timer set to the "A" position.

MOWER ASSEMBLY TOP DECK - 42" SIDE OR REAR DISCHARGE

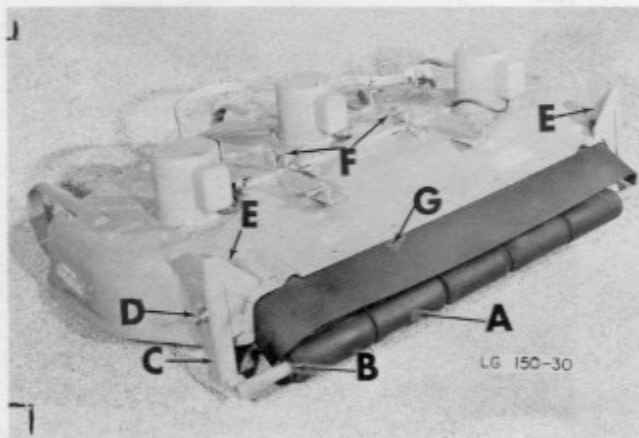

Figure 32

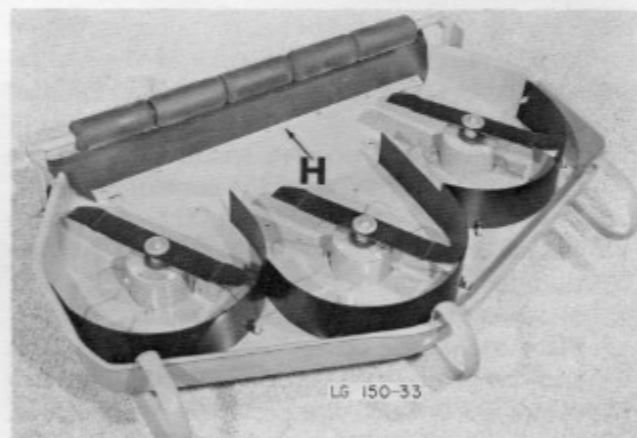

Figure 33

Fig. 32 & 33 - 1. Assemble the rollers "A" with a flat washer "B" between each roller onto shaft and insert the ends of the shaft into adjusters "C".

2. Attach the adjusters "C" to the mower-deck rear corners and secure each in the third lowest guide pinhole with a thumbscrew "D". Thread a locknut on each thumbscrew until the nut is flush with end of screw at "E".

3. Attach the end links "F" of the 3-link chains to the lifting bracket pins. Secure chain to pins with flatwasher and cotter pin.

4. Install discharge flap (rear discharge unit only) so flap is sandwiched between reinforcement strip "H" (Fig. 33) and underneath side of top deck. Secure in to place using (7) machine screws as shown.

SIDE DISCHARGE SHIELD

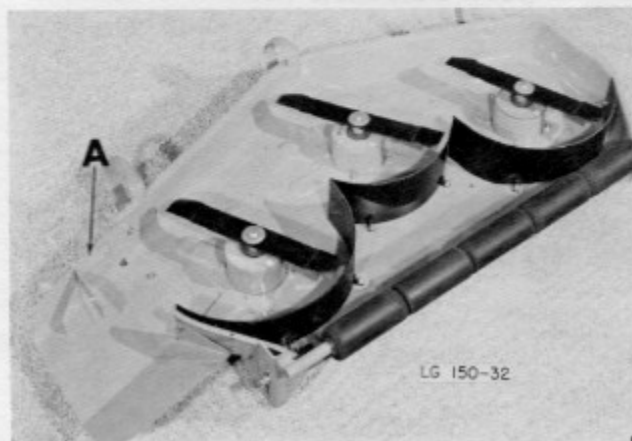

Figure 34

Fig. 34 - On side discharge mower, shield "A" also must be installed. Secure shield "A" using (4) 5/16 x 3/4" machine bolts.

NOTE:

ALSO AVAILABLE THROUGH REPAIR ARE TWO CONVERSION KITS FOR THE 42" MOWER.

1. Rear Discharge Kit, part number 120621 is recommended for the owner who mows his lawn frequently or intends to use a lawn sweeper. There is a greater degree of safety since the discharge is under and behind the tractor.

2. Side Discharge Kit, part number 120622 is recommended for the owner who mows his lawn less frequently without picking up his clippings. The side discharge produces greater vacuum action on long grass and disperses the clippings over a larger area.

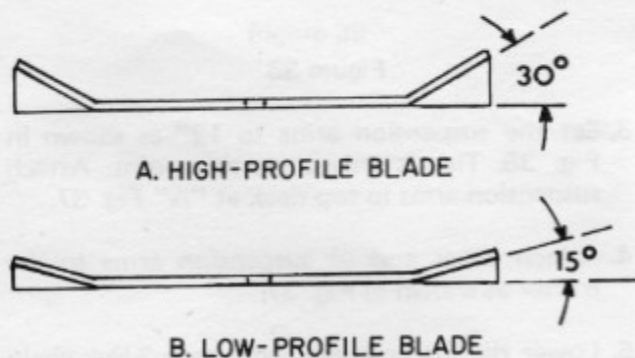

Figure 35

Fig. 35 - There are two types of blades available for mowing, a high-profile and low-profile, see Fig. 35. The high-profile blade use on side discharge mowers, gives a high discharge velocity, and the low-profile blade used on rear discharge mowers, gives extended mowing range with lower discharge velocity. Install in sets only.

ASSEMBLY PROCEDURE

KNIFE INSTALLATION

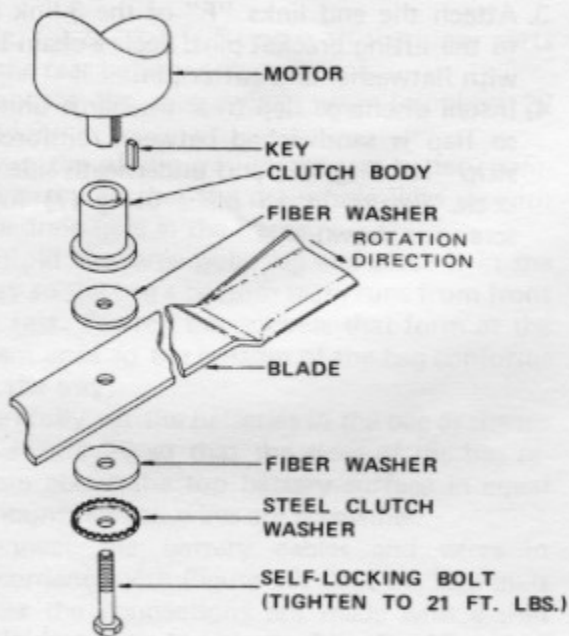

Figure 36

Fig. 36 - For installation or replacement of new blades always check that the cutting edge is in the proper direction for rotation. Install blades as shown in Fig. 36. Tighten each self-locking cap screw to approximately 21 foot pounds of torque. Make sure the square key stays in place when installing each clutch hub.

MOWER ATTACHING POINTS

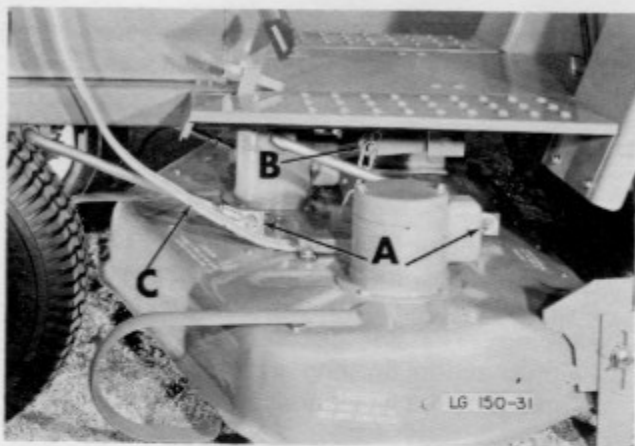

Figure 37

Figs. 37 & 38 - Attach the mower to tractor in the following manner:

1. Drive the tractor to a level area and disengage the Power Disconnect.
2. Center the mower under the tractor so the mower roller is adjacent to the tractor rear wheels.

SUSPENSION ARM

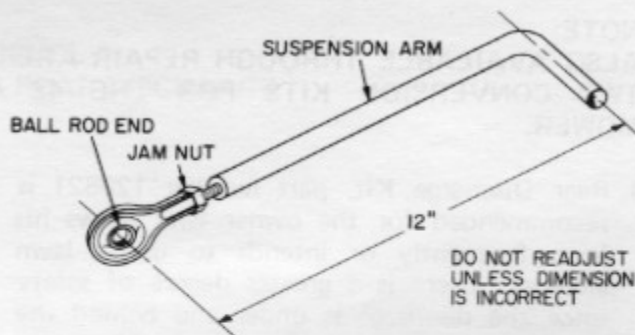

Figure 38

3. Set the suspension arms to 12" as shown in Fig. 38. This is only a starting point. Attach suspension arms to top deck at "A" Fig. 37.
4. Attach other end of suspension arms to the tractor as shown in Fig. 37.
5. Lower the lift brackets and attach 3-link chain "B" using washers and pin clips.

6. Lower the mower, stand clear of the mower housing and plug the P.T.O. cord "C" into P.T.O. receptacle.
7. Adjust tire pressure as indicated on Page 16.
8. Check levelness of mower. If not level readjust the suspension arms "A", Fig. 37 to obtain levelness of mower. If suspension arms are readjusted make sure jam nut is locked tight.
9. To keep the power cord clear of the front wheel, clip the hanger wire on the power cord five-inches from the plug, so the hooked end of the hanger wire can hang on the top edge of left side panel.
Removal of the mower follows the same steps in the reverse order.
After removal of the mower, carefully store the washers, hair pin cotters, and suspension arms, in the location from which they are removed for safekeeping.

WARNING:
ALWAYS DISCONNECT THE POWER CORD FROM THE PTO RECEPTACLE BEFORE HANDLING THE MOWER FOR ANY REASON.

ROLLER ADJUSTMENT

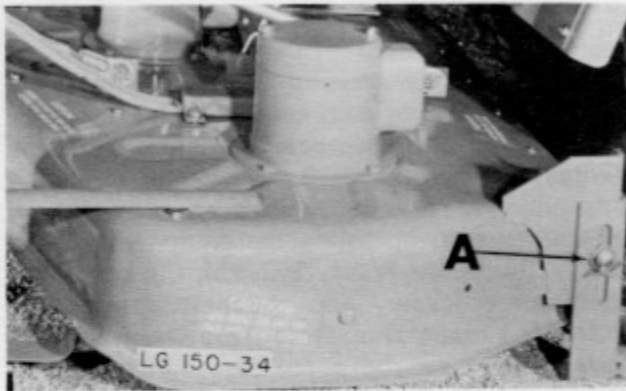

Figure 39

Fig. 39 - The rear mower roller is the only part that requires adjustment. Make adjustment as follows:

1. Remove the power cord from the PTO receptacle.
2. Raise the mower to the upper-most position.
3. Loosen the wing bolt (A) so the adjuster-bracket guide-pin is free of its locking hole.
4. Move the adjuster assembly to the desired position and locate the guide-pin in the corresponding locking hole. Moving the roller up gives a shorter cut.
5. Retighten the wing bolt.
6. Repeat the adjustment for the other side.

MOWER OPERATION

The operator must be seated on the tractor and the key switch turned to "On", before the PTO switch can be turned "On" to operate the mower. An electrical interlock prevents mower starting if this procedure is not followed. Once the mower is running, if the operator leaves the seat or turns the key switch to "Off", another interlock operates which not only interrupts mower power, but also stops blade rotation immediately by a dynamic braking action. To restart, with the key on, simply flip the PTO switch Off and On again. For all normal use, the PTO switch should be used to turn the mower on and off.

The maximum drive motor torque and most efficient use of power occurs when the speed control lever is at 3rd speed forward.

The D 1 range is best for average to heavy mowing, and D 2 range may be used for light duty, faster mowing. The Low (L) range should be used on steep hillsides for greater control.

When mowing on steep hillsides, the travel should be up and down. Care should be exercised to avoid sudden starts and stops, which may cause loss of control. The tractor motor will offer some braking action provided the speed control is **not returned to neutral**. Maximum retarding effect is obtained with the speed control in the full-forward position. Whenever operation on hillsides is required, the rear tractor wheels should be assembled in the "wide-tread" position for increased stability.

CUTTING

Always mow with sharp blades. The blades should be sharpened and balanced seasonally if subjected to average use, or whenever cutting quality deteriorates. Always disconnect the power cord before servicing or adjusting the mower. After each sharpening, if mower vibration is noticeable, the blades should be checked for balance. Unbalanced blades will shorten the life of the mower motor bearings.

For good appearance of the mowed lawn, it is very important to have the mower adjusted correctly for height of cut.

The best height-of-cut should be determined by locating the adjusters of the rear mower roller in the third-lowest guide-pin hole for the first few passes. If the grass is not cut short enough, use of the fourth-lowest hole will give a 1/2-inch shorter cut, and so forth. **Care must be used not to scalp uneven parts of the lawn by cutting too close.** As the cutting height is increased, some types of grass and turf may begin to show the front wheel

tracks where the grass is long enough to be rolled down and not spring back up. The roller assembly can be adjusted to give cuts 1-1/2 to 4-inches in 1/2-inch increments.

Experience in operating the equipment under various conditions is very important in obtaining maximum efficiency and the best appearance. After a few hours of operation, mower motor and blade loading can be easily determined by the sound and vibration produced. If the turf is very soft or the grass is very heavy the blade noise and mower vibration may increase signaling the operator of overloading. In this case, it is suggested that the mower be raised.

After mowing with the mower in this position, if it is desired to cut the grass shorter, another pass with the mower fully-lowered should be made. If the grass is not too long shifting into a lower range selector position may eliminate the need for raising the mower.

On average lawns that have merley grown too long it may be necessary to mow on two passes in the same manner as described above to prevent clogging of the chute. This would also be the method used to mow very high grass or weeds, but the initial pass should be made with the mower in its highest cutting position.

GROUND SPEED

Average to heavy mowing should be done in the D1 range. Light mowing may be done in the D2 range. If the cut is not even and clean, a lower range selector position should be used.

Level positioning of the mower is very important for good cutting quality and lower power consumption. If a mower motor becomes overloaded due to mowing too fast in high grass, too low or uneven adjustment for grass height, obstructions, clogging, or jamming, that motor may shut off momentarily. This is caused by the opening of a circuit breaker which prevents motor damage. After a short interval for cooling, the circuit breaker will reset automatically and the motor will restart. If the automatic circuit

When section of rough terrain or an area which may contain small stones is encountered, the operator should constantly adjust the lift to the conditions to prevent damage to the equipment or injury to the operator or bystanders.

If the tractor appears to groove the lawn or gives a bumpy ride, check the tire pressure. The pressure should be 8-10 psi rear, and 10-15 front.

breakers on the mower motors continue to interrupt operation of one or more motors after loading has been reduced, remove the power cord from the PTO receptacle and carefully check the mower adjustment on a level surface. If the mower is level and the cutting height correct, check the blades for obstructions.

WARNING:

MOWER MOTORS HAVE AUTOMATIC RE-CLOSING CIRCUIT BREAKERS. DO NOT HANDLE MOWER WITH TRACTOR SEAT OCCUPIED AND POWER ON. ALWAYS DISCONNECT POWER CORD BEFORE HANDLING MOWER.

MOWER OPERATING AND MAINTENANCE TIPS

- It is recommended that the underside of the mower deck be cleaned frequently to maintain maximum mowing effectiveness and reduce the likelihood of blade clogging. The mower must be removed to facilitate effective cleaning.
- Mowing of high grass may be made by making two passes; the first pass with the mower in its highest position. If there are low obstructions such as twigs or small stones in the mowing area, the second pass should be made with the mower still at a high setting to accommodate the obstructions.
- The mower must be removed when using tire chains to give adequate clearance.
- Sharpen and balance blades as required, but at least seasonally.
- Oil mower wheel axles, and lift pivot points frequently as needed with a 30 weight machine oil as indicated in the "Lubrication" section of this manual.
- On side discharge mower only, turn to the left as much as possible so that grass clippings will be discharged evenly to the right over grass already cut. Turning to the right causes a build up of grass clippings which prevents uniform cutting and causes an unnecessary load on the mower.

- On side discharge mower only, turn to the right when beginning to mow large open areas to discharge clippings away from borders such as sidewalks, fences, driveways, etc. After making two or three passes this way, mow in the opposite direction turning to the left to finish. See Figure 40.

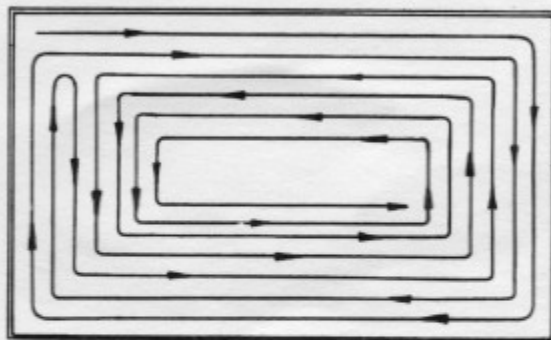

Figure 40. Mowing Pattern

- Never mow wet grass as this can cause chute and blade clogging which reduce the cutting effectiveness and overload the motors.
- Listen to motor noise as an indication of loading. If mower motors slow down and the mower deck vibrates because of loading in tall or thick grass, reduce vehicle speed by selecting next lower gear.

