

# 1975 OWNERS MANUAL

for



FACTORY ORDER NUMBER 3-6000



# WHEEL HORSE

lawn & garden tractors

Price \$1.00



Welcome to the world of Wheel Horse battery-powered lawn and garden equipment!

It is part of a new world of respect for our environment. With today's concern about pollution and shortages of some fuels, we are justly proud of our new A-65 Electric Rider. It is the result of 29 years of experience in building lawn and garden equipment.

We are confident your new Wheel Horse will serve you well. Because it is battery powered, it runs cleaner, quieter and more efficiently.

We look forward to your comments and suggestions as to how we can improve our new A-65. For your convenience we've enclosed a special postage-paid report form. Please take a minute to give us your reactions to our new model!

Remember, we are sincerely interested in your continued satisfaction with our products.

Sincerely,

WHEEL HORSE PRODUCTS, INC.

A handwritten signature in dark ink, appearing to read "C. E. Pond". The signature is fluid and cursive, written over a light-colored background.

C. E. Pond  
Chairman of the Board

# CONTENTS

	PAGE		PAGE
Introduction .....	3	<b>STARTING AND OPERATION</b> .....	11
Specification Chart .....	3	To Start .....	11
<b>PRE-DELIVERY CHECKLIST</b> .....	4	To Stop .....	12
Install Steering Wheel .....	5	To Reverse .....	12
Install Seat .....	5	Mower Operation .....	12
Service Batteries .....	5	Mowing Tips .....	12
Check Wiring .....	6	Cutting .....	12
Install Mower .....	7	Mower Care .....	13
Check Drive Belt .....	7	Attachment Capabilities .....	13
Check Chain Tension .....	7	<b>MAINTENANCE</b> .....	13
Check Clutch Operation and Transmission Shifting .....	7	Lubrication .....	13
Check Tire Inflation .....	7	Visual Inspection .....	14
Lubrication .....	7	Power Pack .....	14
<b>INSTRUMENTS AND CONTROLS</b> .....	8	Mower Installation .....	14
Clutch/Brake Pedal .....	8	<b>SERVICE AND ADJUSTMENTS</b> .....	15
Parking Brake .....	8	Brake/Clutch Adjustment .....	15
Mower Lift .....	9	Chain Drive Adjustment .....	15
Key Switch .....	9	Belt Replacement .....	15
Mower Switch .....	9	Mower Cutting Height Adjustment .....	16
Gear Selector .....	9	Wheels and Tires .....	16
The Charger .....	9	Storage .....	16
Safety System .....	9	<b>TROUBLESHOOTING CHECKLIST</b> .....	17
<b>ELECTRICAL SYSTEM</b> .....	10	<b>WIRING DIAGRAM</b> .....	18
Charging the Batteries .....	10	<b>NEW PRODUCT WARRANTY</b> .....	20
Charger Starting Positions .....	10	<b>BATTERY WARRANTY</b> .....	20
Servicing the Batteries .....	11		
Electrical System Protection .....	11		

## LIST OF ILLUSTRATIONS

FIG.		PAGE
1	Seat Installation .....	4
2	Installation of First Battery .....	6
3	Battery Wiring Diagram .....	6
4	Drive Belt and Chain .....	7
5	Major Instruments and Controls .....	8
6	Clutch/Brake Pedal .....	8
7	Parking Brake .....	8
8	Mower Lift Handle .....	9
9	Gear Selector .....	9
10	Approved Electrical Outlets .....	10
11	Charger Starting Positions .....	10
12	Fuse Panel .....	11
13	Mower Deck Lift Handle .....	12
14	Mowing Pattern .....	13
15	Grease Fittings and Chain Adjustment .....	13
16	Rear Suspension Assembly .....	14
17	Front Suspension Arm Assembly .....	14
18	Mower Spring Installation .....	14
19	Front Mower Suspension and Wiring .....	15
20	Brake Adjustment .....	15
21	Drive Belt .....	16
22	Cutting Height Adjustment .....	16
23	Wheel Removal .....	16
—	Wiring Diagram .....	18

# GENERAL SAFETY SUGGESTIONS

Recommended by Outdoor Power Equipment Institute

## SAFE OPERATION PRACTICES — RIDING VEHICLES

1. Know the controls and how to stop quickly — **READ THE OWNER'S MANUAL.**
2. Do not allow children to operate vehicle. Do not allow adults to operate it without proper instruction.
3. Do not carry passengers. **Keep children and pets a safe distance away.**
4. Clear work area of objects which might be picked up and thrown.
5. Disengage all attachment clutches and shift into neutral before attempting to start engine (motor).
6. Disengage power to attachments and stop engine (motor) before leaving operator position.
7. Disengage power to attachment(s) and stop engine (motor) before making any repairs or adjustments.
8. Disengage power to attachments when transporting or not in use.
9. Take all possible precautions when leaving vehicle unattended; such as disengaging power-take-off, lowering attachments, shifting into neutral, setting parking brake, stopping engine and removing key.
10. Do not stop or start suddenly when going uphill or downhill. Mow up and down the face of steep slopes; never across the face.
11. Reduce speed on slopes and in sharp turns to prevent tipping or loss of control. Exercise extreme caution when changing direction on slopes.
12. Stay alert for holes in terrain and other hidden hazards.
13. Use care when pulling loads or using heavy equipment.
  - a. Use only approved drawbar hitch points.
  - b. Limit loads to those you can safely control.
  - c. Do not turn sharply. Use care when backing.
  - d. Use counterweight(s) or wheel weights when suggested in owner's manual.
14. Watch out for traffic when crossing or near roadways.
15. When using any attachments never direct discharge of material toward bystanders nor allow anyone near vehicle while in operation.
16. Handle gasoline with care — it is highly flammable.
  - A. Use approved gasoline container. Place container out of the reach of children.
  - B. Use gasoline only as a fuel — never as a cleaner. Never remove cap or add gasoline to a running or hot engine or fill fuel tank indoors. Wipe up spilled gasoline. And positively **NO SMOKING.**
  - C. Open doors if engine is run in garage — exhaust fumes are dangerous. Do not run engine (motor) indoors.
17. Keep vehicle and attachments in good operating condition and keep safety devices in place.
18. Keep all nuts, bolts, and screws tight to be sure equipment is in safe working condition.
19. Never store equipment with gasoline in the tank inside a building where fumes may reach an open flame or spark.
20. Allow engine to cool before storing in any enclosure.
21. To reduce fire hazard keep engine free of grass, leaves or excessive grease.
22. Vehicle and attachments should be stopped and inspected for damage after striking a foreign object and the damage should be repaired before restarting and operating the equipment.
23. Do not change engine governor settings or over-speed engine.
24. When using vehicle with mower:
  - (1) Mow only in daylight or in good artificial light.
  - (2) Never make a cutting height adjustment while engine (motor) is running if operator must dismount to do so.
  - (3) Shut engine (motor) off when unclogging chute.
  - (4) Check blade mounting bolts for proper tightness at frequent intervals.
25. Check grass catcher bags frequently for wear or deterioration. Replace with new bags for safety protection.



## CAUTION



1. **KEEP ALL SHIELDS IN PLACE.**
2. **BEFORE LEAVING OPERATOR'S POSITION:**
  - A. **SHIFT TRANSMISSION TO NEUTRAL**
  - B. **SET PARKING BRAKE**
  - C. **SHUT OFF MOTORS**
  - D. **REMOVE IGNITION KEY.**
3. **KEEP PEOPLE AND PETS A SAFE DISTANCE AWAY FROM MACHINE.**
4. **WAIT FOR ALL MOVEMENT TO STOP BEFORE SERVICING MACHINE.**

## INTRODUCING THE A-65 BATTERY POWERED RIDER

The new Wheel Horse A-65 Electric Rider has been designed to be a positive addition to your home and its environment. Thanks to its "Electric Energy System" there are no irritating exhaust fumes. Battery power means a quieter machine, one that won't disturb the neighbors. The A-65 is dependable, because fewer parts mean fewer things to go wrong. Only minimum maintenance is required.

Please take time to read this owners manual thoroughly. It has been carefully written to allow you to operate your new A-65 Electric Rider with complete ease and safety. Preventive maintenance is outlined to help you keep problems from occurring.



### CAUTION



This symbol marks important instructions relating to your personal safety. To avoid the possibility of injury, read and follow such instructions carefully.

When the manual refers to the left or right side of the A-65, it means your left and right when sitting in the driver's seat.

#### SPECIFICATION CHART

##### General

Width (rider) . . . . .	34-1/4 Inches
Width (rider with mower attached) . . . . .	47-3/4 Inches
Length (overall) . . . . .	61-1/2 Inches
Height (overall) . . . . .	39 Inches
Weight (with mower) . . . . .	452 Lbs
Frame . . . . .	Steel
Brake . . . . .	Disk
Front Tires . . . . .	11 x 4.00-5
Rear Tires . . . . .	13 x 5.00-6

##### Drive System

Power Pack . . . . .	3-12 volt units
Transaxle . . . . .	.5 speeds forward & 1 Reverse

# WHEEL HORSE PRE-DELIVERY CHECKLIST

## A-65 ELECTRIC RIDER

The pre-delivery operations and checks on this list should have been performed and signed for by your dealer prior to delivery. If, for any reason, there is an indication that your rider has not been checked, make sure the following operations are performed before starting it.

The A-65 comes completely assembled except for the installation of the steering wheel, the seat, and the initial filling and charging of the batteries. Parts to be installed are found in the separate parts box in the delivery package. These parts are:

Qty.	Description
1	Steering Wheel
1	Dowel Pin
1	Seat
2	Seat Bolts and Hardware
2	Main Switch Keys
1	Owners Manual
1	New Product Registration Card

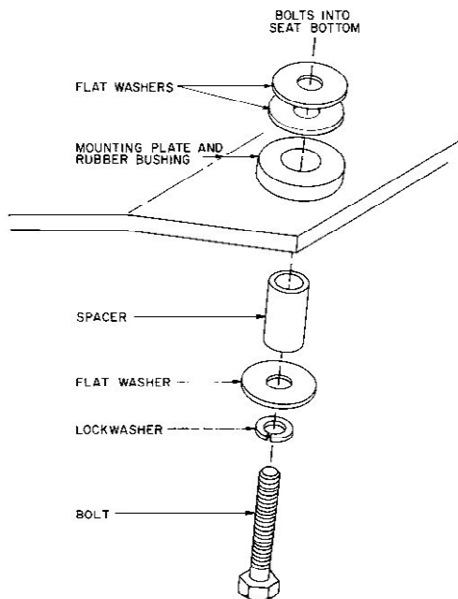

FIG. 1. Seat Installation

## INSTALL STEERING WHEEL

1. Install the steering wheel, lining up the hole in the wheel hub with the hole in the steering shaft.
2. Secure the steering wheel with the dowel pin, centering the pin in the wheel hub so it is the same distance from each end of the hole.

## INSTALL SEAT

1. Mount the seat on the two rubber spacers in the seat support frame. This is done by taking one  $\frac{5}{16}$  x  $1\frac{1}{8}$  inch bolt, placing a  $\frac{5}{16}$  inch lockwasher, plain washer, and metal sleeve over it, sliding it through the rubber spacer, adding two additional  $\frac{5}{16}$  inch washers, and screwing the bolt into the matching hole in the bottom of the seat front. (See Fig. 1).
2. The same procedure is followed for the second bolt for the remaining spacer and matching seat hole.

## SERVICE BATTERIES

### CAUTION

Electrolyte is poisonous and can be injurious to eyes, skin and clothing. In the event of an accident, flush immediately with a solution of one part baking soda to four parts water. Notify physician immediately.

1. **NOTE:** Never install electrolyte with the batteries in the rider. Use only electrolyte with a specific gravity of 1.265.
2. Remove the Wheel Horse "Dry-namic" batteries from the rider. Begin by removing the battery clamp from the top of the batteries.

Disconnect the negative battery cable first, then disconnect the remaining battery cables. **Note the positions of all cables.** (See Fig. 3).

Remove the center battery from the compartment. Slide the remaining two batteries toward the center and remove them from the compartment.

3. Remove the battery caps and fill each cell until the electrolyte is barely  $\frac{1}{4}$  inch above the top of the separators. **Do not overfill.** Replace the caps.
4. To reinstall the batteries, place the first battery in the center of the compartment with the positive terminal forward as shown in Fig. 2.

### CAUTION

Keep loose battery cables from shorting to other connections or the rider itself.

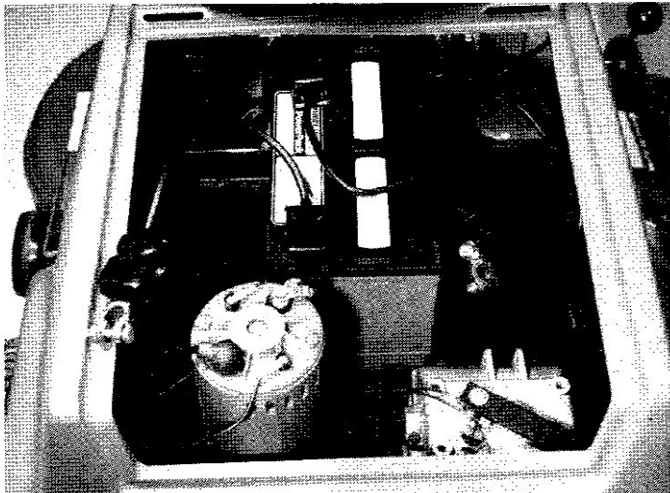

**FIG. 2. Installation of First Battery**

Attach a connecting battery cable to the positive terminal. Attach the rider negative cable to the remaining terminal and slide the battery to the left. Place the second battery in the compartment with the negative terminal forward. Attach the second battery connecting cable to its negative post. Attach the rider positive cable to its remaining terminal. Slide this battery to the right. Place the remaining battery in the compartment. Place the battery hold-down over the threaded ends of the battery clamps and secure. Fasten the connecting cable from the battery on the left to the negative terminal of the center battery. Fasten the cable from the battery on the right to the positive terminal.

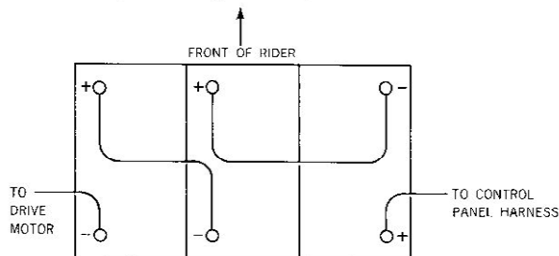

**FIG. 3. Battery Wiring Diagram**

5. Make sure all connections are tight. Cover the battery terminals and clamps with a light coat of grease. Then cover terminals with protective caps.
6. Register the batteries by removing the month and year of installation circles from the decal on each battery.
7. Charge the batteries, referring to **Electrical System** section, "Charging the Batteries".

**CHECK WIRING**

1. Visually check all wiring for loose connections and tighten as required. Check the routing of all wires to make sure they will not interfere with any moving part, causing a short.

**INSTALL MOWER**

1. Install mower according to "Mower Installation" section of this manual.
2. Adjust mower height (See **Service and Adjustments** section, "Mower Cutting Height Adjustment").

**CHECK DRIVE BELT**

1. Be sure belt is in proper place and belt-keeper is properly located. (Fig. 4).

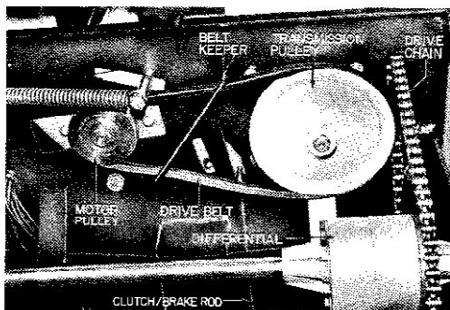

**FIG. 4. Drive Belt and Chain**

**CHECK CHAIN TENSION** (See Page 15).

**CHECK CLUTCH OPERATION AND TRANSMISSION SHIFTING**

**CHECK TIRE INFLATION**

The tires have been overinflated for shipping. Reduce the pressure as follows:

Front Tires . . . . . 15 PSI  
Rear Tires . . . . . 12 PSI

**LUBRICATION**

Apply a light coat of engine oil to the full length of the drive chain. Liberally grease the front wheel bearings. Grease both ends of the lift bars, and the rear axle bearings. Oil the rear axle shaft ends to prevent rust.

Work performed on \_\_\_\_\_ Date \_\_\_\_\_

Dealer signature \_\_\_\_\_  
Authorized Wheel Horse Dealer

**⚠ CAUTION ⚠**

The preceding section covering pre-delivery inspection should have been completed by a Wheel Horse dealer. Failure to complete the pre-delivery inspection on your new Wheel Horse A-65 Electric Rider prior to its first use may affect the warranty.

## MOWER LIFT (Fig. 8)

The mower lift is used to raise and lower the mid-mounted mower. Cutting height may be adjusted with this handle for short, quick adjustments. For best mowing results the mower height should be adjusted at the mower height adjustment wheels. (See Fig. 22). After adjusting the wheel height, always lower the mower lift handle to the bottom position for free mower movement.

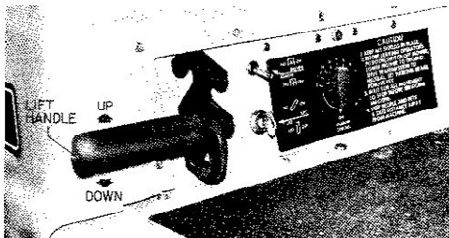
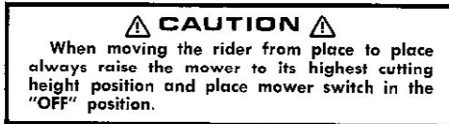
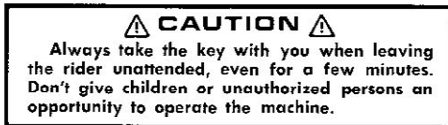

FIG. 8. Mower Lift Handle

## KEY SWITCH (Fig. 5)

The "OFF" position of the key switch disconnects all electrical circuits with the exception of the charger. The charger circuit is active with the key in either the "OFF" or "ON" position. The clockwise "ON" position allows power to be supplied to the main drive and mower motors. The main drive motor is started after shifting to neutral and turning the key switch to "ON". The mower motors can then be started by moving the mower switch to "START".



## MOWER SWITCH (Fig. 5)

Before this circuit is operative the drive motor must be started in the normal manner. With the mower properly installed and the drive motor running, start the mower by holding the switch in the "START" (Up) position momentarily. When the switch handle is released it automatically returns to the center "RUN" position. To stop the mower, move the switch down to the "OFF" position.

## GEAR SELECTOR (Fig. 9)

The position of the gear selector lever determines one of five forward speeds and one reverse, according to the pattern shown in Fig. 9.

Gear selection is made with a quick positive hand motion, with the clutch/brake pedal depressed.

The rider may be shifted while in motion by depressing the clutch/brake pedal to the point where the drive belt is released its maximum amount, yet before braking begins.

**NOTE:** When the gears do not mesh immediately, slightly release the clutch/brake pedal to free the gears, then move the lever to the desired position.

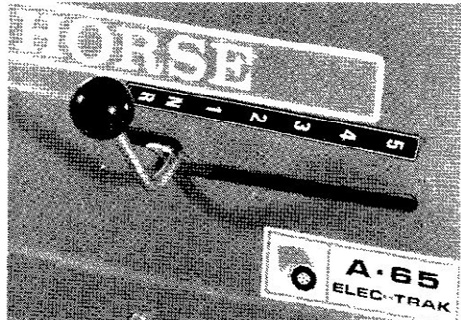
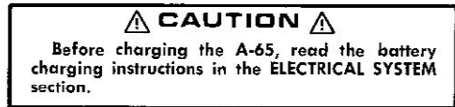

FIG. 9. Gear Selector

## THE CHARGER

When turned on, the charger replenishes power pack energy.



It is especially valuable to put the rider on charge during any short breaks in operation (10 minutes or longer), since the high rate of input during the early part of the charging cycle reactivates the power pack (the batteries) and prolongs the work period.

Since a new power pack has a break-in period, it is recommended that deep discharging (when mower blades first show appreciable speed reduction) be avoided for the first five periods of operation. This will help prolong the life of the batteries.

## SAFETY SYSTEM

### Seat Switch —

The seat must be occupied in order to close a switch which permits the drive motor and mower circuitry to operate. If the seat is vacated for any reason all power circuits are shut off. Under normal operation only the key switch and mower switch should be used for turning off power.

### Return-to-off —

If power to the mower is interrupted by either the seat switch or turning the key switch to "OFF", it cannot be restored until the drive motor has been restarted and the mower switch turned to "START" (fully up) and then "RUN".

If power to the drive motor is interrupted, the transmission must be returned to neutral to restart.

**⚠ CAUTION ⚠**

These safety devices are used to provide maximum safety for the operator of the A-65 Rider. They should never be altered and should always be kept in good working order.

## ELECTRICAL SYSTEM

The A-65 gets its power from its "Electrical Energy System". Three special Wheel Horse 12 volt batteries supply power to both the traction drive motor which moves the rider, and both mower blade motors. To "refuel" the rider the batteries must be recharged.

**⚠ CAUTION ⚠**

Under no circumstances should automotive electrical equipment such as lights, horns, or any grounded frame device be attached to the rider. The rider frame is not grounded and such devices could cause damage to the control system and a potential safety hazard if used.

## CHARGING THE BATTERIES

The A-65 is designed to refuel itself and always be ready to use if the charger is plugged in and the charger dial is turned to the appropriate "START" position. It should always be plugged into a standard 115 volt grounded outlet when not in use.

**⚠ CAUTION ⚠**

1. Check to see if your 115 volt outlet is a grounded type. (Fig. 10A).
2. Or, as an alternative, you may use an adapter if your electrical outlet is internally grounded. (Fig. 10B).

If in doubt, consult a qualified electrician.

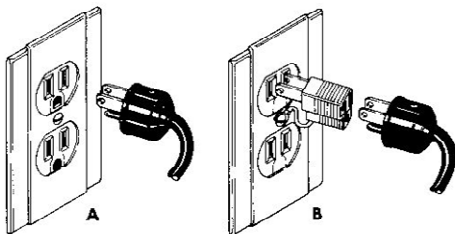

FIG. 10. Approved Electrical Outlets — Standard Grounded & Adapter Ground

**⚠ CAUTION ⚠**

Use of an improperly grounded outlet could result in electrical shock.

The charger is designed to restore a full charge to the rider power pack (set of batteries) after one cycle of operation. Under normal conditions the charger will run up to 19 hours to equalize cell voltages (when started at the "A" position). Older power packs require

less charging time. The charger runs independently of the rider key switch. Always remove the key to prevent unauthorized use of the rider.

## CHARGER STARTING POSITIONS

The amount of charging a power pack needs depends on three things:

1. The accumulative number of hours of operation since the last charge.
2. The temperature of the batteries.
3. The age of the batteries.

The charger dial starting positions are lettered "A" through "J". Position "A" is a very long charging period; position "J" is about half as long. The best indicator of the power pack's charging requirements is the amount of water to be added. If water must be added after one to three charges, the charger should be started at the next letter **below** that of the previous charge, for example, from "C" down to "D". The charger setting should not be varied more than one letter at a time, and two or more charges should be made before using a new knob setting. (Fig. 11)

As the batteries age and go through more charging cycles, the charging period can be decreased. Typical homeowner use allows a full charge to occur if started in the "A" to "D" position during the first to second year and "D" to "F" position after the second or third year of use.

As temperatures decrease, the charge time must be increased. For example, a power pack discharged to the same level will require as much as 50% more charge time for full recovery at 30°F. than at 70°F. In very cold weather the "A" position can usually be used for all charging.

When in doubt, it is better to overcharge (charge too long) than to undercharge, as long as there is not a high loss of water during charging.

**NOTE:** A deeply discharged power pack requires the charger to draw approximately 7-amperes from the 115 volt receptacle. To prevent 15-ampere household fuses or circuit breakers from "opening" and interrupting power, it may be necessary to disconnect other appliances, tools or lights from that circuit.

When the power pack is fully charged, the charger shuts off automatically. It is advisable to leave it plugged in after completion of the charging cycle. If the rider is needed, however, the charger may be turned off and unplugged any time after the charging cycle.

**NOTE:** The power pack should not be charged in an area where the temperature is above 110°F. to prevent overheating and possible damage to the batteries.

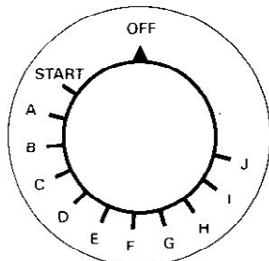

FIG. 11. Charger Starting Positions

### ⚠ CAUTION ⚠

When servicing the batteries or any other part of the electrical system, or if the batteries must be removed for any reason, remove personal metal objects: rings, bracelets, etc., to avoid the possibility of electrical shock.

## SERVICING THE BATTERIES

During the late stages of the charging cycle there is a bubbling action or gassing process which allows some water in the electrolyte solution to evaporate. During this procedure only water is lost, so it is only necessary to add water to bring the electrolyte level up to the proper point. Distilled water, or tap water of low to average mineral content, is satisfactory for this purpose.

Water should be added only after the power pack is charged. The only exception to this rule is if the water level should fall below the top of the plates. Sufficient water should be added to bring the electrolyte level just above the plates. The system should then be charged and additional water added if necessary.

### ⚠ CAUTION ⚠

Electrolyte and battery fluid are poisonous and can be injurious to eyes, skin and clothing. In the event of an accident, flush immediately with a solution of one part baking soda to four parts water. Notify physician immediately.

Any electrolyte running out of the top of the cells is an obvious sign of overfilling. It is important that the electrolyte level be maintained  $\frac{1}{4}$  to  $\frac{3}{8}$  inch above the plates and never above the indicator ring. Overfilling can result in dilution of the electrolyte which reduces the capacity and life of the batteries. Overfilling can also cause corrosion when spillage of electrolyte occurs.

Under normal conditions it will only be necessary to check the electrolyte approximately once per month. Use of the rider in higher temperature locations or under very heavy use may require more frequent checks. After several years of use it may be necessary to add water more often.

### ⚠ CAUTION ⚠

During the charging process hydrogen gas is formed. Always remove the battery compartment cover and charge batteries only in well-ventilated areas. Do not charge near flames. Do not smoke near the rider during the charging process.

### WARNING!

Only special Wheel Horse batteries may be used as replacements. Failure to follow this warning may negate the battery warranty.

## ELECTRICAL SYSTEM PROTECTION

Protective devices are used on the A-65 Riding Mower to protect electrical components and wiring. These devices detect both high current and high temperature, and will sense potentially severe conditions that could damage components or circuits. Under such conditions they remove power from the circuit involved.

Two types of protective devices are used — automatic reset circuit breakers and replaceable fuses. One type of automatic reset circuit breaker is located within the drive motor. If it should open due to high motor temperature, it will reclose automatically following a short cooling-off period. Operation can then be restored following normal starting procedure. Each mower motor is also protected by its own automatic reset circuit breaker which also resets automatically after a short cooling period. If these circuit breakers frequently interrupt mower operation, refer to the "Troubleshooting Check List" of this manual.

In addition to the circuit breakers, three automotive-type fuses protect the rider systems. They are located in the rear compartment. (See Fig. 12). Two 30-amp slow-blow fuses (one for each motor) protect the mower motors. The third 20-amp fuse protects the charging circuit. In addition, there is a protective fusible link mounted on the front panel to protect the heavy-duty wiring system against heavy overload.

Continued interruptions of power by any circuit breaker is a signal to reduce the load by selecting a lower speed or higher cut, to search for a fault such as jamming, or of an electrical problem requiring dealer service.

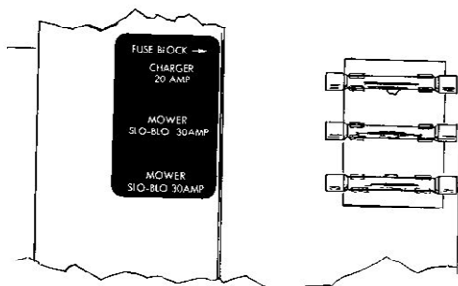

FIG. 12. Fuse Panel

## STARTING AND OPERATION

### To Start:

1. Disconnect the charger cord and place it around the cord wrap in the rear compartment.
2. For safety reasons, the rider will not start unless the operator is in the seat and the gear selector lever is in neutral.
3. Start the drive motor by turning the key switch to "ON".
4. Depress the clutch/brake pedal and release the parking brake.

5. Move the speed range selector to the desired position (1, 2, 3, 4, 5 or reverse). A slight release of the clutch/brake pedal will facilitate shifting.
6. Slowly release the clutch/brake pedal.

**NOTE:** Complete depression of the clutch/brake pedal provides maximum braking with no transfer of power to the transmission. Partial depression of the pedal allows the rider to creep, or regain forward motion after stopping uphill. Avoid prolonged riding of the pedal during operation to prevent excessive wear.

**To Stop:**

1. Depress the clutch/brake pedal to stop the rider. To stop the drive motor, turn the key switch to "OFF".
2. Set the parking brake.

**To Reverse:**

1. Depress the clutch/brake pedal to stop the rider.
2. Move the range selector to the reverse ("R") position.
3. Slowly release the clutch/brake pedal.

## MOWER OPERATION

**To Start:**

1. The mower will not operate unless the rider drive motor has been started. Start the rider, then set the mower deck lift handle in the bottom (free-floating) position.

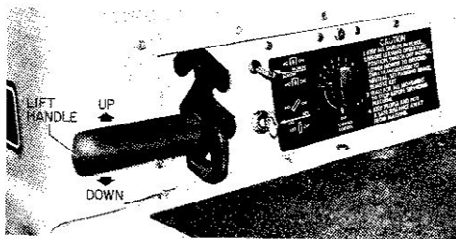

**FIG. 13. Mower Deck Lift Handle**

2. Lift the mower switch to "START" position. After the mower motors start, release the lever and it will automatically return to the center "RUN" position.

**To Stop:**

Push the mower switch down to the "OFF" position.

**NOTE:** Installation procedures and operating instructions for attachments other than the mower are on a separate parts list and instruction sheet packed with each attachment.

**⚠ CAUTION ⚠**

Heavy hauling or impact pulling should not be attempted with the A-65 Rider.

**⚠ CAUTION ⚠**

Climb steep hills in first gear only. Don't attempt steep climbs at high speed.

## MOWING TIPS

For average mowing, gears 2 and 3 are recommended. Gears 3 and 4 may be used for lighter duty, faster mowing. If the cut is not clean and even, a lower gear selection or a higher cutting height should be used. For greater control, the lower gears should be used on steep hillsides.

When mowing steep hills the direction of travel should always be up and down. Exercise care to avoid sudden stops and starts which may cause loss of control. The rider motor offers some braking action provided the clutch/brake pedal is not depressed and the rider is left in gear. First gear offers the most motor braking.

## CUTTING

Always mow with sharp blades. The blades should be sharpened and balanced seasonally if subjected to average use, or whenever cutting quality deteriorates. **Always disconnect the motor power cords before servicing or adjusting the mower.** After each sharpening, if mower vibration is noticeable, the blades should be checked for balance. Unbalanced blades will shorten the life of the mower motor bearings.

For good appearance of the mowed lawn, it is very important to have the mower adjusted correctly for height of cut. (See section on "Mower Cutting Height Adjustment".)

The best height of cut should be determined by positioning the rear mower wheels in the second lowest adjusting hole for the first few passes. If the grass is not cut short enough, use of the third-lowest hole will give a 1/8-inch shorter cut, and so forth. Care must be used not to scalp uneven parts of the lawn by cutting too close.

Experience in operating the equipment under various conditions is very important in obtaining maximum efficiency and the best appearance. After a few hours of operation, mower motor and blade loading can be easily determined by the change in sound produced. If the turf is very soft or the grass is very heavy the blade noise and mower vibration may increase, signaling overloading. In this case, it is suggested that the lift lever be raised until the weight of the mower is first felt and then lock the lift in the next higher position. After mowing with the mower in this position, if it is desired to cut the grass shorter, another pass with the mower fully lowered should be made. If the grass is not too long, shifting into a lower gear may eliminate the need for raising the mower.

On average lawns that have merely grown too long it may be necessary to mow on two passes in the same manner as described above to prevent clogging of the chute. This would also be the method used to mow very high grass or weeds, but the initial pass should be made with the mower in its highest cutting position.

When sections of rough terrain or an area which may contain small stones is encountered, the operator should constantly adjust the lift lever to the conditions to prevent damage to the equipment or injury to the operator or bystanders.

If the rider appears to groove the lawn or gives a bumpy ride, check the tire pressure. The pressure should be 12 psi rear, and 15 psi front.

## MOWER CARE

1. It is recommended that the underside of the mower deck be cleaned frequently to maintain maximum mowing effectiveness and reduce the likelihood of blade clogging. The mower must be removed to facilitate effective cleaning.

### **CAUTION**

The use of water can damage bearings in motors.

2. Mow high grass by making two passes, the first pass with the mower in its highest position. If there are low obstructions such as twigs or small stones in the mowing area, the second pass should be made with the mower still at a high setting to accommodate the obstructions.
3. Sharpen and balance blades as required, but at least seasonally.
4. Oil mower wheel axles and lift pivot points frequently with a 30 weight machine oil as indicated in the "Lubrication" section of this manual.
5. Turn to the right when beginning to mow large open areas to discharge clippings away from borders such as sidewalks, fences, driveways, etc. After making two or three passes this way, mow in the opposite direction turning to the left to finish. (See Fig. 14).
6. Turn to the left as much as possible so that grass clippings will be discharged evenly to the right over grass already cut. Turning to the right causes a build up of grass clippings which prevents uniform cutting and causes an unnecessary load on the mower.
7. Avoid mowing wet grass as this can cause chute and blade clogging which reduces the cutting effectiveness and overloads the motors.
8. Listen to the sound of the motor as an indication of loading. If mower motors slow down and the mower deck vibrates because of loading in tall or thick grass, reduce vehicle speed by selecting the next lower gear.

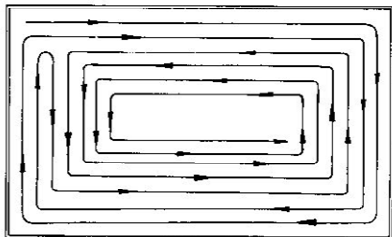

FIG. 14. Mowing Pattern

### **CAUTION**

Keep all shields and mower discharge chute in place. Never attempt to clear discharge chute or mower blades without turning main key switch "OFF" and removing the key.

## ATTACHMENT CAPABILITIES

The A-65 Rider can safely tow loads up to 250 pounds. The following attachments are available to increase the usefulness of your new rider.

DUMP TRAILER	Model 7-2212
LAWN ROLLER	Model 7-2312
AERATOR	Model 7-2412
LAWN SWEEPER	Model 7-2513

## MAINTENANCE

### LUBRICATION

All electric motors in the rider are permanently lubricated. Several high-friction points do require periodic lubrication to prolong life and give maximum satisfaction.

Twice a year, or every 20 operating hours, the front spindles and rear wheel bearings should be greased with a hand grease gun using a No. 2 multipurpose lithium grease. (See Fig. 15). Pump the gun until dirt and old grease are flushed out and wipe all surfaces clean. The underside of the motor plate should be greased liberally at the three corners not secured to the rider frame.

All linkages and bearings should be oiled with a heavy-duty (No. 30) machine oil. Major points to be considered include:

1. Clutch/brake pedal pivot and linkage connections.
2. Mower mounting pins.
3. Lift assembly pivot points.
4. Rear axle chain.
5. Front axle pivot pin.
6. Lift bars.

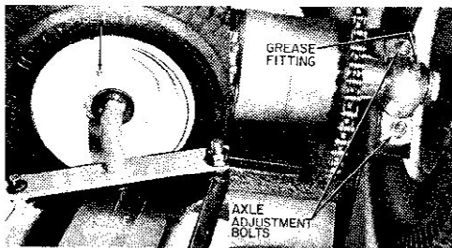

FIG. 15. Grease Fittings and Chain Adjustment

Prevent dirt and dust accumulation by wiping away all excess oil. These lubrication recommendations are a guide only. If the rider is subjected to abnormal environmental conditions or heavy use, the frequency of lubrication and other preventive maintenance measures should be increased accordingly.

## VISUAL INSPECTION

Periodic inspection of the rider is an important preventive maintenance measure. Make it a habit to visually check for loose fastening devices or any evidence of abnormal operation. Inside storage or covering of the rider plus regular cleaning and polishing of exterior surfaces will keep the rider in good condition. Adjustments, inspections and maintenance procedures should be performed at regular intervals to assure trouble-free economical operation.

## POWER PACK

Charge and add water to the batteries as outlined in this manual. Keep the tops of the batteries clean. Remove accumulations of dirt, grass clippings and so forth to assure optimum electrical system performance. An occasional wiping with wet paper towels is sufficient.

### ⚠ CAUTION ⚠

For personal safety and protection of equipment, always unplug the charger when cleaning power pack surfaces.

## MOWER INSTALLATION

### ⚠ CAUTION ⚠

The mower comes with blades attached and should not be electrically connected until it is fully mounted and the blades have been checked for tightness.

1. Drive the rider to a flat, level surface and remove the key. Lower the mower lift handle to its lowest position.
2. Place the mower under the rider in its approximate mounted position. (See Fig. 5).
3. Lift the "Z" bracket from the mower deck and place the short end over the right rear suspension pin of the rider (after removing the hairpin cotter). Place the long end over the left rear suspension pin of the mower.
4. Install the rear suspension arms over the rear suspension pins of the mower and rider on the right side. Stretch the spring connected to the second suspension arm (the spring goes under

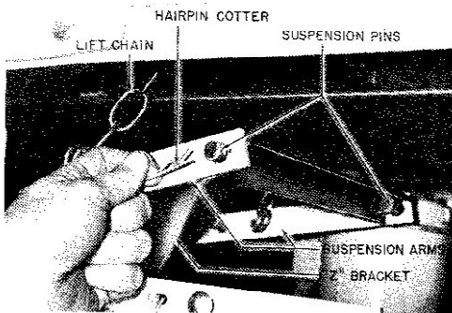

FIG. 16. Rear Suspension Assembly

the "Z" bracket) and snap the arm onto the suspension pins on the left side.

5. Secure the ends of the suspension pins to the "Z" bracket with hairpin cotters. (See Fig. 16).
6. Remove the remaining set of suspension arms from the mower deck. Attach them to the front set of suspension pins the same way the rear arms were installed. (See Fig. 17).

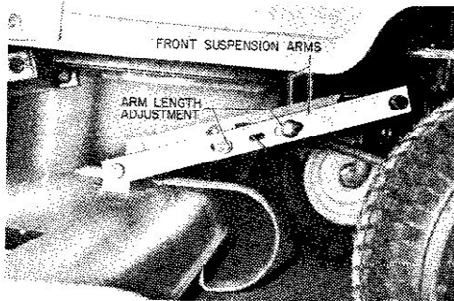

FIG. 17. Front Suspension Arm Assembly

7. The front arm lengths can be used for leveling the mower in mowing position. These arms are factory set and should not require adjustment.
8. Lift the mower with the manual lift. Remove the mower helper spring attached to the seat support through the rear compartment. (See Fig. 18). Attach the lower end to the hole in the rear of the mower deck support directly in back of the rear suspension arm lift pins. Stretch the spring and refasten it to the seat support from which it was removed. Install the second spring on the opposite side in the same way. If the batteries are in place, attach the upper end of the spring next to the seat support and stretch the spring from under the rider to fit into the mower deck support hole.

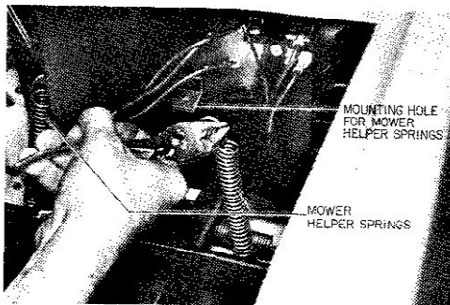

FIG. 18. Mower Spring Installation

9. Join each mower motor power cord connector to its corresponding power cord coming out of the bottom of the frame. (See Fig. 19).

**NOTE:** The connector halves are keyed to fit together only one way to establish proper polarity.

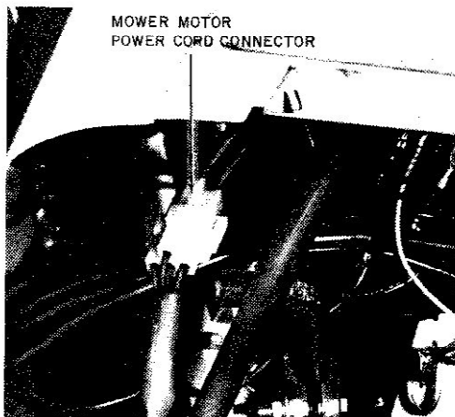

FIG. 19. Front Mower Suspension and Wiring

**⚠ CAUTION ⚠**

Always disconnect both pairs of motor power cord connectors before handling the mower for any reason.

**⚠ CAUTION ⚠**

Turn main key switch "OFF" and remove key from switch before touching blades.

To sharpen the blades, remove the attaching bolt and washer, and lift the blade off the motor. File or grind the blade, taking care to retain the original cutting edge angle as well as blade balance. Inspect carefully for cracks or other damage which might weaken the blade and make it dangerous to reinstall. Replace the blade if damage is found.

Reinstall the blades, making sure the side of the blade with the lift area (turned up section) is facing the mower deck. Tighten the blade-attaching bolts to a torque of 35 ft./lbs. Replace these bolts every second or third time they are removed. Use only the special bolts available from your local authorized Wheel Horse dealer.

## SERVICE AND ADJUSTMENTS

**⚠ CAUTION ⚠**

Before making any adjustment, turn main key switch "OFF" and remove key from the switch.

### BRAKE/CLUTCH ADJUSTMENT (Fig. 20)

#### NORMAL ADJUSTMENT

1. Depress the clutch/brake pedal to within 1 inch of full depression (to be measured at the opening in front of the pedal).
2. Turn the brake adjustment nut until the brake disc firmly holds the wheels.

3. Check the operation of the clutch/brake action. Make certain that the traction motor is de-clutched before brake engagement begins.
4. Lock the brake adjustment nut with the outer locknut.

#### MAJOR ADJUSTMENT

The following adjustment was made at the factory. If it should be required due to extreme belt wear, or if the belt is being replaced, proceed as follows:

1. Adjust the clutch/brake rod by removing the pedal clevis pin and adjusting the clevis so that the pedal shaft is vertical, or in the extreme rear of the slot. Replace the clevis pin and secure with a cotter pin.
2. Remove the clevis pin from the transmission brake lever and adjust the clevis so that the brake lever rod length lies from the rear edge of the motor plate slot to the transmission brake lever hole when the lever is vertical. Replace the clevis and secure with a cotter pin. **NOTE:** It will be necessary to loosen the brake adjustment nut to free the lever for clevis pin installation. Reset the brake adjustment nut as indicated in Step 2 of the "Normal Adjustment".

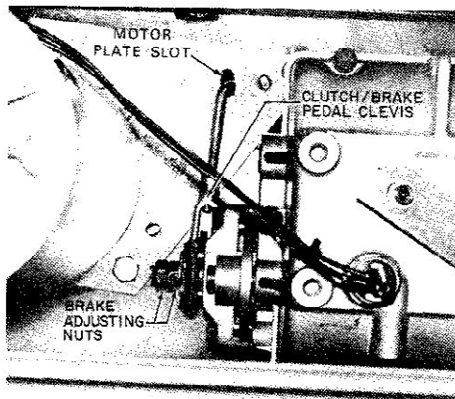

FIG. 20. Brake Adjustment

#### CHAIN DRIVE ADJUSTMENT

Chain adjustment is made by loosening the four bolts holding the rear wheel bearings in place and sliding the axle assembly forward or backward. Retighten the four bolts after tightness is achieved. (See Fig. 15). Make sure the chain is squarely aligned on each sprocket.

#### BELT REPLACEMENT

Power is transmitted from the drive motor to the transmission through a heavy-duty direct-coupled belt. The belt should be kept free of grease, oil, electrolyte and dressings, and checked occasionally for tightness to assure best performance.

Replacement belts are available only through your local authorized Wheel Horse dealer. To change the belt, place the rider on a level area, set the gear

selector in neutral, remove the key and set the parking brake. This will release the tension on the belt and free it from the pulley. Slide the belt under the belt keeper and off the second pulley. Install the new belt reversing this procedure. Refer to Fig. 21.

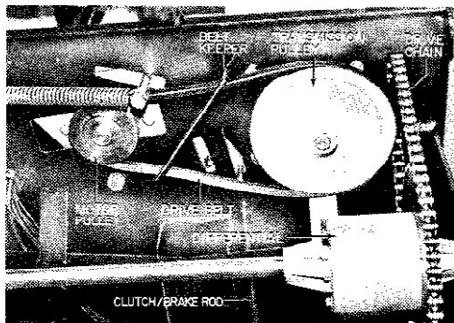

FIG. 21. Drive Belt

## MOWER CUTTING HEIGHT ADJUSTMENT

Adjust the cutting height at the rear mower wheels as follows:

1. Remove the key and turn the mower "OFF".
2. Raise the mower to the uppermost position.
3. Remove the center bolt of each rear wheel.
4. Relocate the bolts in the desired position.

**NOTE:** The upper adjustment hole gives the lowest cutting height and the lowest hole gives the maximum height. The other adjustment holes allow intermediate cutting heights in  $\frac{1}{2}$  inch increments.

5. Secure the wheel assemblies in the desired position with nuts and lockwashers, making sure each wheel uses the same adjustment hole to keep the mower level.

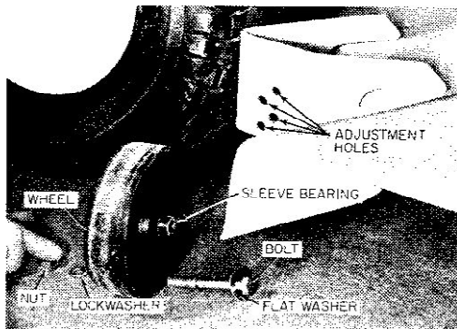

FIG. 22. Cutting Height Adjustment

## WHEELS AND TIRES

Proper tire inflation is an important factor in tire life. Pressures should be checked on a monthly basis and corrected, if necessary, as follows:

### Tire Inflation

Front .....	15 PSI
Rear .....	12 PSI

Avoid all stumps, holes and sharp objects. Any cuts occurring in the tires should be repaired immediately.

Special snap ring pliers are required for removal and replacement of wheels. The rear axles are slotted and the wheel rims protrude into the axle slots. To remove a wheel, take off the snap ring and pull the rim straight off of the axle. Grease the axle before replacing the wheel.

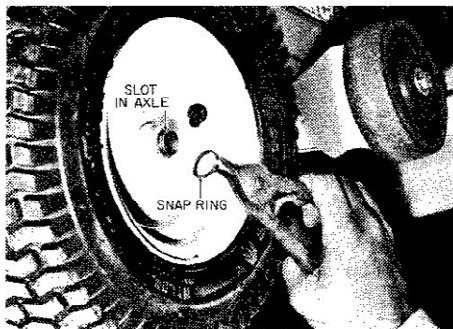

FIG. 23. Wheel Removal

## STORAGE

When storing the rider follow these guidelines:

1. Fully charge the power pack by setting the charger knob to the appropriate starting position, and letting the charger operate until it shuts off.
2. Add water to each battery cell to the proper level only.
3. The rider may be stored in the cold, provided the power pack is charged. A discharged power pack can freeze in cold temperatures unless recharged immediately after use. The following table illustrates the relationship between the amount of charge and the freezing temperature of electrolyte.

Amount of Charge	Freezing Temperature of Electrolyte
100%	-80°F
75%	-42°F
50%	-16°F
25%	+ 2°F
10%	+ 7°F

Self-discharge of a fully charged power pack is practically non-existent below 40°F, and the rider can be stored for several months without attention when not used.

- If stored in a warm area above 40°F, the electrolyte should be checked with a hydrometer once a month. Recharge the power pack if the electrolyte specific gravity is below 1.200.
- Wipe oil on any rider parts that may be affected by rust.

**REMEMBER:** The charge retention (without using additional electricity for recharging) of the batteries can be extended considerably if the rider is stored in a very cool place. Lower temperature slows self-discharge. At temperatures below 40°F virtually no self-discharge occurs.

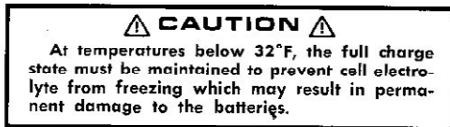

## TROUBLESHOOTING CHECK LIST

### Indication

### Possible Causes

Drive motor does not run.

Sit in seat, shift to neutral.

Key switch not turned to "ON".

Mower inoperative, but drive motor runs.

Motor temporarily overheated.

Proper mower starting sequence not followed.

Mower motor power cord connectors not joined. (1)

Fuses blown or motors overheated. (2)

Only one mower motor will operate if the fuse of the other motor has blown.

Reduced rider range.

Charger not started at proper dial setting.

Brake dragging. Readjust.

Power pack electrolyte level low.

Tires underinflated.

Failure to fully release clutch/brake pedal on long runs.

Improper lubrication.

Improper gear selection.

Loose or corroded battery cable connections.

Power Pack not charging.

20-amp fuse blown.

Charger not plugged into 115-V AC outlet.

115-V AC outlet inoperative due to open household fuse or circuit breaker.

Failure to start charger at proper dial setting.

(1) If one motor is unconnected, neither will operate.

(2) If the circuit breaker on the motor goes out, both mower motors will stop. This circuit breaker will automatically reset itself. After it has reset itself the mower switch must be turned to "START" again to turn the mower on.

WIRING-DIAGRAM

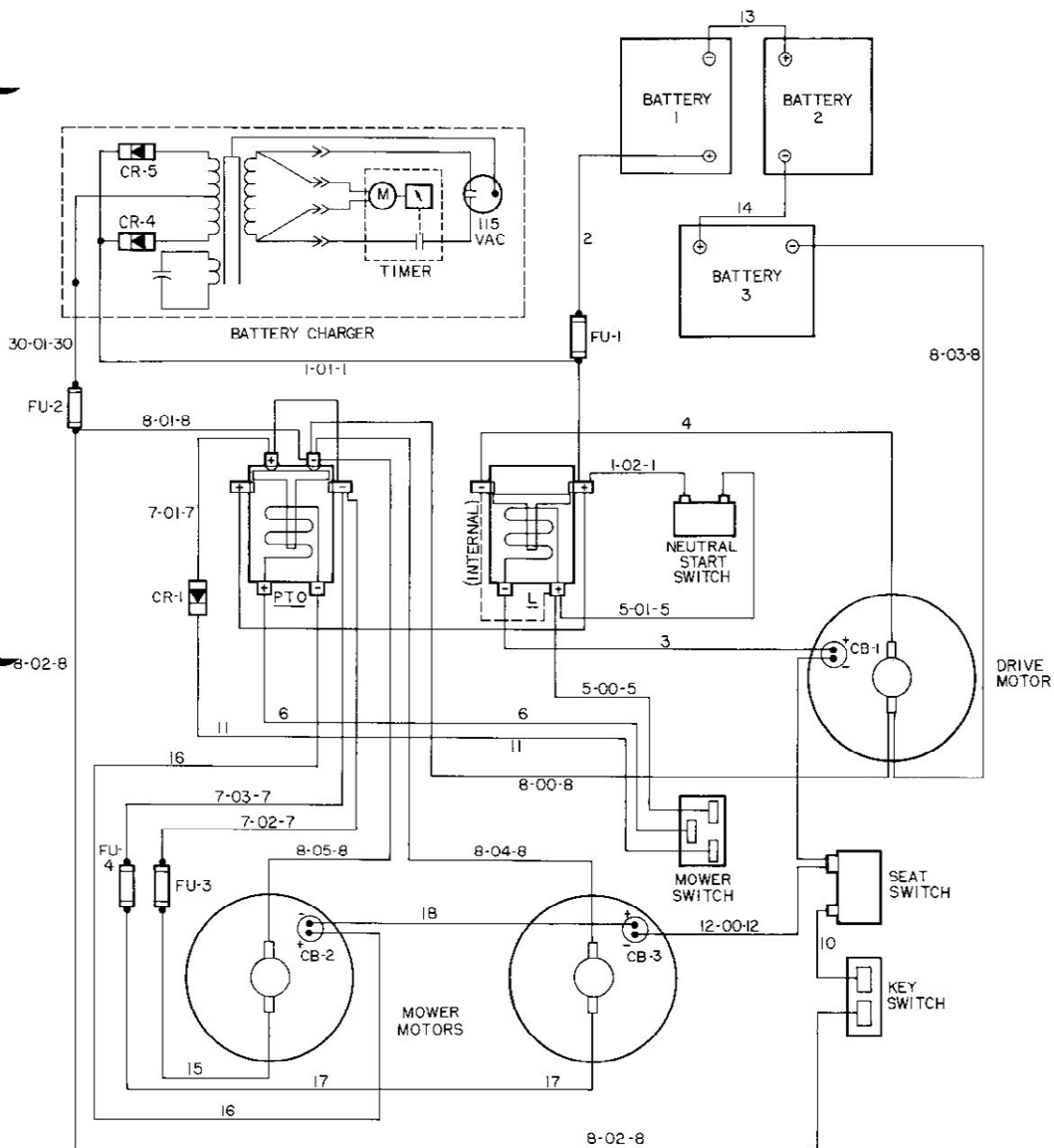

MOWER SWITCH

