

INSTALLATION INSTRUCTIONS FOR EGT-80 HEAVY

DUTY CONVERSION KIT. BUNDLE NO. 080-0007.

The Heavy-Duty Kit is designed to convert standard EGT-80 Electric Garden tractors to a Heavy-Duty model. The heavy-duty version, in addition to having extended range-per-charge over the standard EGT 80 is equipped with an additional set of mower blades. These are the high profile blades (black), which give a high discharge velocity whereas the standard low profile blades (yellow) give extended mowing range with lower discharge velocity.

INSTALLATION

WARNING: Remove the battery clamp terminating cable 2-01 from the positive post of battery B2 and replace the battery cover before proceeding with this installation. Do not lower the control panel on the exposed battery terminals.

1. Remove the screws retaining the control panel and lower panel to the top of the battery cover.
2. Remove the timer and power cord assemblies. Install the new timer furnished so that it indicates "Off" in its detent position. Reinstall the power cord with its strain relief grommet 19 inches from the terminated end of the cord. See Fig. 1. Refer to Fig. 2 for rewiring information.
3. Remove the rear battery box cover and seat. Locate and drill two 5/16-inch diameter holes in the back wall of the rear battery compartment using the template provided, as shown in Fig. 3.
4. Remove all loose parts and metal chips from the rear battery compartment.
5. Temporarily remove the cross-bar which is mounted over the rear battery compartment.

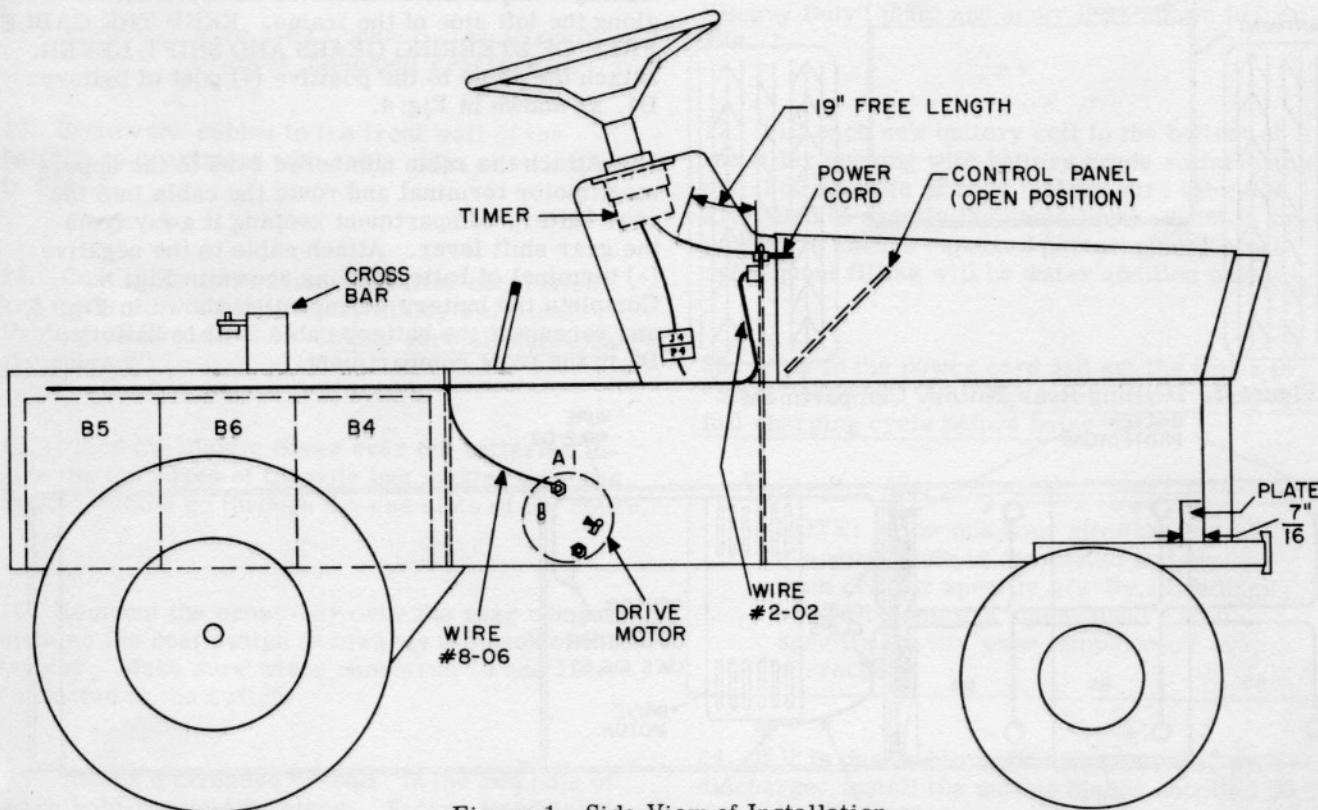

Figure 1. Side View of Installation

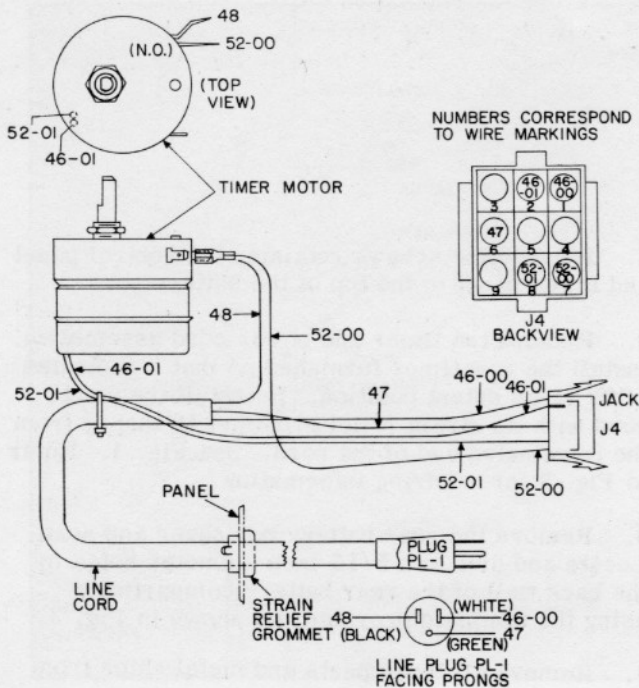

Figure 2

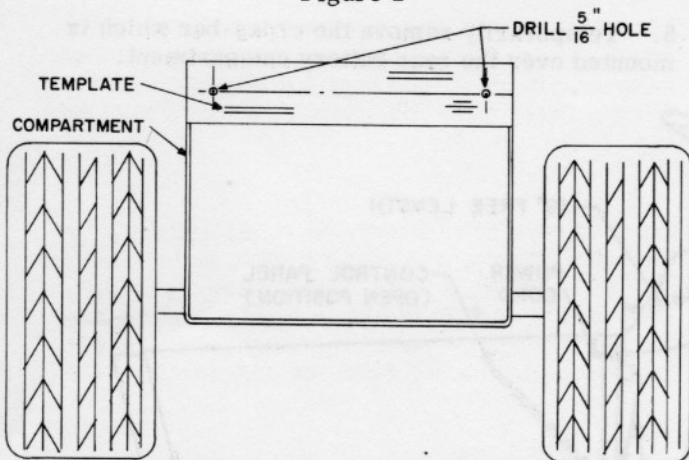

Figure 3. Drilling Rear Battery Compartment

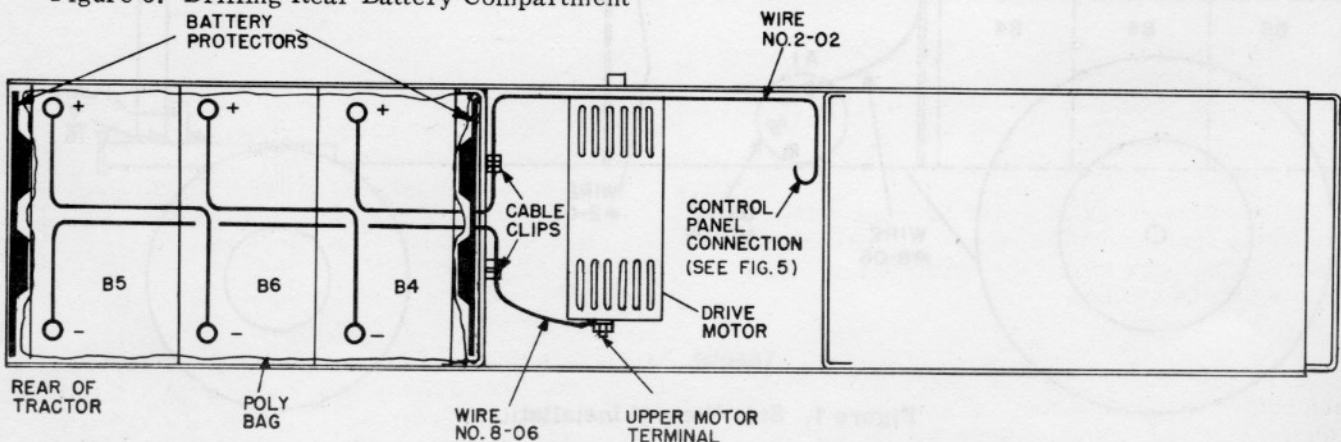

Figure 4. Wiring and Battery Layout

6. Place the battery tray in the bottom of the rear compartment so its drain hole lines up with the drain hole in the floor of the compartment.

7. Unfold the poly bag and place it in the tray so the bag's bottom seam runs from front to rear. Flatten the pockets that form at the seam ends so the bottom of the bag conforms to the tray.

8. Place the vacuum-formed battery protector between the poly bag and the compartment wall at each end of the compartment. Position the protectors so their corrugations will face the battery walls. See Fig. 4.

9. Carefully set the batteries in the bag as shown in Fig. 4 so the sides of the bag remain above the top surface of the batteries in equal amounts. (It may help to tape the upper edges of the bag to the compartment sides temporarily to permit easy insertion of the batteries.) **DO NOT CONNECT BATTERY CABLES AT THIS TIME!**

10. Remove the "H" plate which contains the shift lever and covers the drive motor.

11. Attach the battery cable numbered 2-02 to the insulated stud or the circuit breaker as required. See Fig. 5. Route the cable toward the rear battery compartment under the control cabinet along the left side of the frame. **KEEP THE CABLE FREE OF STEERING GEARS AND SHIFT LEVER.** Attach the cable to the positive (+) post of battery B4, as shown in Fig. 4.

12. Attach the cable numbered 8-06 to the uppermost motor terminal and route the cable into the rear battery compartment keeping it away from the gear shift lever. Attach cable to the negative (-) terminal of battery B5 as shown in Fig. 4. Complete the battery wiring, also shown in Fig. 4, and reconnect the battery cable 2-01 to battery B2 in the front compartment.

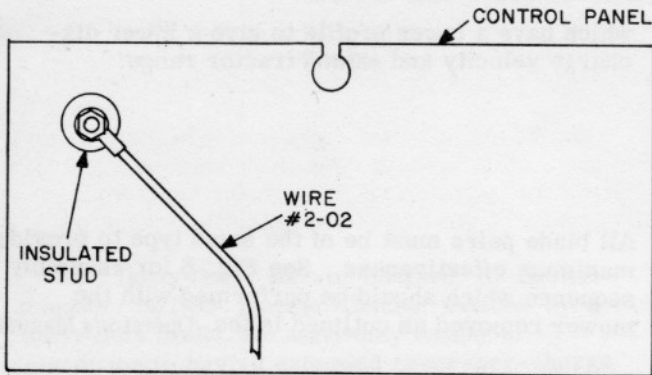

Figure 5A. Wire 2-02 Connection on Insulated Stud-Equipped Tractors

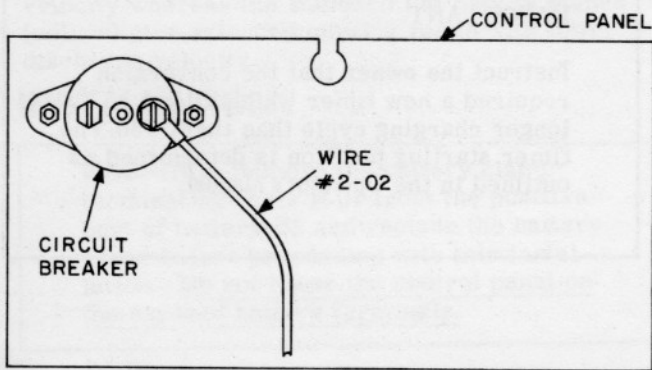

Figure 5B. Wire 2-02 Connection on Circuit Breaker-Equipped Tractors

13. Secure the cables to the front wall of the battery compartment with cable clips as indicated in Fig. 4.

14. Coat the battery terminals after connections are made with a thin film of Battery Terminal Protective Grease. Make sure all surfaces are coated!

15. Place the plastic cover over the batteries inside the top edges of the poly bag making sure the battery cables go through the end slots of the cover.

16. Remount the cross-bar over the rear compartment so the seat switch is towards the back of the tractor. Make sure wires numbered 10 and 12 are connected to the switch.

17. Attach a threaded "J-bolt" in the end hole of each hold-down angle clamp. Secure by installing a lockwasher and nut on the first few threads of each bolt.

18. Place the hold-down angle clamps along the sides of the battery cover, outside the top edges of the bag so the bag is between the cover and the clamps. Notice that there is a left and right clamp.

NOTE: Engage the front end of each hold-down in the corresponding slot in the front of the compartment and then lower the clamp into position. Allow the J-bolts to exit the rear of the compartment through the holes drilled in Step 1. Tighten the J-bolts to secure the batteries.

19. Replace the battery box cover and "H" plate over the shift lever.

20. Return the control panel to its original position, using care that wires do not get close to steering gears.

21. Clean each side of the front battery compartment in the area just below the EGT80 identification insignia. Remove the paper backing from the "Heavy Duty" plate and apply it as shown in Fig. 1.

22. Fill each new battery cell to the bottom of the filler opening with battery grade sulfuric acid of 1.260 specific gravity. Make sure all cells are filled to exactly the same level. This is important to ensure expected performance, since subsequent filling will be water addition only.

23. Plug in the power cord and set the timer to "Start" position "A". Batteries must complete a full charging cycle before being used.

NOTE: Allow one hour after the initial charging cycle is completed and check each cell for specific gravity. Readings should be uniform and at least 1.250 specific gravity when temperature corrected.

24. If it is desired to have a high velocity grass discharge, install the mower blades supplied with this kit. These blades are color coded black. The standard blades, supplied with EGT80 tractors are color coded yellow,

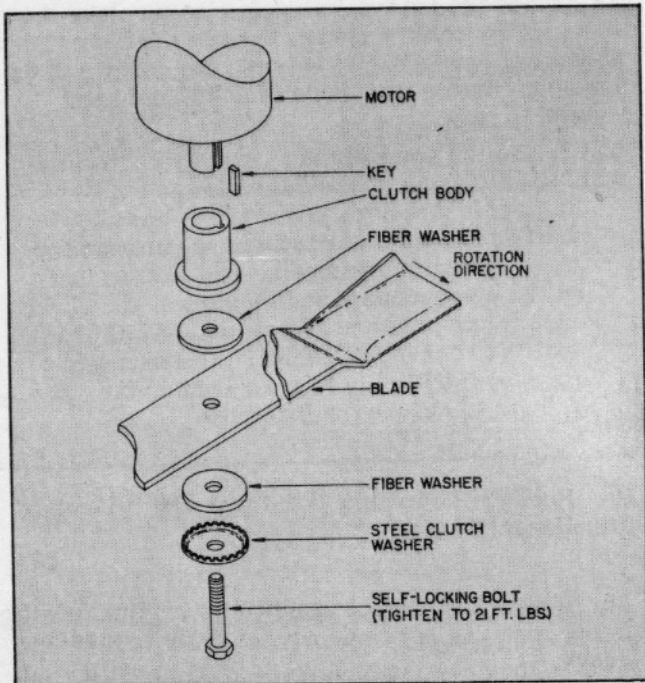

Figure 6. Blade Assembly Sequence

which have a lower profile to give a lower discharge velocity and extend tractor range.

All blade pairs must be of the same type to provide maximum effectiveness. See Fig. 6 for assembly sequence which should be performed with the mower removed as outlined in the Operator's Manual.

IMPORTANT

Instruct the owner that the conversion required a new timer which allows a longer charging cycle than the EGT80. The timer starting position is determined as outlined in the Operator's Manual.