

TRANSAXLE SHOP MANUAL

FOR

EGT80 - 8 H.P. CLASS TRACTOR

EGT100 - 10 H.P. CLASS TRACTOR

EGT120 - 14 H.P. CLASS TRACTOR

EGT150 - 16 H.P. CLASS TRACTOR

EGT200 - 18 H.P. CLASS TRACTOR

R36 RIDER MOWER

Battery power is better



PRINTED IN U.S.A.

SECTION I

GENERAL INFORMATION

IDENTIFICATION

All transaxles are similar in appearance. All have cast iron bodies for rugged usage; however, the physical size, speed ranges and components vary by tractor model and horsepower range.

Model Identification

EGT 80	Peerless model 1216 Transaxle
EGT 100	Peerless model 1216 Transaxle
EGT 120	Peerless model 1716 Transaxle
EGT 150	Peerless model 2318 Transaxle
EGT 200	Peerless model 2318 Transaxle
R-36	Peerless model 707 Transmission Peerless series 100 Differential

The axle support housings for the transaxle used in tractor models EGT 80 and EGT 100 are pressed through the case and cover. The housings cannot be removed without first disassembling the transaxle.

The axle support housings for the transaxle used in tractor models EGT 120, EGT 150 and EGT 200 are bolted to the case and cover and should be removed prior to the disassembly of the transmission.

The transaxle for the EGT 120 provides three speed ranges.

The transmission housing for the transaxles used in tractor models EGT 150 and EGT 200 is more massive than the housing used in the EGT 120 and has a larger machined area for the shifter assembly.

The transaxle used in tractor models EGT 150 and EGT 200 provides four speed ranges and is the only transaxle recommended for use with ground engaging tools.

The R-36 Riding Mower utilizes a differential chain driven from the transmission. The lawn and garden tractors utilize a unitized transaxle assembly which includes both a transmission and differential.

SECTION I

TRANSAXLE REMOVAL

1. If a malfunction is suspected in tractor drive components, check for the following before removing the transaxle assembly:
 - a) Loose or defective drive belt(s)
 - b) Improper sheave alignment
 - c) Loose or lost set screws in the driving or driven sheaves
 - d) Oil leaks which may have depleted the oil supply
 - e) Loose cap screws in axle support housing between case and cover, and in the shift lever mounting.
2. After correcting any and all of the above defects, test the unit for proper functioning of all drive components.
3. If the test indicates malfunctions within the transaxle assembly, remove the transaxle as follows:
 - a) Jack up tractor so that transaxle is accessible. Use wood blocks to prevent tractor movement. Do not use bricks, cement or cinder blocks.
 - b) Use a jack under the transaxle to support the transaxle as it is detached from the tractor frame.
 - c) If the rear of the tractor cannot be elevated sufficiently to allow clearance for the shifting lever as the transaxle is removed, remove the shifting lever.

EGT 80 AND 100 TRANSAXLE

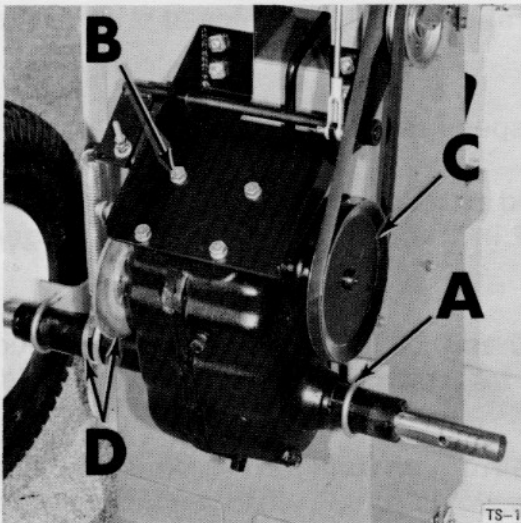

Figure 1

Fig. 1 - Remove the components and transaxle in the following sequence.

1. Drive wheels and belt shield
2. Drive belt and pulley "C"
3. Brake assembly and spring "D"
4. Four machine bolts at "B"
5. Wheel axle "U" clamps at "A" both sides.

SECTION I

6. With the transaxle free and supported on the jack, remove it from beneath the tractor and place it on a work bench.
7. Thoroughly clean transaxle before attempting any disassembly.

EGT 120 - 150 AND 200 TRANSAXLE

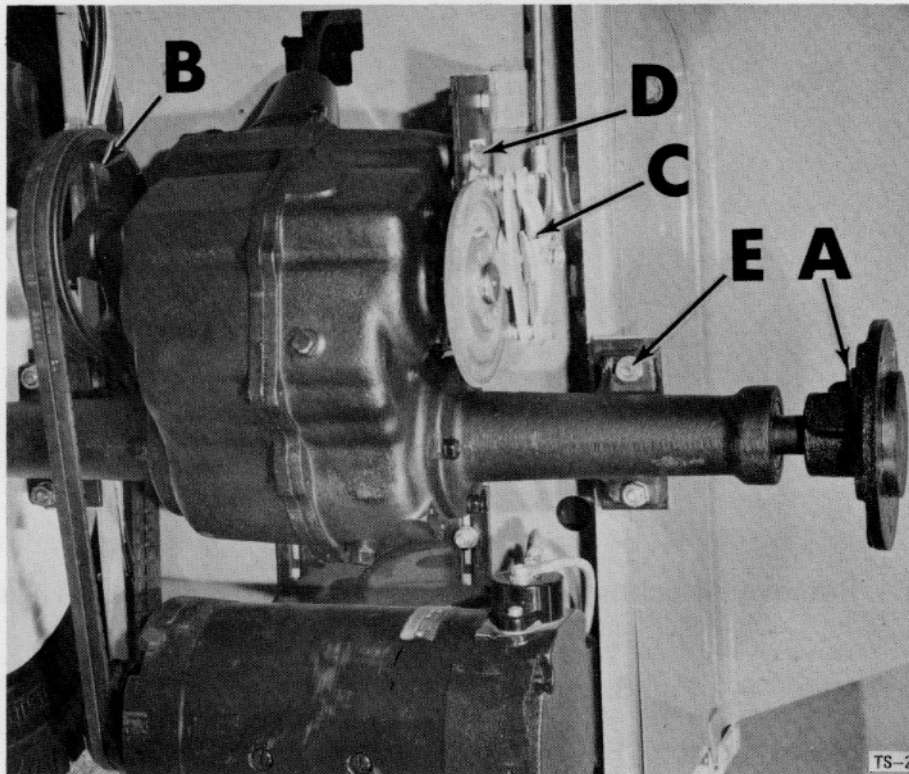

Figure 2

Fig. 2 - Remove attaching components and transaxle in the following sequence:

1. Drive wheels and drive hubs "A".
2. Drive belt and pulley "B".
3. Brake assembly "C".
4. Attaching bolt "D".
5. Axle bolts at "E" both sides.
6. With transaxle free and supported on jack, remove it from beneath the tractor and place it on a work bench.
7. Thoroughly clean transaxle before attempting any disassembly.

SECTION I

R-36 Rider - TRANSMISSION

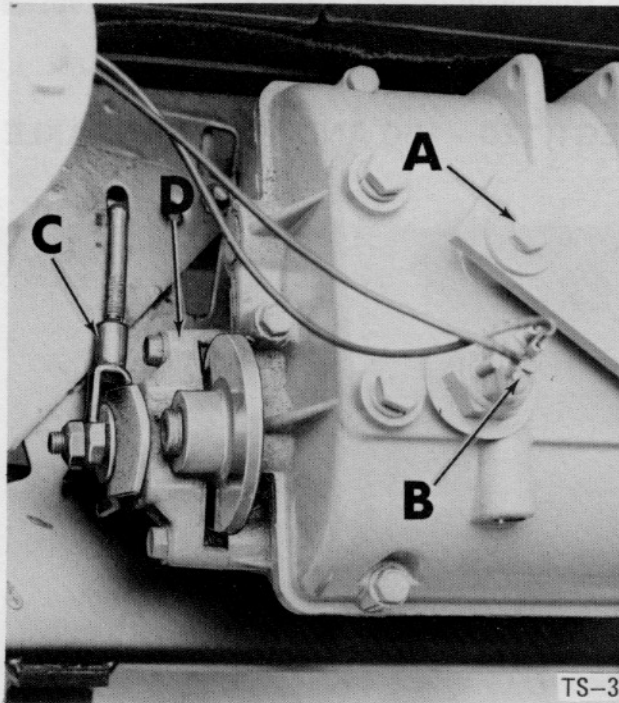

Figure 3

Figs. 3 & 4 - Remove attaching components and transmission in the following sequence:

1. Gear shift lever "A", Fig. 3.
2. Return to neutral switch "B", Fig. 3.
3. Yoke "C", Fig. 3, on clutch rod.
4. Loosen axle bolts "E", Fig. 4.
5. Drive chain "F", Fig. 4.
6. Drive belt, Fig. 4.
7. Loosen set screw on pulley "G", Fig. 4, remove pulley and key.
8. Four mounting bolts "H", Fig. 4.
9. Lift transmission assembly from frame and place on work bench.
10. Before disassembly of transmission, remove brake assembly "D", Fig. 3.
11. Thoroughly clean transmission before attempting any disassembly.

SECTION I

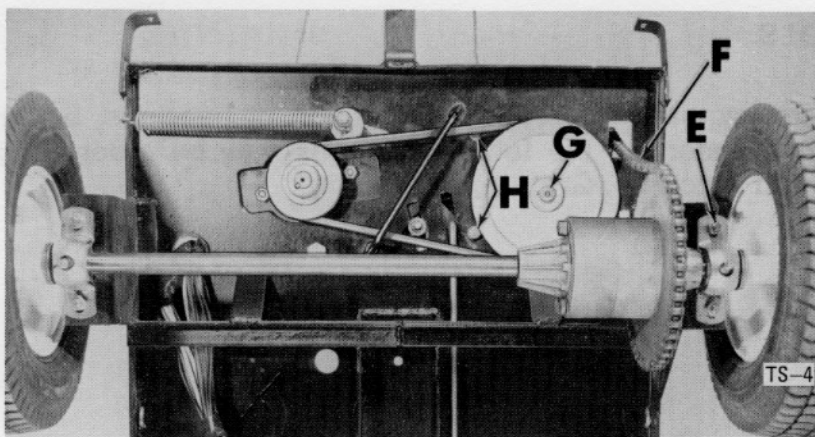

Figure 4

R-36 Rider - DIFFERENTIAL

Fig. 4 - Remove attaching components and differential in the following sequence:

1. Block up rear of Rider to obtain clearance beneath rear wheels for removal.
2. Remove snap ring on outer end of rear axle and remove wheel assemblies.
3. Loosen axle mounting bolt "E", Fig. 4 to loosen drive chain tension.
4. Remove drive chain "F", Fig. 4.
5. Remove axle mounting bolts "E", Fig. 4 (both sides) and lift differential from unit and place on work bench.
6. Slide bearings and bearing holders from axle shaft.
7. Thoroughly clean differential before attempting any disassembly.

SECTION I

SERVICE TOOLS

Special tools are required for proper installation of bearings, bushings, seals and gaskets. The tools listed on the following pages may be ordered by Part No. from Peerless Gear and Machine, Grafton, Wisconsin.

BEARING TOOL

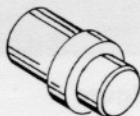

TS-5

Figure 5

- NO. 670170 - 1-1/8" - 1-3/8" Needle Bearing removal and installation. Used on all transaxles (Brake Shaft).
- NO. 670171 - 15/16" - 1-3/16" Needle Bearing removal and installation. Used on 2300 series transaxles (Output Shaft).
- NO. 670172 - 7/8" - 1-1/8" Needle Bearing removal and installation. Used on 2318 series transaxles (Brake Shaft).
- NO. 670173 - 1" - 1-1/4" Needle Bearing removal and installation. Used on 1716 and 2318 series transaxles (Brake Shaft).
- NO. 670174 - 1-3/4" - 2-1/8" Needle Bearing removal and installation. Used on 2318 series transaxles (Differential Carrier Bearing).
- NO. 60175 - 3/4" - 1" Needle Bearing removal and installation. Used on 1216 (Shifter Shaft, Idler Shaft, Brake Shaft and Output Shaft Bearings), 1716 (Shifter Shaft, Idler Shaft and Output Shaft) and 2318 (Input Shaft) Series Transaxles.
- NO. 670176 - 3/4" - 1-1/4" Needle Bearing removal and installation. Used on 1216 and 1716 (Input Shaft Needle Bearings) series transaxles.

SECTION I

BEARING TOOL



TS-6

Figure 6

NO.670194 - 7/16" Needle Bearing installation only. Used on all series transaxles (Shifter Shaft Pilot Bearing installation).

BURNISHING ROD AND BALL



TS-7

Figure 7

NO. 670177 - 3/8" Bushing sizing ball and driver. Used on 1216 and 1716 (Axle Bushing) and 2318 (Differential Carrier Bushing, 2 and 3 Gear Cluster).

NO. 670178 - 1" Bushing sizing ball and driver. Used on 1216 and 1716 (Outer Axle Bushing, Inner Axle Bushing) series transaxles.

BUSHING TOOL

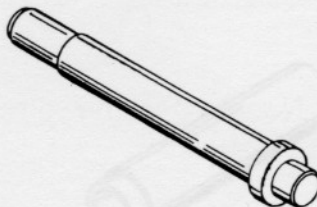

TS-8

Figure 8

NO.670181 - 1" - 1-1/8" Bushing removal and installation. Used on all series transaxles with 1" I.D. bushings.

NO.670183 - 7/8" Bushing removal and installation. Used on all series transaxles.

DRIVER

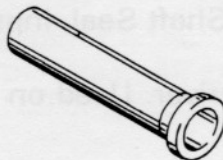

TS-9

Figure 9

NO.670227 - 1" Shaft. Used to drive ball bearings when restriction is at outer race. Used on transaxles.

NO.670220 - 7/8" Shaft. Used to drive ball bearings.

SECTION I

OIL SEAL SLEEVE

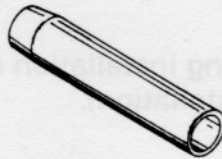

TS-10

Figure 10

NO. 670196 - 1.185" Seal Sleeve. Used on 1716 series transaxles.

NO. 670179 - 1" Seal Sleeve. Used on all series (Brake Shafts, Axles).

NO. 670182 - 3/4" Seal Sleeve. Used on all transaxles (Input Shaft Seal).

NO. 670185 - 7/8" Seal Sleeve. Used on all series (Brake Shaft and Axle Seals).

OIL SEAL DRIVER

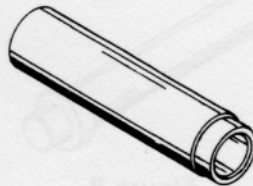

TS-11

Figure 11

NO. 670180 - 1" Seal Driver. Used on all transaxles (Axle Seals, Brake Shaft Seal).

NO. 670184 - Seal and Bearing Driver for 3/4" shafts. Used on 1216, 1716 (Input Shaft Seal) and 2318 (Input Shaft Seal, Input Bearing) series transaxles.

NO. 670186 - 7/8" Shaft Seal Driver. Used on all transaxles (Brakes Shaft, Axle Seals).

SECTION I

BEARING SUPPORT

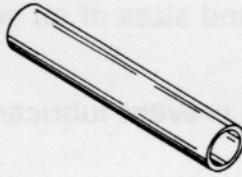

TS-12

Figure 12

NO. 670158 - 7/8" - Used to support and drive inner race of ball bearings when restriction is at inner race.

NO. 670162 - 1" - Used to support and drive inner race for all transaxle.

SECTION I

SEAL AND GASKET SERVICE

Transaxles contain various types and sizes of oil seals which may serve to:

- a) Seal inward (single lip) to prevent lubricant leaks.
- b) Seal outward (single lip) to prevent lubricant leaks.
- c) Seal both inward and outward (double lip).
- d) Gaskets have a sealant applied to either the case or cover sealing surface.

Some seals are spring loaded to ensure that the seal lip will make 100% contact around the shaft.

NOTE: Oil leakage may not always be caused by leaking seals, gaskets and "O" rings. Leakage can occur due to a cracked case or cover, flats on shafts, porosity (rarely, if ever) and worn bushings and shafts.

SEAL INSTALLATION

1. Check seal areas for evidence of oil leaks both at sealing surface and between metal-to-metal contact surface areas.
2. The surface over which the seal lips must slide must be free of all cuts, scratches, high spots or rust. The shafts should be smooth, shiny and a thin film of light oil applied.
3. When installing seals, the seals should be protected by the use of sleeves (see Service Tool-Fig 10) to clear keyways, splines or other sharp edges machined into shafts.
4. If removed, outward sealing seals (both single and double lips) must be replaced since there is no assurance that the initial sealing surface can be protected.

SECTION I

NEEDLE BEARING SERVICE

It is advisable to use an arbor press to remove and install needle bearings.

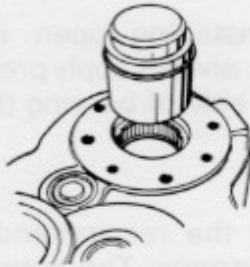

TS-13

Figure 13 - Bearing Remover End

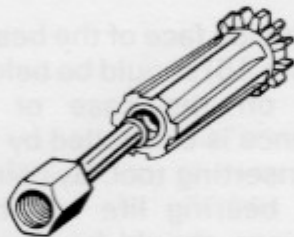

TS-16

Figure 16 - Blind Bearing & Puller



TS-17

Figure 17 - Removing Blind Bearing

Bearing Removal:

1. Use a bearing tool (Figure 13) to press out the bearing. Insert the proper tool in the bearing and with an arbor press, press out the bearing from the inside of the housing.
2. There are several methods to remove the needle bearing in the splined shifter shaft.
 - a) Use a blind bearing holder (not available from Peerless) as shown in Figs. 16 & 17.
 - b) Soak paper toweling or newspaper and tear in 1" to 2" squares.

Stuff these wet pieces of paper into the needle bearing until full. (Heavy fiber grease can also be used.)

Insert a 7/16" metal rod into bearing. With a mallet strike the rod sharply. This will compress the wet paper or fiber grease. Continue to add more wet paper or fiber grease to keep the bearing opening full. This will hydraulically lift the bearing out of the shaft.

SECTION I

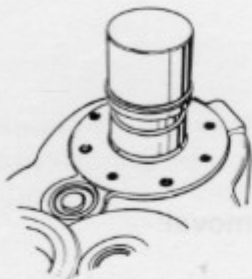

TS-14

Figure 14 - Bearing Installer End.

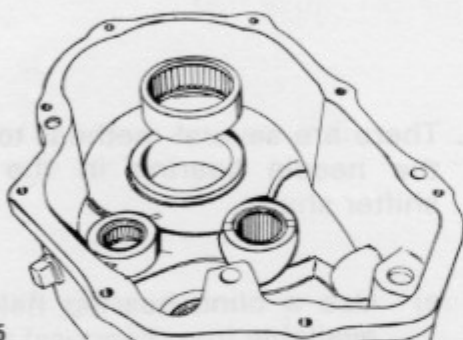

TS-15

Figure 15 - Bearing Surfaces

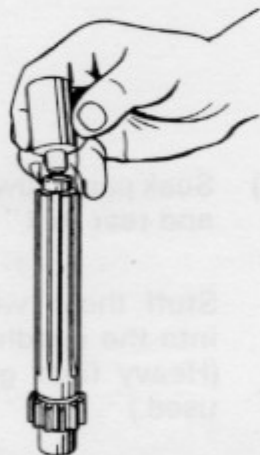

TS-18

Figure 18 - Installing Blind Bearing

Bearing Installation:

3. When installing open end needle bearings, always apply pressure to the stamped side of bearing (Figure 14).
4. Use only the recommended tools to insert bearings. The opposite end of the bearing removal tool is used for replacement.
5. The inside face of the bearing housing (Figure 15) should be below the thrust face on the case or cover. This distance is controlled by the design of the inserting tool. By using the proper tool, bearing life will be extended. Bearings should be pressed into the case or cover .015 or .020 below the thrust surface. The open end bearing in the low speed shaft ear of four-speed transaxles is to be .010 below the thrust surface. The open end bearing in the shifter shaft should be .010 below the bearing surface.
6. Use the recommended tool, Fig. 18, to install the new bearing. Needle bearings in shifter shaft should be installed .010 below bearing surface.

Figure 18 - Installing Blind Bearing

SECTION I

GENERAL BEARING AND BUSHING CARE

1. Bearings, bushings and bearing surfaces should be thoroughly cleaned prior to examination. Examine closely for scuffing, wear, pitting and abnormal conditions. Replace bearings and bushings if any abnormal conditions are found.
2. Use a good grade of clean solvent to clean bearings. After cleaning, always use clean lint-free cloth to dry and wipe bearings. Immediately coat cleaned bearing with lubricant to prevent rusting or corrosion. If the bearing is to be stored, wrap in oil-proof paper until needed. Ball bearings will be damaged if spun with compressed air. Moisture from compressed air will cause rust.
3. When disassembling transaxle components protect the bearings in the case and cover from foreign matter by placing the case and cover gasket surface down on clean paper and cover with a clean cloth.

Never clean the lubricant from new bearings. This lubricant prevents damage before the transaxle lubricant enters the bearing.

BALL BEARING SERVICE

Sealed ball bearings are used in the outer ends of the axle supports. To check these bearings, remove the axle and rotate the inner race with the fingers. If any roughness is noted, replace the ball bearing assembly. These ball bearings are factory lubricated and additional lubricants cannot be added. When installing ball bearings, use the proper tool that drives on the outer race.

Install the needle and ball bearing combination into the case and cover prior to installing other parts. Bearings are to be installed .015 to .020 below thrust surface.

SECTION I

BUSHING SERVICE

When removing bushings, use the combined bushing remover and installation tool. Position the assembly to be serviced on the table of an arbor press, allow an opening for the bushing to pass through.

1. The bushings in the three gear cluster (four-speed transaxle) are both removed at the same time. The bushing from one end will contact the bushing in the opposite end of the three gear cluster housing and be forced out at the same time.
2. After new bushings are pressed into the assembly, they must be sized. To size the bushings, use an arbor press to push the proper steel ball through the bushing. See the SPECIAL TOOL LIST for selecting the proper sizing ball and driver.

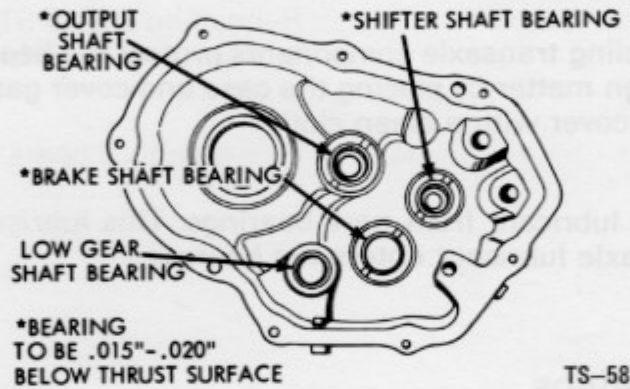

Figure 18 A - Cover Assembly

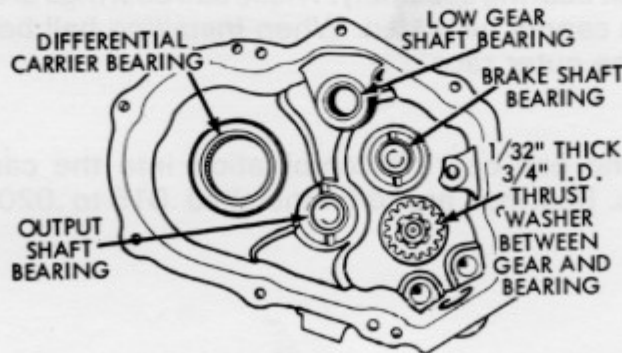

Figure 18 B - Case Assembly

SECTION I

PROBLEM IDENTIFICATION

PROBLEM - UNIT CANNOT BE SHIFTED (OR DIFFICULT TO SHIFT)

CAUSE	REMEDY
Gears improperly installed.	Review positioning of gears.
Forks and rod assembly incorrectly installed.	Remove assembly. Recheck and correctly position parts.
Axle housing will not seal properly.	Reseat seal retainers in axle housing.
Shifting lever improperly positioned.	Reposition shift lever, using required gasket under shift lever housing.
Shift lever housing misaligned to case.	Realign shift lever housing.
Shifter stop assembled incorrectly.	Reposition shifter STOP so that the notch is aligned with shifter forks in NEUTRAL position.
Chamfer on shift gears on wrong side.	Reassemble gears. See ASSEMBLY section for instructions.

SECTION I

PROBLEM - UNIT IS NOISY

CAUSE	REMEDY
Gears overly noisy - chatter, etc.	1. Transaxle fluid low. 2. Gears not meshed properly.
Metallic pieces and/or other foreign objects in transaxle.	Disassemble transaxle assembly; thoroughly clean parts and housing; replace parts as required.
Worn gears.	Remove and replace with new gears.
Worn bearings - mainly input shaft ball bearing.	Replace bearing.

PROBLEM - UNIT JUMPS OUT OF GEAR

CAUSE	REMEDY
Shifting lever improperly assembled in housing.	Remove shifting lever and properly assemble.
Teeth of gears are worn beyond tolerances.	Replace worn gears.
Spring in shifter fork weak or broken.	Replace spring.
Attaching screws for shift lever and housing assembly not properly torqued.	Torque screws to 10 ft. lbs.
Shift lever bent and hitting unit frame.	Replace shift lever.
Shift rod grooves worn.	Replace shift rods.
Constant mesh gears improperly installed on countershaft.	Reposition gears.
Ball indent spring broken.	Replace spring.

SECTION I

PROBLEM - AXLES CANNOT BE TURNED (SAME DIRECTION) WITH UNIT IN NEUTRAL GEAR

CAUSE	REMEDY
Axle binding in axle support housing.	Seal retainers are not properly seated. Tighten axle housing bolts.
Burrs on gears.	Remove gear and hone with a stone.
Parts missing.	Install missing parts.
Shifter rod snap rings out of groove.	Replace snap rings on shift rod.
Broken shifter stop allowing unit to be shifted into two speeds at the same time.	Replace shifter stop.
Thrust washers in wrong position.	Reposition thrust washers.
Bearings not seated properly in case or cover.	Use the proper bearing tool and seat bearings properly.
Improper mating of case to cover.	Dowel pins not installed.
Thrust washers improperly installed.	See ASSEMBLY section for instructions.
Gears improperly installed.	Correct assembly of parts required.
Input shaft not properly installed	Input shaft spline must be fitted into gear and must be seated into the case.
Differential reversed in installation.	Correct installation of differential.

SECTION I

TORQUE VALUES

Be sure to torque all bolts and cap screws to the recommended torque values. The torque specifications are included in the assembly instructions.

1. Overtightening - Can strip threads, compress the gasket excessively, possibly causing binding.
2. Undertightening - Causes oil leakage, loosening of attaching parts, possible shifting of internal parts which can cause a complete failure of transaxle.
3. Cross tightening sequence in two stages must be used when torquing case to cover cap screws.
4. Always use a torque wrench for accurate results.

TORQUE VALUES

Part	Models	Ft. Lbs.
1/4-20 Bolt Case to Cover	ALL	8-10
1/4-20 Bolt Differential	ALL	7-10
1/4-20 Bolt Shift Lever Housing	EGT 80 & 100	7-9
1/4-20 Bolt Shift Lever Housing	EGT 120, 150, 200	7-10
5/16-18 Bolt Differential	EGT 80 & 100	19-22
5/16-18 Nut Differential	EGT 80 & 100	10-13
5/16-18 Bolt Axle Support Housing	EGT 120	13
5/16-18 Bolt Axle Support Housing	EGT 150 & 200	15-18
3/8-16 Bolt Axle Support Housing	EGT 200	20-26

SECTION I

TESTING

After the transaxle has been reassembled and oil added, the following testing procedure should be performed:

1. Check for oil leaks.
2. With the shifter forks in neutral, rotate both axle shafts in the same direction. Both axle shafts should turn smoothly (no binding).
3. With the axle shafts rotating together, the brake shaft should rotate, but the input shaft should not be rotating.
4. By moving shifter fork into any gear position, a greater drag should be felt on axle shafts.

Cause of binding within transaxle:

1. Reused or lack of gaskets
2. Improper mesh of gears
3. Input shaft not completely seated in case
4. Misalignment of case and cover (dowel pin not installed)
5. Improper installation of the following:

Oil seal retainers
Thrust washers, bearings and spacers
Shifter assembly parts
Differential in backward

SECTION I

RANGE SELECTOR and SHIFTING SERVICE

SHIFT LEVER ASSEMBLY

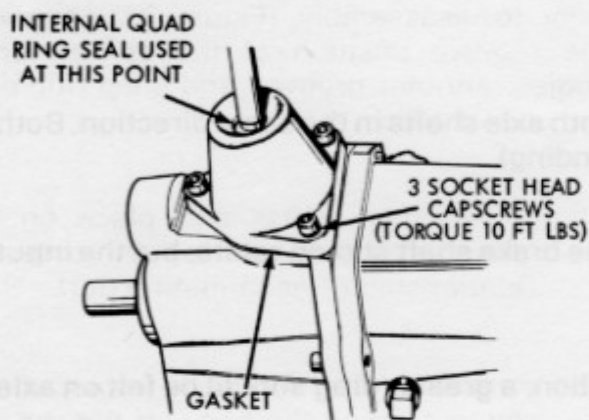

TS-19

Figure 19 - Shift Lever Housing

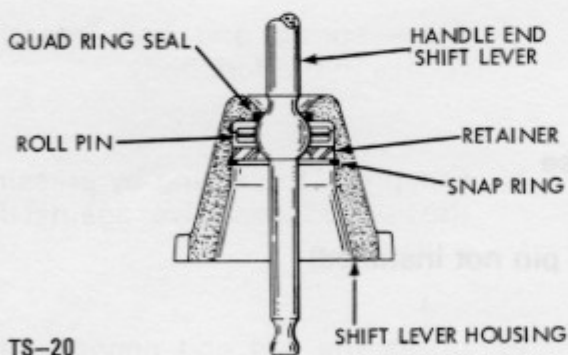

Figure 20 - Snap Ring Type Shift Lever

DISASSEMBLY

Prior to removing shifter assembly from a transaxle (Figure 19) note the position of the lever in the housing to assure correct reassembly.

1. Clamp the shift lever handle in a vise with the housing 1" or more above the vise jaws.
2. Remove the snap ring (Figure 20) and slide housing downward and off the shaft. Remove the retainer and roll pin from the lever housing. Check retainer, seal and roll pin, replace if damaged.

NOTE: If oil leaks from shift lever housing, the quad ring seal must be replaced.

ASSEMBLY

Replace bent or worn roll pin and assemble in the reverse order of disassembly. Be sure the lever is in correct relationship to the housing before installing roll pin.

SECTION I

SHIFTING ASSEMBLY

If any of the shifting assembly parts are damaged or show excessive wear and need replacing, proceed as follows:

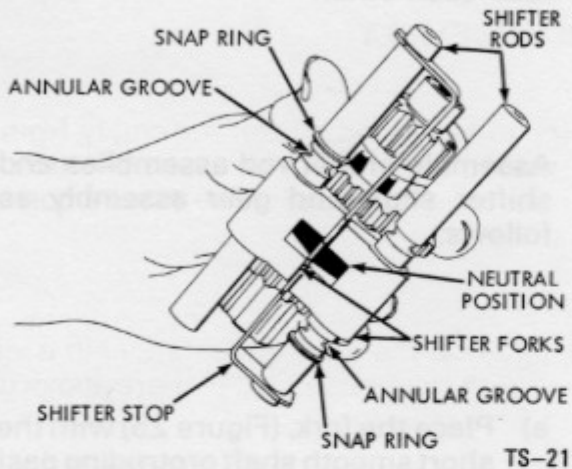

Figure 21 - Shifter Assembly

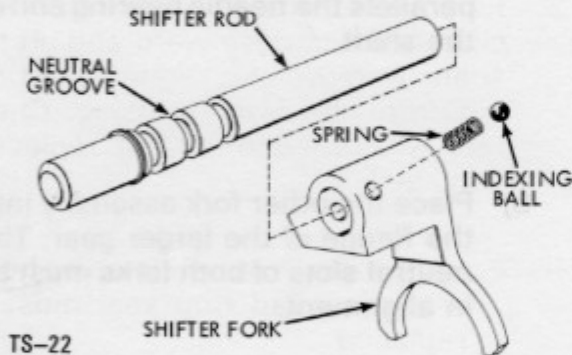

Figure 22 - Assemble Shifter Forks to Shifter Rods

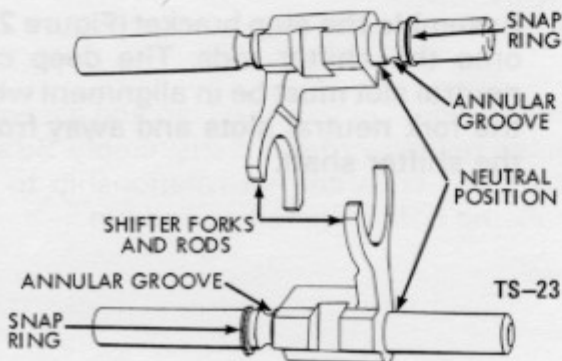

Figure 23 - Shifter Forks and Rods Positioned In Neutral

DISASSEMBLY

Prior to disassembly, (Figure 21) observe the relative position of the shifter fork bodies, annular grooves and snap ring on the shifter rods.

1. Disassemble parts and place on a clean shop towel in an orderly relationship of each mating part.
2. Remove shifter fork body from shifter rod by tapping the body off the rod.

ASSEMBLY

1. Assemble the shifter rods and shifter fork bodies as follows: (Figures 22 & 23)
 - a) Place spring and ball into the recess in the fork body.
 - b) Compress the spring by pressing the tip of a screw driver against the ball.
 - c) Insert the rod end opposite the snap ring into the ball end of the fork body.
 - d) Move the fork body to position the ball in the neutral (2nd) annular groove.

SECTION I

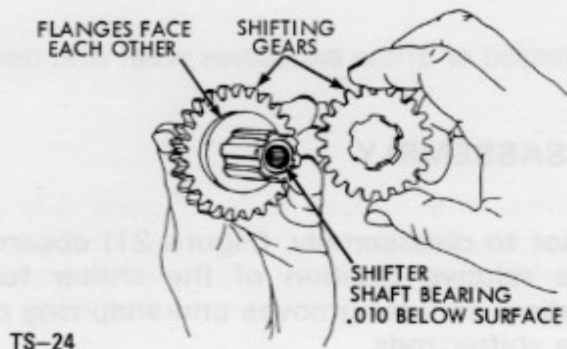

Figure 24 - Two Flanged Gears onto Shifter Shaft

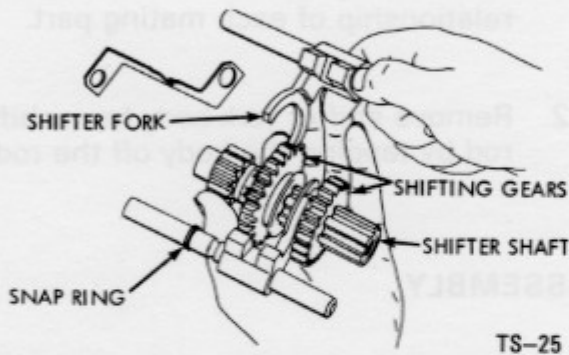

Figure 25 - Assembling Shift Fork, Gears and Shaft Assemblies

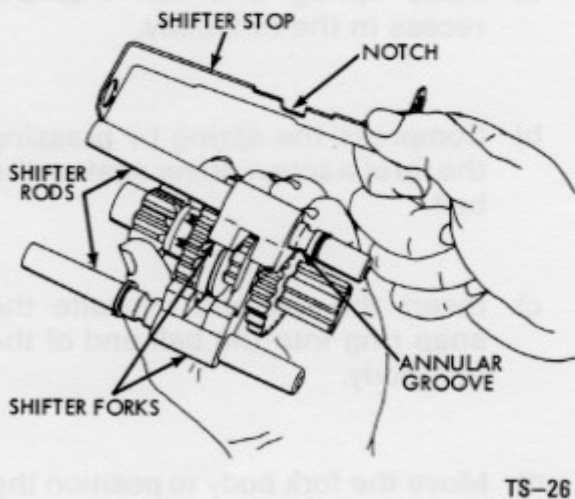

Figure 26 - Positioning Shifter Stop

2. Assemble the shifter shaft (Figure 24) by inserting the needle bearing end through first the larger gear then the smaller gear. The fork flanges must face each other.

3. Assemble shifter rod assemblies and shifter shaft and gear assembly as follows:

a) Place the fork, (Figure 25) with the short smooth shaft protruding past the fork, into the flange of the smaller gear. The short rod end parallels the needle bearing end of the shaft.

b) Place the other fork assembly into the flange of the larger gear. The neutral slots of both forks must be in alignment.

4. Assemble the stop bracket (Figure 26) onto the shifter rods. The deep cut neutral slot must be in alignment with the fork neutral slots and away from the shifter shaft.

SECTION I

SHIFTING ASSEMBLY

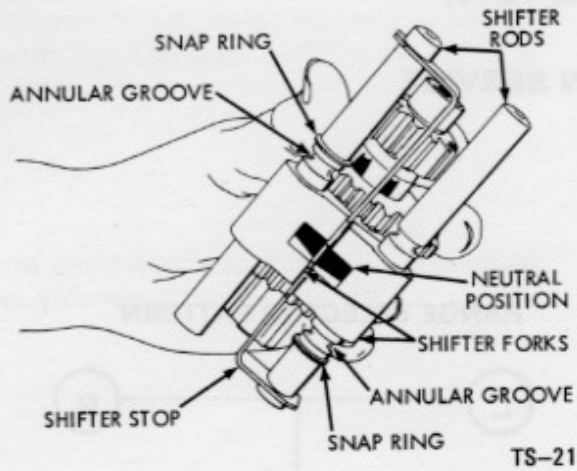

When the shifter forks (Figure 27) are properly positioned for final assembly, both shifter rods in neutral will have one annular groove exposed between the fork body and the snap ring.

Figure 27 - Final Assembly

SECTION II

TRANSAXLE SERVICE EGT 80 and EGT 100 (Peerless Model 1216)

TRANSMISSION SERVICE

IDENTIFICATION

TRANSAXLE

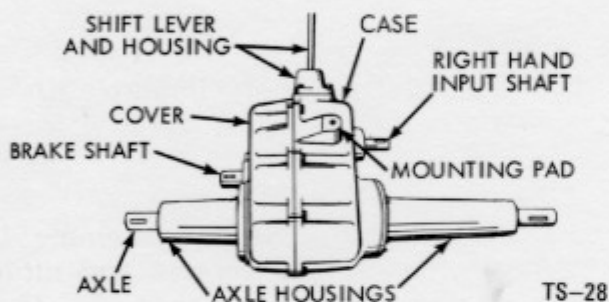
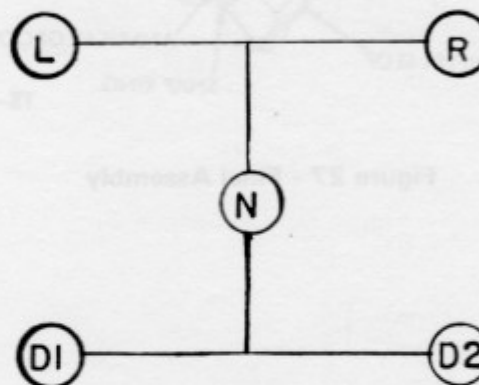

Figure 28

RANGE SELECTOR PATTERN



TS-29

Figure 29

The transmission of the transaxle used in Avco New Idea electric garden tractor Models EGT 80 and EGT 100 provides three forward and one reverse speed ranges.

The axle support housing is pressed through the case and cover requiring the disassembly of the transmission to service the support housing bushings.

SECTION II

TRANSAXLE

DISASSEMBLY

Inspect transaxle and follow removal procedures outlined in "Transaxle Removal Procedures" on Page 2 of Section I. After removal of transaxle, proceed as follows:

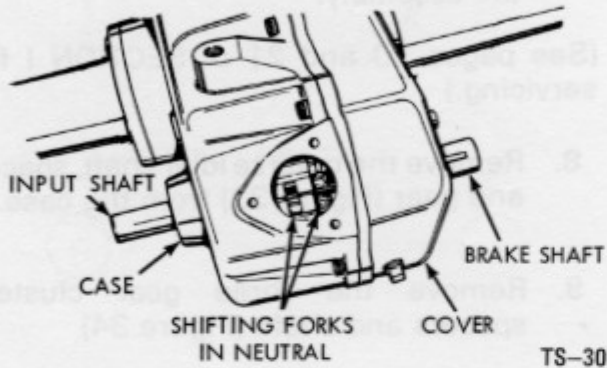

Figure 30 - Transaxle Case

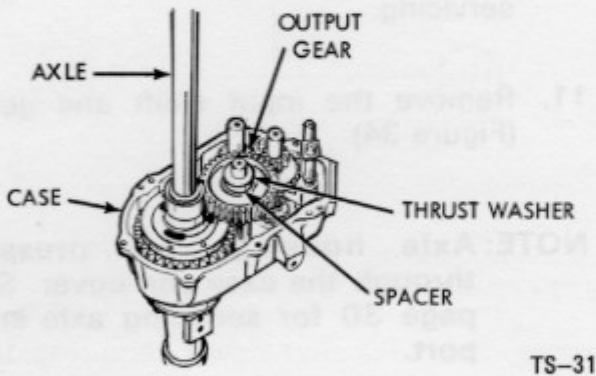

Figure 31 - Output Gear and Shaft

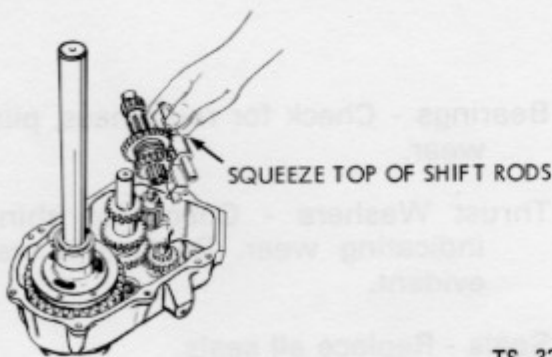

Figure 32 - Removing Shifting Assembly

1. Clean transaxle thoroughly and remove all paint, rust and scratches from exposed ends of axles prior to disassembly.
2. Place shifter shaft (Figure 30) in neutral.
3. Remove shifter lever assembly by removing (3) cap screws and lifting assembly from the transaxle. (See Page 20 of SECTION I for servicing.)
4. Position the transaxle assembly on a disassembly stand with case half downward.
5. Drive dowel pins (2) into the case, remove socket head cap screws and lift the cover from the case. Discard gasket.

NOTE: The brake shaft and spur gear remain with the cover.

6. Remove washer, spacer, spur gear and output shaft, (Figure 31) from case.

SECTION II

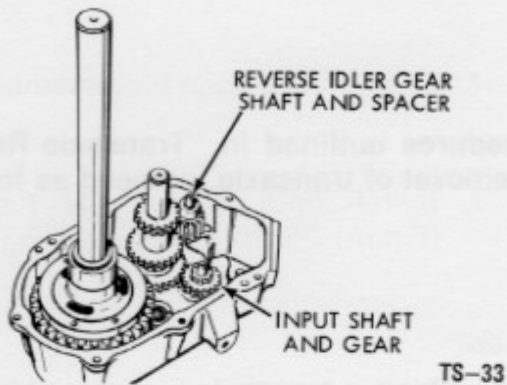

Figure 33 - Reverse Idler Gear and Shaft

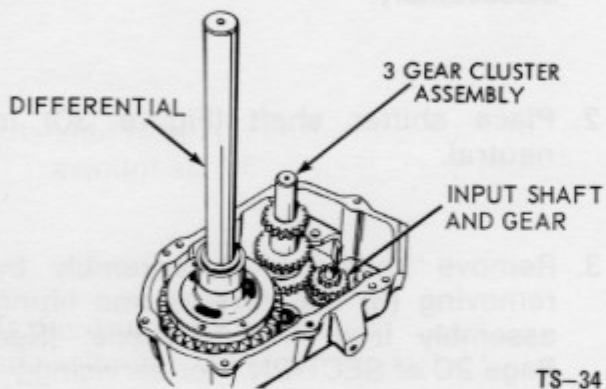

Figure 34 - Three Gear Cluster

7. Remove the shifting assembly (Figure 32) by squeezing the ends of the shift rods together. Lift out the assembly as a unit. Prior to removal, note the position of the shifter fork and annular grooves to facilitate reinstallation of the assembly.

(See pages 20 and 21 of SECTION I for servicing.)

8. Remove the reverse idler shaft, spacer and gear (Figure 33) from the case.
9. Remove the three gear cluster, spacers and shaft. (Figure 34)
10. Remove the differential and axle assembly. (Figure 34) See page 29 for servicing.
11. Remove the input shaft and gear. (Figure 34)

NOTE: Axle housings are pressed through the case and cover. See page 30 for servicing axle support.

INSPECTION AND REPAIR

Gears - Check bevels for galling caused by improper shifting.

Shafts - Check for rust, pitting, scratches or wear.

Case and Cover - Check for cracks, stripped threads and uneven sealing surfaces.

Bearings - Check for roughness, pits and wear.

Thrust Washers - Check for shininess indicating wear. Replace if wear is evident.

Seals - Replace all seals.

SECTION II

ASSEMBLY

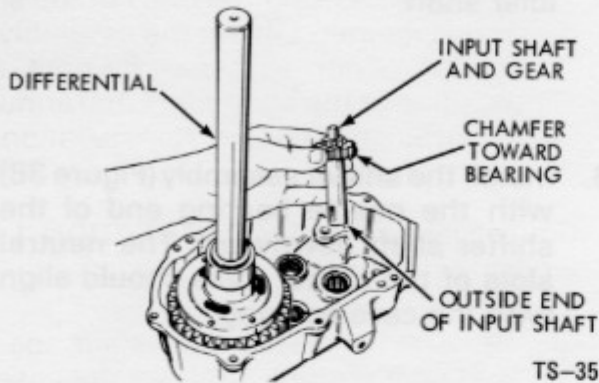

Figure 35 - Input Shaft and Gear

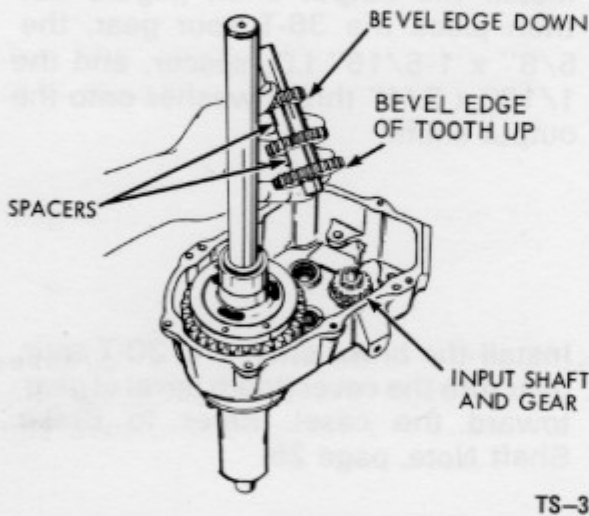

Figure 36 - Install Three Gear Cluster

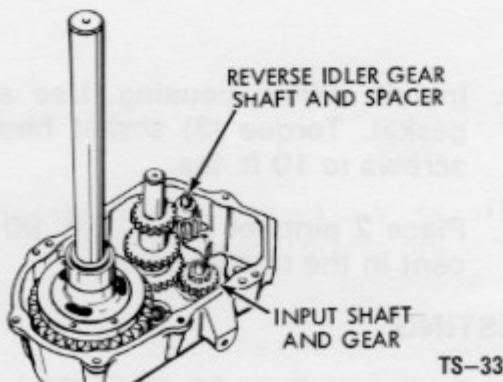

Figure 37 - Reverse Idler Gear and Shaft

1. Position the case for assembly.
2. Install input shaft and 16-T spur gear (Figure 35) into the case.
3. Install the differential assembly (Figure 35) with the differential bolt heads down and the short axle shaft through the case.
4. Install the three gear cluster idler shaft and gears (Figure 36) as follows:
 - a) Place the 26-T spur gear (with the tooth bevel up) over the idler shaft bearing in the case.
 - b) Insert the idler shaft through the gear and into the bearing.
 - c) Install the 3/4" x 7/8" I.D. spacer on the idler shaft.
 - d) And, install the 22-T spur gear on the shaft with the tooth bevel down.
 - e) Install the 1-1/4" x 7/8" I.D. spacer on the shaft.
 - f) Then, place the 16-T spur gear on the shaft with the tooth bevel down toward the case.
 - g) Place thrust washer on end of shaft.

SECTION II

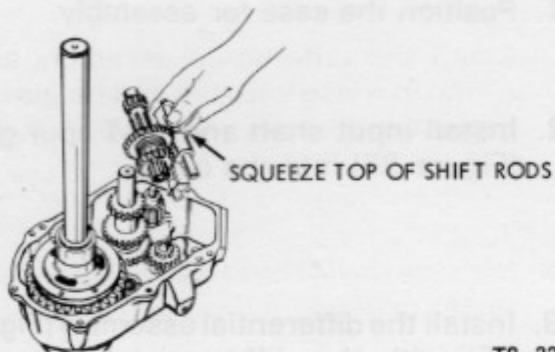

Figure 38 - Install Shifter Assembly

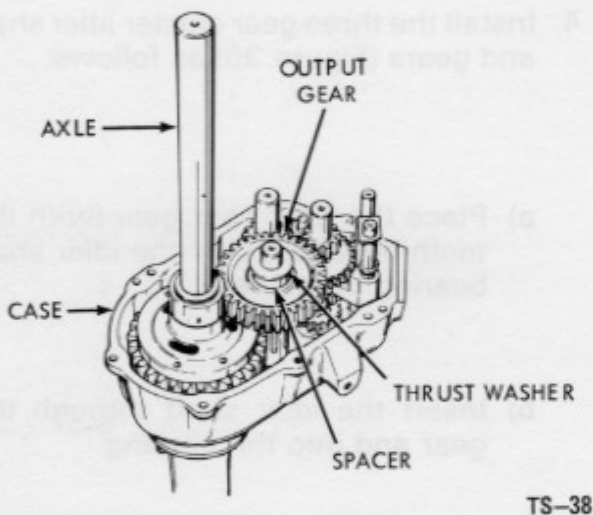

Figure 39 - Output Gear and Shaft

5. Place the reverse idler shaft (Figure 37) in the case, then install the 22-T spur gear (tooth bevel up) and the 1/2" x 1/2" I.D. spacer on the reverse idler shaft.
6. Install the shifter assembly (Figure 38) with the needle bearing end of the shifter shaft downward. The neutral slots of the shifter forks should align with the case opening.
7. Install the output shaft (Figure 39) then place the 36-T spur gear, the 5/8" x 1-5/16" I.D. spacer, and the 1/16" x 3/4" thrust washer onto the output shaft.
8. Install the brake shaft and 30-T spur gear into the cover (tooth bevel of gear toward the case). Refer to Brake Shaft Note, page 25.
9. Install the cover as follows:
 - a) Align a new gasket on the seal surface of the case.
 - b) Position the cover on the case.
 - c) Align the case and cover with (2) dowel pins.
 - d) Secure case to cover with (8) 1/4-20 x 3/4" socket head cap screws. Torque to 10 ft. lbs.
10. Install shifter housing. Use a new gasket. Torque (3) socket head cap screws to 10 ft. lbs.
11. Place 2 pints of S.A.E. E.P. 90 lubricant in the transmission.

TESTING

See Testing on Page 19, SECTION I, of this manual.

SECTION II

DIFFERENTIAL SERVICE

DISASSEMBLY

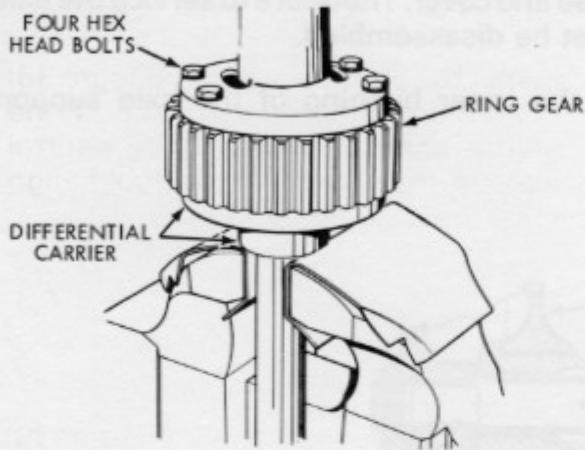

TS-39

Figure 40 - Differential Bolt Removal

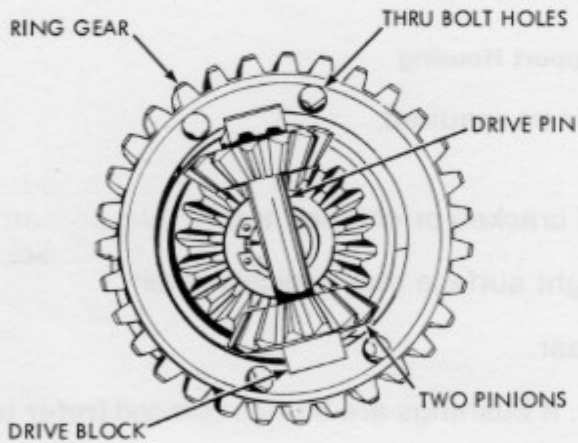

TS-40

Figure 41 - Differential Assembly (One Carrier Removed)

1. Clean the differential assembly and clamp in a vise with the bolt heads up. Protect shaft from vise jaws.
2. Remove the (4) hex head bolts and the upper axle and differential carrier.
3. Lift drive pin, drive blocks, and pinion gears from inside of ring gear.
4. Remove ring gear.
5. Remove snap ring and bevel gear from each axle.
6. Slide the differential carrier from the axles.
7. Remove (2) thrust washers from each axle.

SECTION II

DIFFERENTIAL SERVICE

INSPECTION AND REPAIR

The axle housings are pressed through the case and cover. Therefore to service the axle housing bushings or seals the transaxle must be disassembled.

The differential assembly is supported on the inner bushing of the axle support housing.

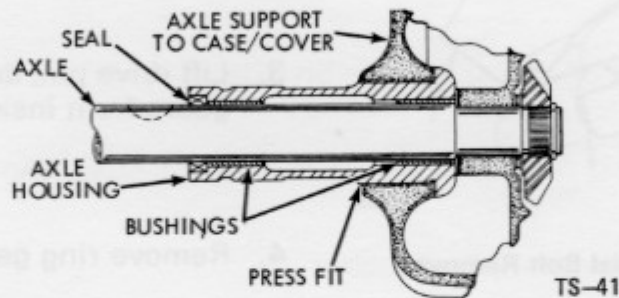

Figure 42 - Axle Support Housing

Inspect the following items. Replace or repair as required.

Gears and Pinions - Check for wear and cracked or chipped teeth.

Thrust Washers - Check for wear. A bright surface may indicate wear.

Drive pin and Drive Block - Check for wear.

Axle housing bushings - Check for wear. If bushings are being replaced (refer to Bushing Care - Section I - Page 14).

NOTE: The seals at the outer end of the axle housing should be replaced after assembly is completed.

SECTION II

DIFFERENTIAL SERVICE

ASSEMBLY

1. Clamp axle in a vise with the splined end up, oil all parts and assemble as follows:
 - a) Place (2) 1/32" x 7/8" thrust washers on the axle.
 - b) Install differential carrier on axle.
 - c) Place 1/8" x 7/8" thrust washer on axle.
 - d) Install bevel gear on axle and secure with the snap ring.
2. Assemble other axle as outlined above.
3. Clamp the axle assembly with the threaded differential carrier in the vise.
4. Place the ring gear on the carrier.
5. Assemble the drive pin, drive blocks and pinion gears into the ring gear.
6. Install the other axle, align the bolt holes, and secure differential with (4) 1/4-20 x 2-1/4" Grade 8 hex head cap screws. Torque to 7 ft. lbs.

TESTING

Test differential action by holding the upper axle vertically, and spinning the differential. The unit should spin and rotate freely. Place the assembly on the bench and rotate both axles in opposite directions. If any binding is noted in either test, check retaining bolt torque, gear meshing and/or bearing surfaces in the differential carriers. Little or no end-play should be apparent between the axles and carriers.

SECTION III

TRANSAXLE SERVICE EGT 120 (Peerless Model 1716)

TRANSMISSION SERVICE

IDENTIFICATION

TRANSAXLE

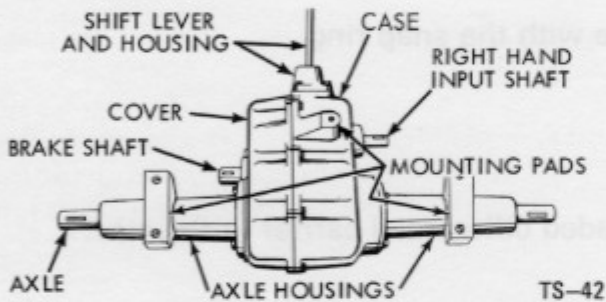

Figure 43

RANGE SELECTOR PATTERN

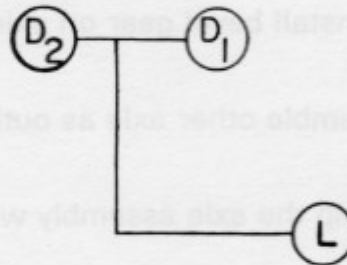

Figure 44

The transmission of the transaxle used in Avco New Idea electric garden tractor model EGT 120 provides three speed range selections (no reverse gear).

Forward and reverse ground speeds in any given transmission range are selected by the operator through an electric speed control.

SECTION III

TRANSAXLE

DISASSEMBLY

Inspect transaxle and follow removal procedure outlined in "Transaxle Removal Procedures" on Page 3 of Section I. After removal of transaxle, proceed as follows:

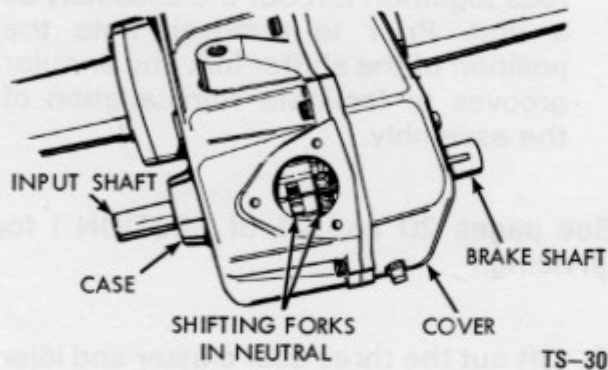

Figure 45 - Transaxle Case

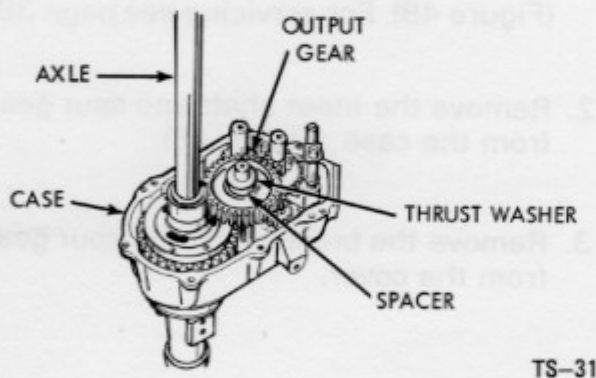

Figure 46 - Output Gear and Shaft

1. Clean transaxle thoroughly and remove all paint, rust and scratches from exposed ends of axles prior to disassembly.
2. Remove axle shaft housings by removing attaching bolt and slide the housing off the axle shafts. For servicing see page 39.
3. Place shifter lever (Figure 45) in neutral.
4. Remove shifter lever assembly by removing (3) cap screws and lifting assembly from the transaxle. (See page 20 of SECTION I for servicing.)
5. Remove (8) retaining cap screws from the case and cover.
6. Position the transaxle assembly on a disassembly stand with case half downward.
7. Drive dowel pins (2) through the cover into the case and lift the cover from the case.

SECTION III

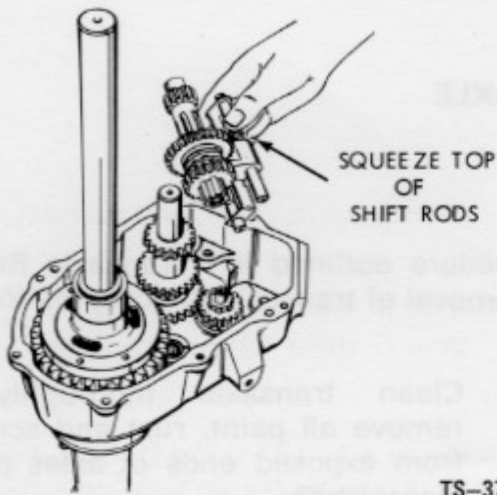

Figure 47 - Removing Shifting Assembly

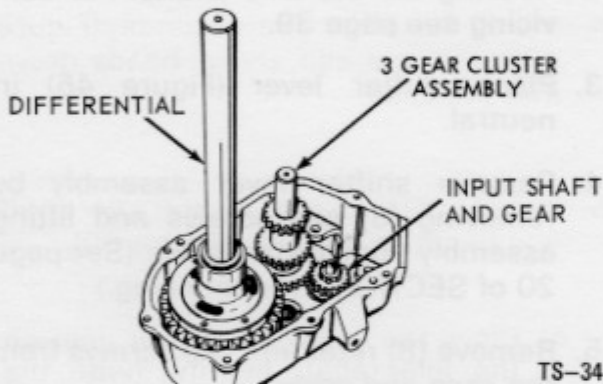

Figure 48 - Three Gear Cluster

NOTE: The brake shaft and idler gear remain with the cover.

8. Remove washer, spacer spur gear and output shaft (Figure 46) from case.
9. Remove the shifting assembly (Figure 47) by squeezing the ends of the shift rods together. Lift out the assembly as a unit. Prior to removal, note the position of the shifter fork and annular grooves to facilitate reinstallation of the assembly.

(See pages 20 and 21 of SECTION I for servicing.)

10. Lift out the three gear cluster and idler shaft assembly. (Figure 48)
11. Remove the differential assembly (Figure 48). For servicing see page 38.
12. Remove the input shaft and spur gear from the case. (Figure 48)
13. Remove the brake shaft and spur gear from the cover.

INSPECTION AND REPAIR

Gears - Check bevels for indication of galling caused by improper shifting.

Shafts - Check for rust, pitting, scratches or wear.

Case and Cover - Check for cracks, stripped threads and flat sealing surfaces.

Bearings - Check for roughness, pits and wear.

Thrust Washers - Check for shininess, indicating wear. Replace if wear is evident.

Seals - Replace all seals.

SECTION III

ASSEMBLY

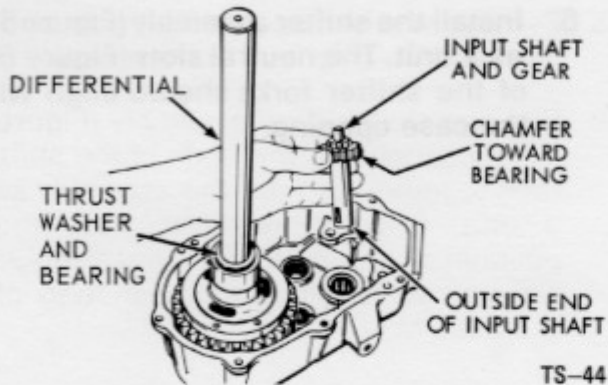

Figure 49 - Input Shaft and Gear

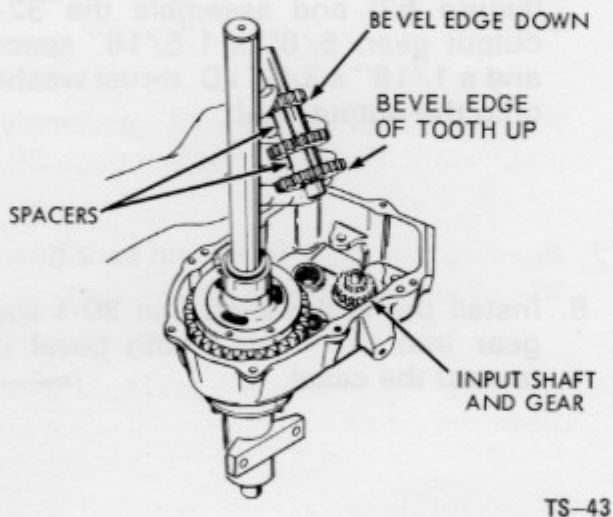

Figure 50 - Install Three Gear Cluster

1. Position the case for assembly.
2. Install the input shaft and 16-T spur gear (Figure 49) into the case.
3. Place a $1/16''$ x $1''$ I.D. thrust washer, then a roller thrust bearing followed by a $1/16''$ x $1''$ I.D. thrust washer (Fig. 49) on the axle shaft.
4. Install the differential assembly (Figure 49) with the cap screw heads down into the case.
5. Install the three gear cluster idler shaft and gears as follows: (Figure 50)
 - a) Place the larger 26-T spur gear on the idler shaft bearing (with the tooth bevel up).
 - b) Insert the idler shaft through the 26-T spur gear and into the bearing.
 - c) Install the $25/32''$ x $7/8''$ I.D. spacer onto the idler shaft.
 - d) Install the 22-T spur gear onto the idler shaft with the bevel down toward the larger gear.
 - e) Install the $1-3/16''$ x $7/8''$ I.D. spacer onto the idler shaft.
 - f) Install the smaller 16-T spur gear onto the idler shaft with the tooth bevel down toward the case.

SECTION III

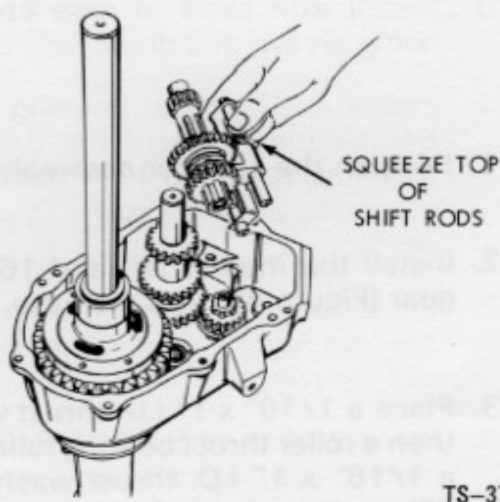

Figure 51 - Install Shifter Assembly

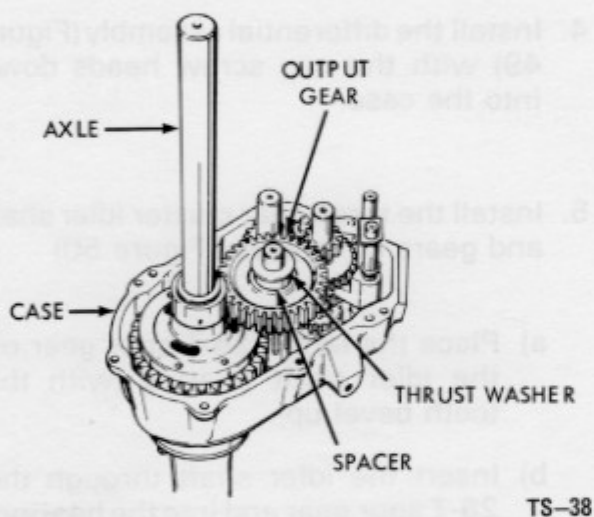

Figure 52 - Output Gear and Shaft

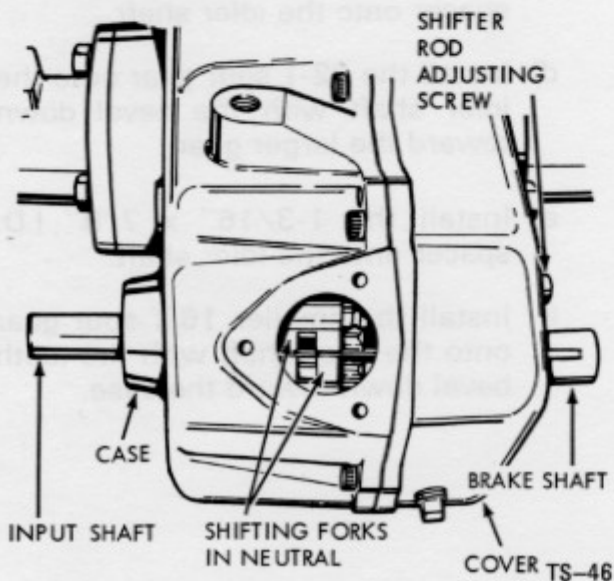

Figure 53 - Transaxle Case

6. Install the shifter assembly (Figure 51) as a unit. The neutral slots (Figure 53) of the shifter forks should align with the case opening.

7. Install the output shaft into the case (Figure 52) and assemble the 32-T output gear, 5/8" x 1-5/16" spacer and a 1/16" x 3/4" I.D. thrust washer onto the output shaft.

8. Install the brake shaft and 30-T spur gear into the cover (tooth bevel up toward the case).

9. Install the cover as follows:
 - a) Align a new gasket on the seal surface of the case.
 - b) Position the cover on the case.
 - c) Align the case and cover with (2) dowel pins.
 - d) Secure case to cover with (8) 1/4-20 x 3/4" socket head cap screws. Torque to 10 ft. lbs.

SECTION III

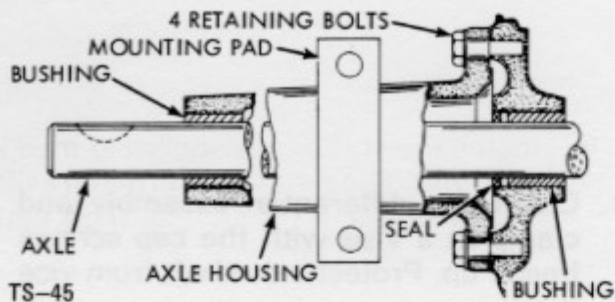

Figure 54 - Bushings and Seal and Axle Housing

TESTING

See Testing on Page 19, SECTION I, of this manual.

10. Install axle seals in case and cover using sleeve and driver.
11. Install axle support housing. (Figure 54) Torque (4 each) the 5/16-18 x 3/4" cap screw to 13 ft. lbs. Be sure mounting pads are correctly positioned.
12. Install shifter lever housing. Use a new gasket. Torque (3) socket head cap screws to 10 ft. lbs.
13. Place 2 pints of S.A.E. E.P. 90 lubricant in the transmission.

SECTION III

DIFFERENTIAL SERVICE

DISASSEMBLY

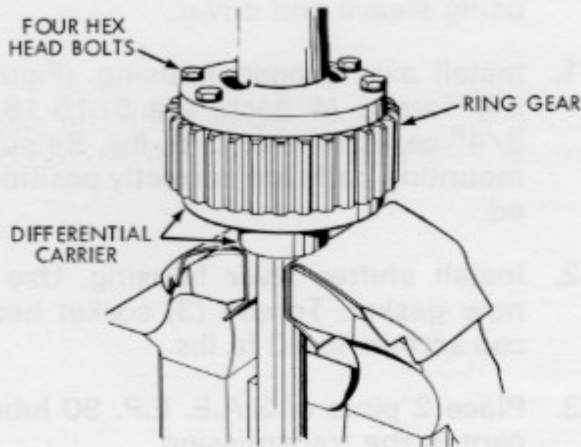

TS-39

Figure 55 - Differential Bolt Removal

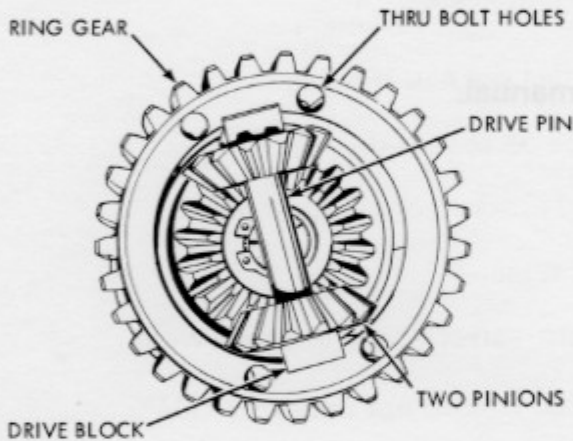

TS-40

Figure 56 - Differential Assembly (One Carrier Removed)

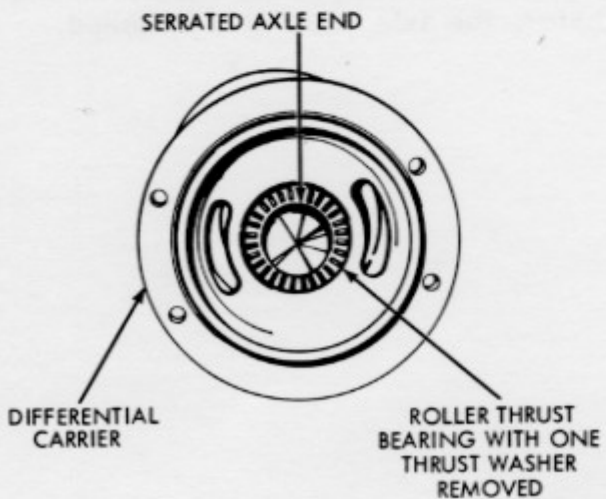

TS-47

Figure 57 - Snap Ring, Washer and Bevel Gear Removed

1. Clean the differential assembly and clamp in a vise with the cap screws heads up. Protect axle shaft from vice jaws.
2. Remove the (4) hex head, Grade 8 cap screws (Figure 55) and lift the upper axle and differential carrier off.
3. Lift drive pin, drive blocks, and pinion gears (Figure 56) from inside of ring gear.
4. Remove ring gear.
5. Remove snap ring and bevel gear (Figure 56) from axle.
6. Remove the thrust washers and roller thrust bearing (Figure 57) from axle.
7. Slide the differential carrier from the axle.

SECTION III

DIFFERENTIAL SERVICE

INSPECTION AND REPAIR

The axle housings contain bushings at the outer end of the housing. With the axle removed, determine the wear. Remove and replace the bushing if worn in excess of .878" I.D.

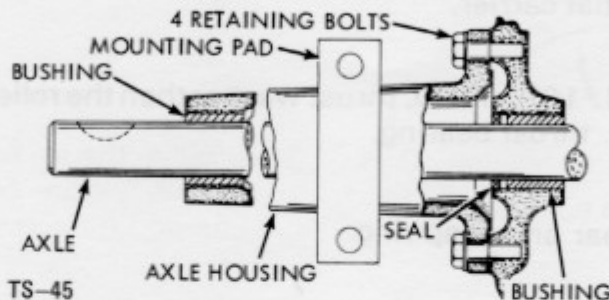

Figure 58 - Bushings and Seal and Axle Housing

Inspect the following items. Repair or replace as required:

Gears and Pinions - Check for wear and cracked or chipped teeth.

Thrust Bearing - Check for pits or roughness.

Thrust Washer - Check for wear. A bright surface may indicate wear.

Differential Carriers - Check for wear. I.D. should not exceed 1.004".

Drive Pin and Drive Blocks - Check for wear.

NOTE: The real seal for the axle housing (Figure 58) should be replaced after the case and cover are assembled and before the axle housing is installed.

SECTION III

DIFFERENTIAL SERVICE

ASSEMBLY

1. Clamp axles in a soft jawed vise with splined end up. Oil all parts and assemble as follows:
 - a) Install differential carrier.
 - b) Install first (1) 1/16" x 1" I.D. thrust washer then the roller thrust bearing and a 1/16" x 1" I.D. thrust bearing.
 - c) Install bevel gear and snap ring.

NOTE: Assemble both axles in this order.

2. Clamp axle assembly with the threaded holes in the differential carrier in a soft jawed vise.
3. Position ring gear on differential carrier.
4. Assemble pinion drive shaft and drive block into ring gear.
5. Align the other axle and carriers with the ring gear.
6. Secure complete assembly with (4) 1/4-20 x 2-1/2" Grade 8 cap screws. Torque to 7 ft. lbs.

TESTING

Test differential action by holding the upper axle vertically and spinning the differential. The unit should spin and rotate freely. Place the assembly on the bench and rotate both axles in different directions. If any binding is noted in either test, check retaining bolt torque; gear meshing, or bearing surfaces in the differential carriers. Little or no end-play should be apparent between the axles and carriers.

SECTION IV

TRANSAXLE SERVICE EGT 150 & EGT 200 (Peerless Model 2318)

TRANSMISSION SERVICE

IDENTIFICATION

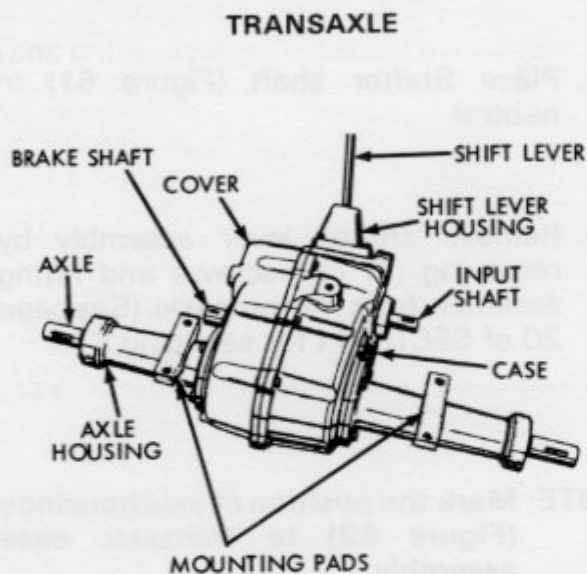

TS-48

Figure 59

RANGE SELECTOR PATTERN

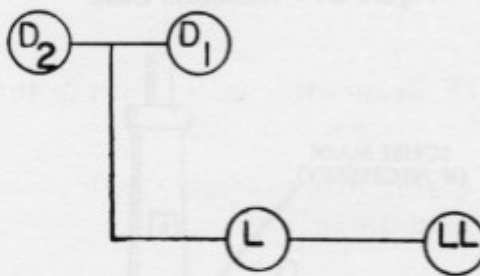

Fig. 60

The transmission of the transaxle used in Avco New Idea electric garden tractor Models EGT 150 and EGT 200 provides four speed range selections (no reverse gear).

Forward and reverse ground speeds in any given transmission range are selected by the operator through an electric speed control.

SECTION IV

TRANSAXLE

DISASSEMBLY

Inspect transaxle and follow removal procedures outlined in "Transaxle Removal Procedures" on page 3 of SECTION I. After removal of transaxle, proceed as follows:

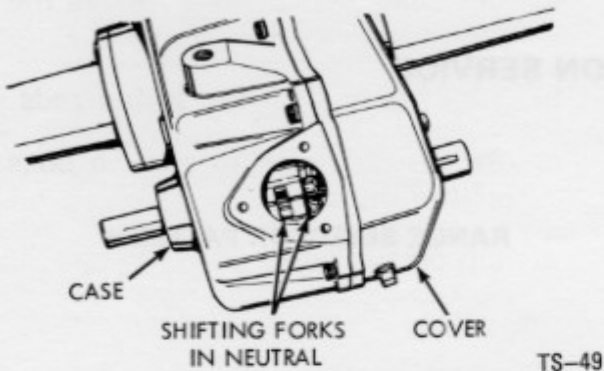

Figure 61 - Transaxle Case

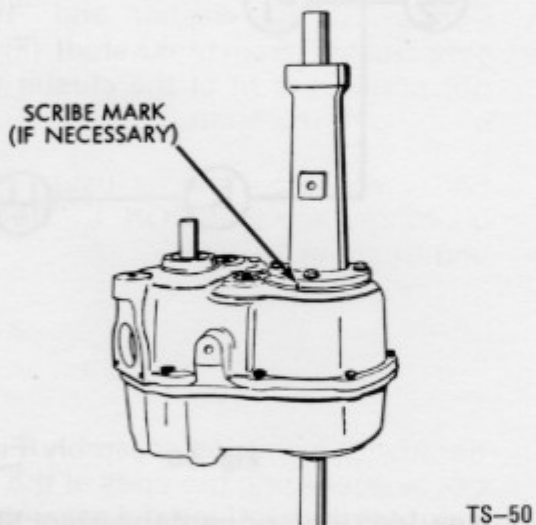

Figure 62 - Remove Axle Housings

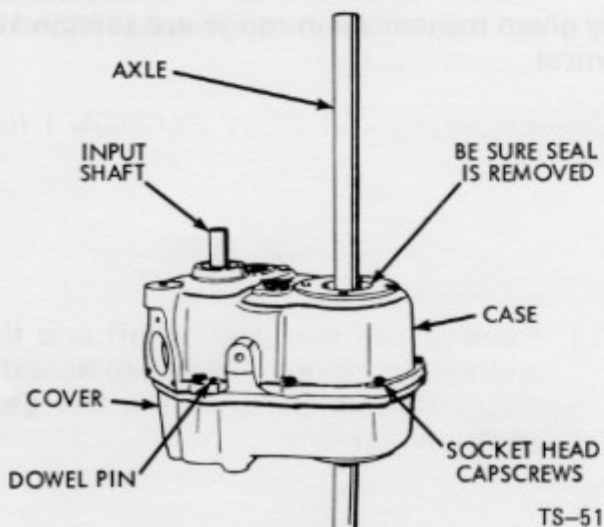

Figure 63

1. Clean transaxle thoroughly and remove all paint, rust and scratches from exposed ends of axles prior to disassembly.
2. Place Shifter shaft (Figure 61) in neutral.
3. Remove shifter lever assembly by removing (3) cap screws and lifting assembly from the transaxle. (See page 20 of SECTION I for servicing.)

NOTE: Mark the position of axle housings (Figure 62) to transaxle case assembly.

4. Remove axle shaft support housings (Figure 62) by removing attaching bolt and sliding the housing off the axle shafts. For servicing see page 51.
5. Remove axle seal and retainer. (Figure 62) Use axle as a driver.
6. Position the transaxle assembly on a disassembly stand with cover half down.
7. Drive dowel pins into the cover (Figure 63) and remove (8) socket head cap screws.

SECTION IV

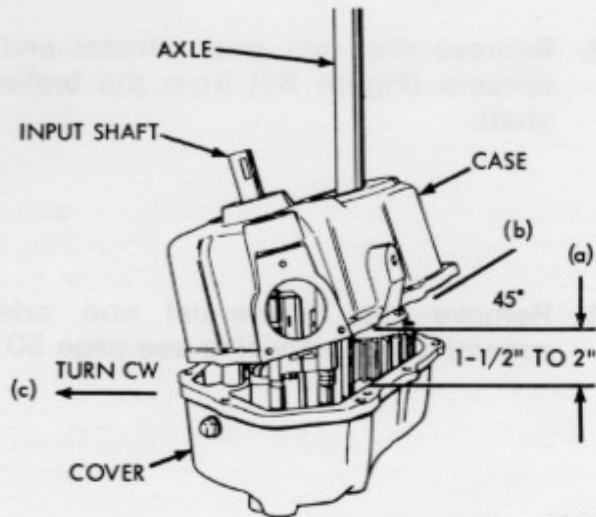

TS-52

Figure 64

8. Remove the case (Figure 64) from the cover as follows:
 - a) Lift case 1-1/2" to 2" above the cover.
 - b) Tilt case to clear the shifter rods.
 - c) Rotate the case to clear a boss within the case.
 - d) Lift off the case.

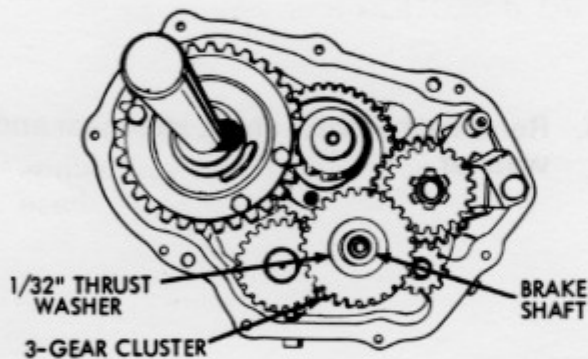

TS-53

Figure 65 - Remove Three Gear Cluster

9. Remove thrust washer and "three gear cluster" from brake shaft, (Figure 65) noting the fit of the cluster gear bushing to the shaft.

For servicing the cluster gear bushings, see SECTION I, "Bearing and Bushing Service".

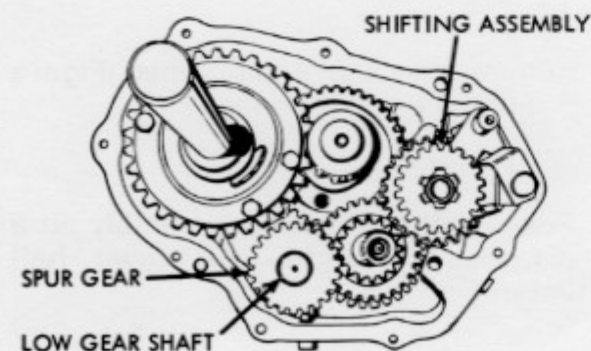

TS-54

Figure 66 - Remove Shifting Assembly

10. Remove the shifting assembly (Figure 66) by squeezing the ends of the shift rods together. Lift out the assembly as a unit. Prior to removal, note the position of the shifter fork and annular grooves to facilitate reinstallation of the assembly.

(See pages 20 and 21 of SECTION I for servicing.)

11. Remove the low gear, shaft and the splined spur gear. (Figure 66) Note the thrust washer between the low gear shaft and cover.

SECTION IV

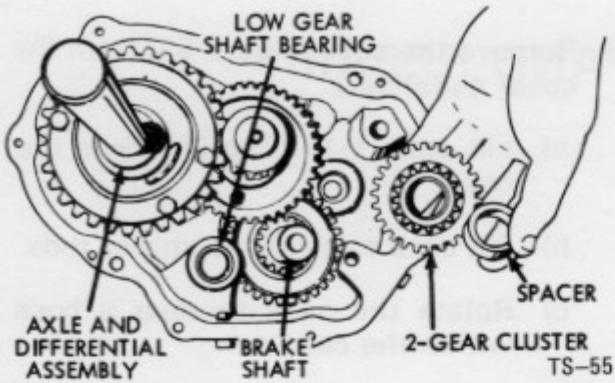

Figure 67 - Brake Shaft

12. Remove the two gear cluster and spacers (Figure 67) from the brake shaft.

13. Remove the differential and axle assembly. For servicing see page 50.

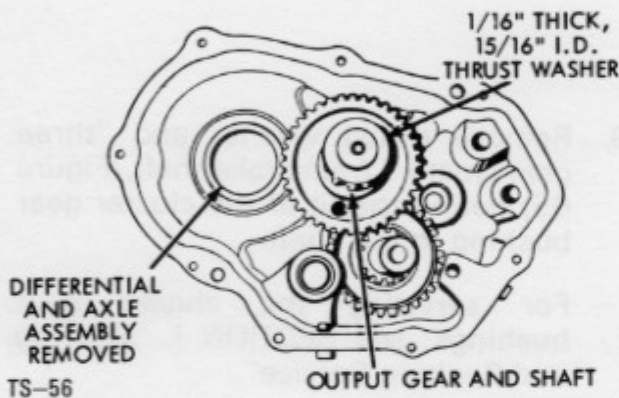
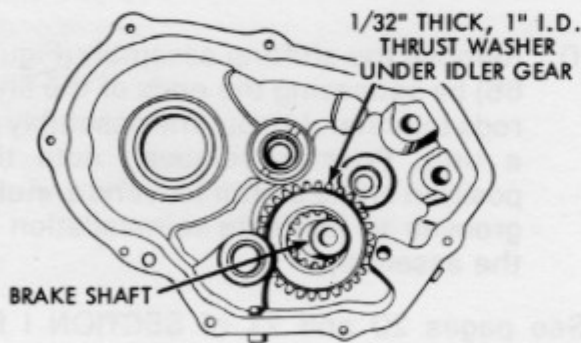

Figure 68 - Output Gear and Shaft

14. Remove the output shaft and gear (Figure 68) and the thrust washers from each end of the shaft.

15. Remove the brake shaft, idler gear and washer.



TS-57

Figure 69 - Idler Gear and Brake Shaft

16. Remove the input shaft from the case. Use a plastic hammer to drive the shaft from case.

SECTION IV

INSPECTION AND REPAIR

1. Gears

- (a) Check bevels for evidence of galling due to improper shifting.
- (b) Check face of teeth for wear. Replace gears indicating damage or excessive wear.

2. Shafts and axles

- (a) Check surfaces for rust, pitting, scratches or wear.
- (b) Check keyways, splines, threads and grooves for wear. Replace parts if worn excessively or damaged.

3. Case and cover

Check for cracks, stripped threads in bolt holes in cover, metal chips, uneven sealing surfaces and rust. Clean out any rust. Replace parts that are damaged and cannot be repaired.

4. Thrust washers and spacers

Check for shininess indicating wear. Replace if wear is evident. Try to determine cause of thrust washer wear such as: lack of end play due to reuse of gasket or use of wrong thrust washer.

5. Shifting assembly

If the shifter assembly needs servicing, (see pages 21 to 23, SECTION I), if not, place it aside, in a clean place, intact, for easy reassembly.

SECTION IV

ASSEMBLY

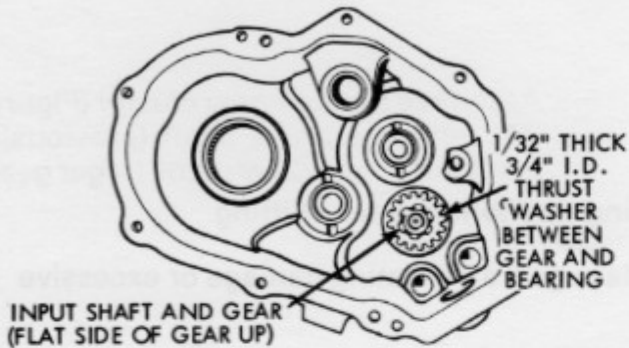

TS-61

Figure 70 - Case Assembly

1. Install input shaft and 16-T spur gear (Figure 70) into case.

NOTE: Install thrust washer next to the cover and assemble spur gear with the flat side of the gear up toward the case. Use a soft mallet to seat gear and shaft.

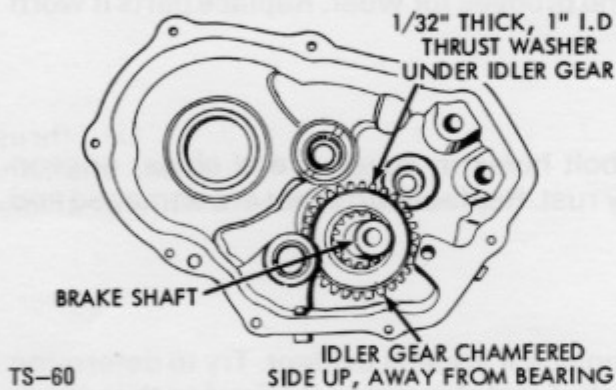

TS-60

Figure 71 - Idler Gear and Brake Shaft

NOTE: Position cover for assembly.

2. Assemble thrust washer and 30 tooth spur gear with chamfer side of the spur gear up toward the case onto the brake shaft, (Figure 71).

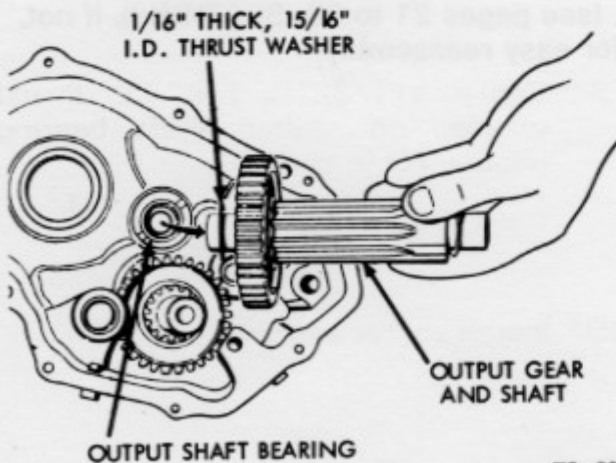

TS-62

Figure 72 - Output Shaft Bearing

3. Install the output shaft with the 36-T bevel gear and a 1/16 x 15/16 I.D. thrust washer (Figure 72) on each end of the shaft into cover assembly.

SECTION IV

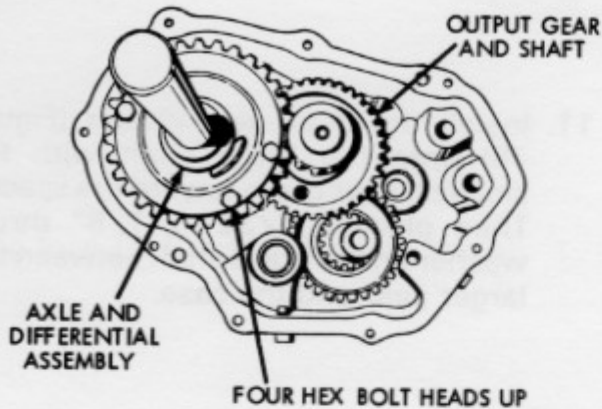

Figure 73 - Install Differential

TS-63

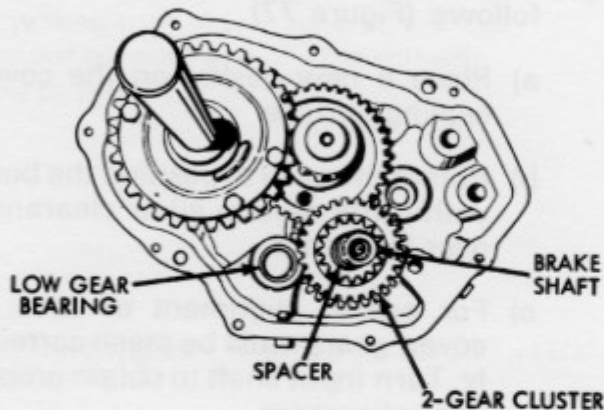

Figure 74 - Two Gear Cluster

TS-64

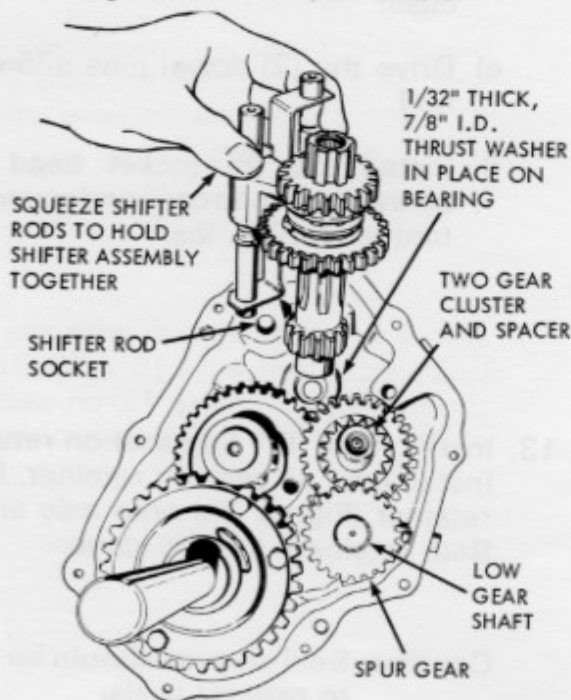

Figure 75 - Spur Gear and Low Speed Shaft

TS-65

4. Install the differential assembly (Figure 73) into the cover with the bolt heads up toward the case.

5. Assemble the two-gear cluster (Figure 74) onto the brake shaft (previously installed in step 2) with the larger gear down.

6. Install the $1/2'' \times 15/16''$ I.D. spacer (Figure 74) onto the brake shaft.

7. Place a $1/16'' \times 3/4''$ I.D. thrust washer (Figure 74) between shaft and low gear bearing. Install low gear idler shaft.

8. Install splined 22-T spur gear (Figure 75) onto low gear idler shaft. Do not install a thrust washer on the exposed end.

9. Center a $1/32'' \times 7/8''$ I.D. thrust washer on shifter shaft bearing (Figure 75) in cover.

10. Install shifter assembly.

NOTE: Install the shifter assembly (Figure 75) with the needle bearing end of the shifter shaft upward.

SECTION IV

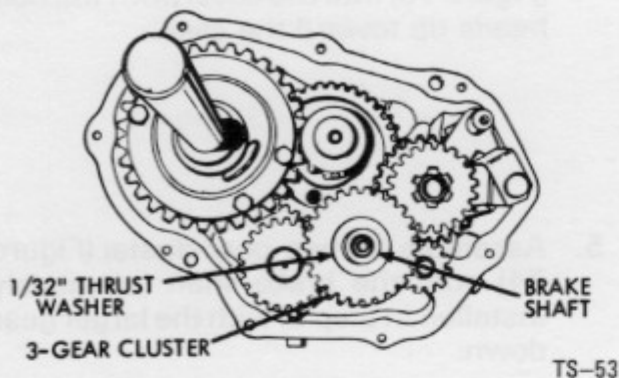

Figure 76 - Three Gear Cluster

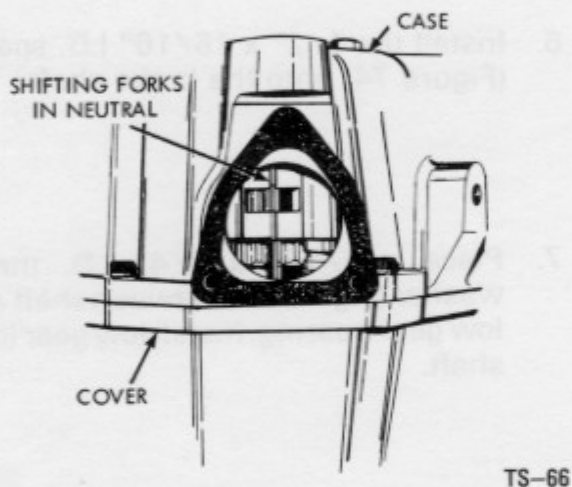

Figure 77 - Install Case

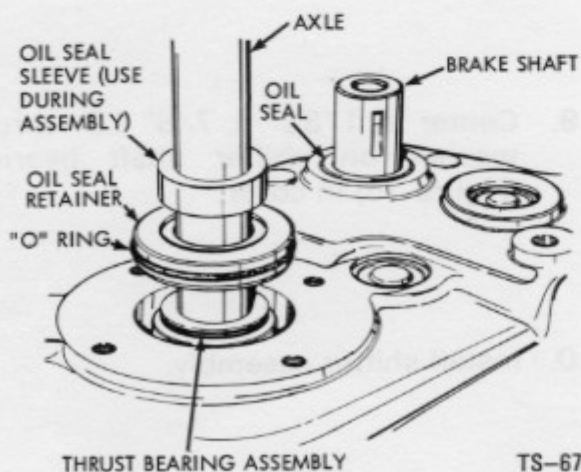

Figure 78 - Install Seal Retainers

11. Install the three-gear cluster (Figure 76) onto the brake shaft with the smallest gear down toward the spacer. Then place a 1/32" x 7/8" thrust washer on the brake shaft between the larger gear and the case.

12. Assemble the case to the cover as follows: (Figure 77)

- a) Place a new gasket on the cover sealing surface.
- b) Rotate the case to position the boss within the case to allow clearance over the gears.
- c) For proper alignment of case to cover, gears must be mesh correctly. Turn input shaft to obtain proper gear alignment.
- d) Use a needle nose pliers to align the shifter rods into position in the case.
- e) Drive the (2) dowel pins into case half.
- f) Install the (8) socket head cap screws between case and cover and torque to 10 ft. lbs.

13. Install new "O" ring seal on retainer. Install new oil seals in retainer. Place retainer (Figure 78) onto axle shafts. Both retainers are the same.

Caution: Seal sleeves should be used to protect seals.

SECTION IV

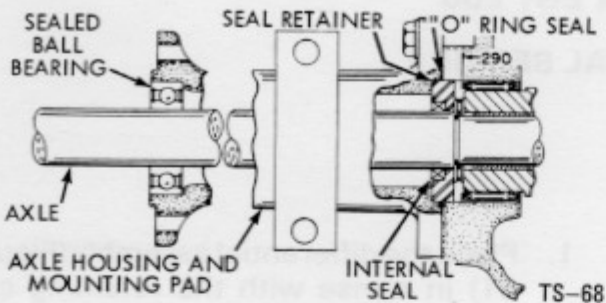

Figure 79 - Bushing and Seal Assembly, Axle Housing

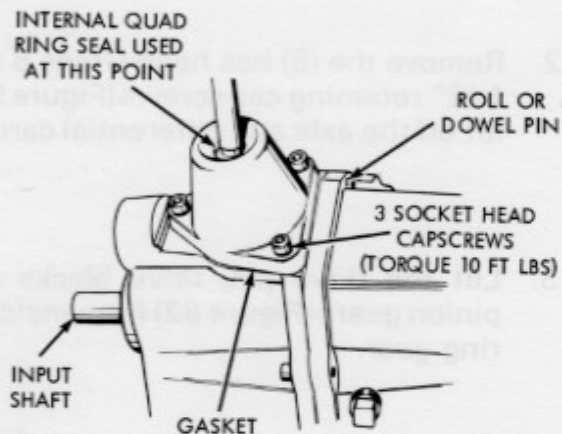

Figure 80 - Shift Lever Housing Installed

14. Assemble axle housing (Figure 79) as follows:

- Place new "O" ring on oil seal retainer.
- Position axle mounting pads in original position as marked when removed.
- Torque retaining cap screws to 13 ft. lbs.

15. Install shifter lever housing assembly. (Figure 80) Use a new gasket. Torque three (3) socket head cap screws to 10 ft. lbs.

16. Place three (3) pints of S.A.E. - E.P. 90 in the transmission.

TESTING

See testing on page 19, SECTION I of this manual.

SECTION IV

EGT 150 & EGT 200 DIFFERENTIAL SERVICE

DISASSEMBLY

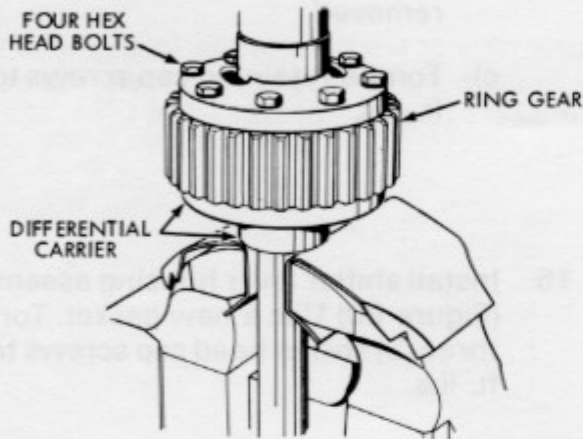

TS-70

Figure 81 - Differential Bolt Removal

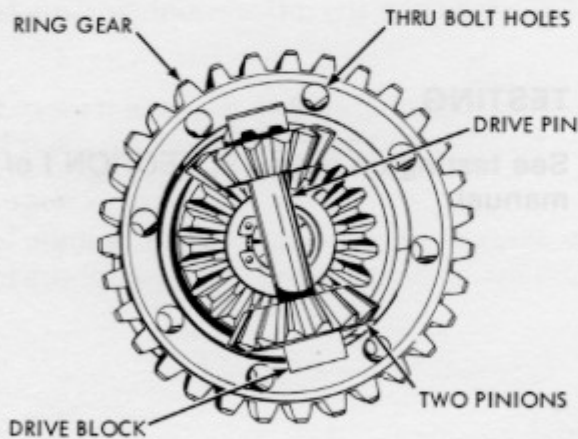

TS-71

Figure 82 - Differential Assembly (One Carrier Removed)

1. Place the differential assembly (Figure 81) in a vise with the retaining cap screws up. Clamp the vise jaws onto the axle below the bearing surface of the differential carrier. Protect axle from vise jaws.
2. Remove the (8) hex head Grade 8 x 2-1/2" retaining cap screws (Figure 81); lift off the axle and differential carrier.
3. Lift the drive pin, drive blocks and pinion gears (Figure 82) from inside of ring gear.
4. Remove ring gear.
5. Remove snap ring and 1/32" x 7/8" I.D. flat washer.
6. Remove pinion gear and 1/8" x 7/8" I.D. spacer from axle.
7. Lift off differential carrier, and 1/32" x 7/8" thrust washer and thrust bearing from axle shaft.

SECTION IV

EGT 150 & EGT 200 DIFFERENTIAL SERVICE

INSPECTION

1. The axle housings contain sealed ball bearings at the outer ends. With the axle removed, rotate the inner race with the fingers. If any roughness is felt, replace bearings. See "Bearing and Bushing Service", page 13 of SECTION I.

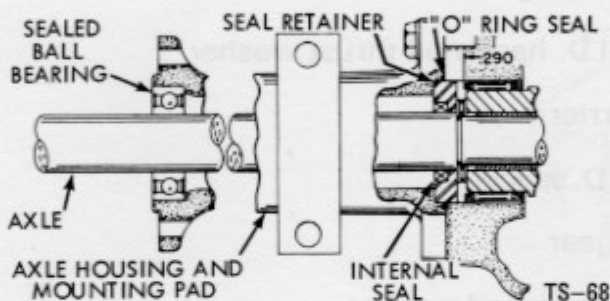

Figure 83 - Bushing and Seal Assembly, Axle Housing

2. Examine the external bearing race (1) (Figure 84) on the differential carriers for wear or pitting. Replace if evident.
3. The differential carriers have internal bushings (2) (Figure 84). Replace if worn in excess of 0.878" I.D. (A) (Figure 84). See "Bearing and Bushing Service", page 13 of SECTION I.
4. Examine gears and pinions for wear; cracked or chipped teeth. Check splines for excess play. Inspect drive pin, drive blocks, thrust bearing and thrust washers for wear. Replace as required.

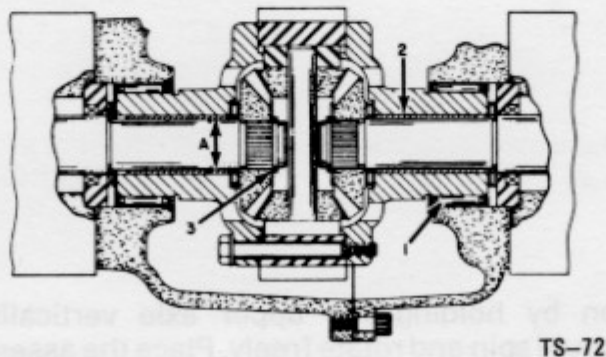

Figure 84

SECTION IV

EGT 150 & EGT 200 DIFFERENTIAL SERVICE

ASSEMBLY

1. Clamp one axle in a vise. Protect axle shaft from vice jaws. Oil all parts and assemble onto axle shaft in the following sequence:
 - a) Flanged thrust washer
 - b) Roller thrust bearing
 - c) 1/32" x 7/8" I.D. hardened thrust washer
 - d) Differential carrier
 - e) 1/8" x 7/8" I.D. spacer
 - f) Splined bevel gear
 - g) 1/32" x 7/8" hardened washer
 - h) Snap ring
2. Assemble second axle using the same procedure as listed above.
3. Clamp the axle assembly in a vise. Place the differential carrier with the threaded bolt holes onto the axle shaft.
4. Position ring gear on carrier and align bolt holes.
5. Assemble drive pin, drive blocks and pinion gears into ring gear.
6. Place other axle assembly on ring gear and align bolt holes.
7. Install (8) 1/4-20 x 2-1/2" hex head cap screws with lock washer. Torque to 7 ft. lbs.

TESTING

Test differential action by holding the upper axle vertically, and spinning the differential. The unit should spin and rotate freely. Place the assembly on the bench and rotate both axles in different directions. If any binding is noted in either test, check retaining bolt torque, gear meshing, or bearing surfaces in the differential carriers. Little or no end-play should be apparent between the axles and carriers.

SECTION V

R-36

TRANSMISSION SERVICE

IDENTIFICATION

The R-36 Transmission provides five forward speeds and one reverse speed.

TRANSMISSION

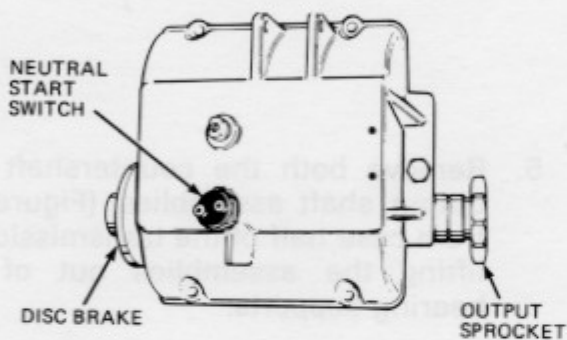

TS-73

Figure 85

RANGE SELECTOR PATTERN

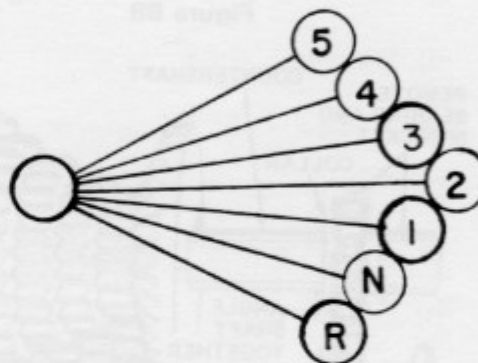

Figure 87

DISASSEMBLY

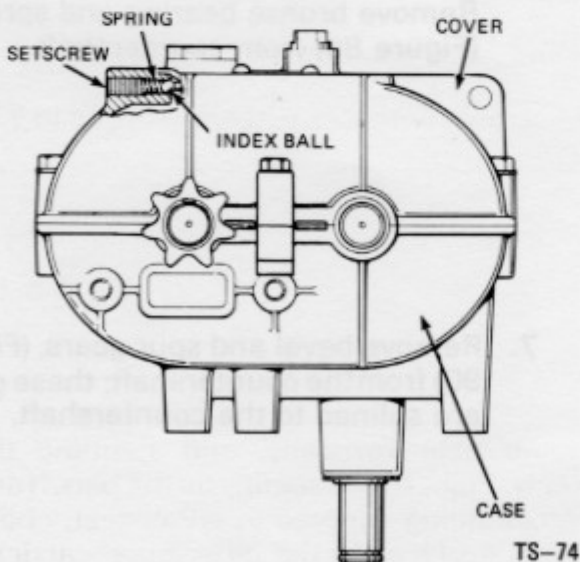
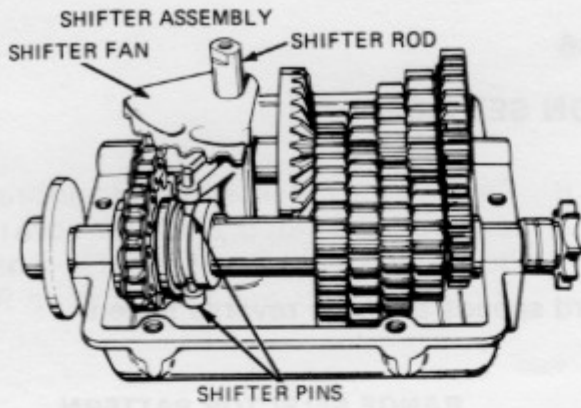

Figure 86

1. Clean outside surface of transmission. Position shift lever in neutral position (Figure 87) as indicated by shift pattern. Remove neutral start switch. (Figure 85)
2. Remove set screw, spring and index ball from transmission cover. (Figure 86)
3. Clean paint from shifter shaft. Remove six cap screws that retain cover to case. Remove cover.

SECTION V



TS-76

Figure 88

4. Remove shifter assembly (Figure 88) (includes shaft, pins and fan) from transmission case by lifting assembly out of the case.

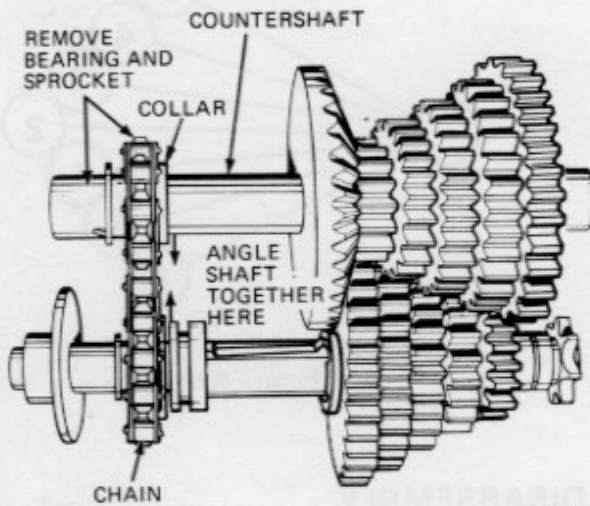

TS-77

Figure 89

5. Remove both the countershaft and output shaft assemblies, (Figure 89) from case half of the transmission by lifting the assemblies out of the bearing supports.

6. Angle the two shaft ends toward each other, (Figure 89) and remove chain.

Remove bronze bearing and sprocket, (Figure 89) from countershaft.

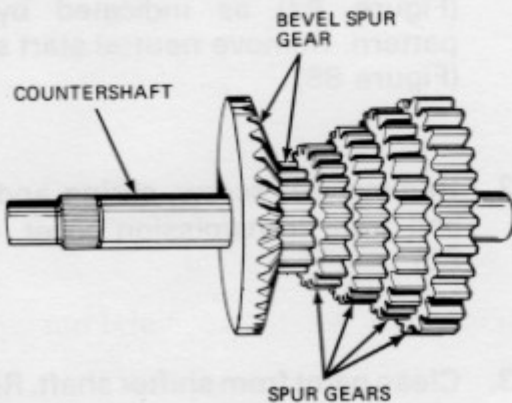

TS-78

Figure 90

7. Remove bevel and spur gears, (Figure 90) from the countershaft; these gears are splined to the countershaft.

SECTION V

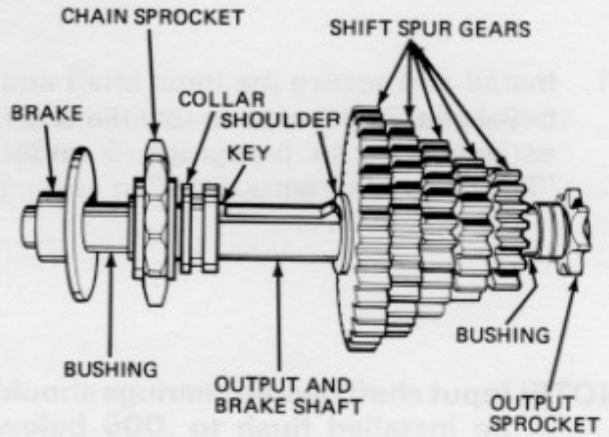

TS-79

Figure 91

8. Remove the output sprocket and brake disc from the output shaft. Remove the bushings, shift spur gears, chain sprocket, collar and keys. (Figure 91)

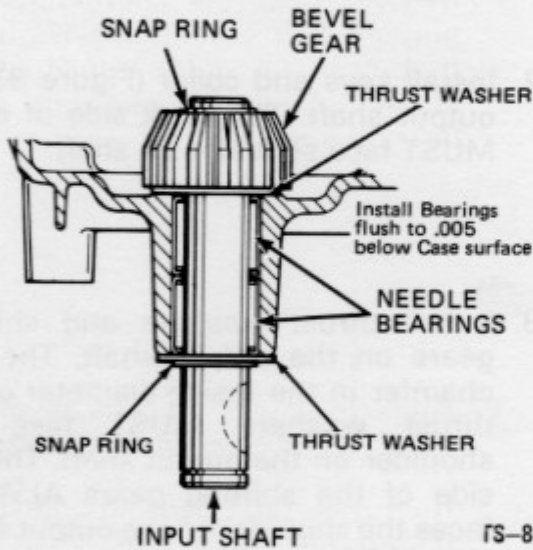

TS-80

Figure 92

9. Remove snap ring from input shaft, remove bevel gear and pull shaft through case. (Figure 92)

INSPECTION AND REPAIR

1. Examine all parts after removing grease with cleaning solvent.
2. Replace all worn or damaged parts, such as gears, shafts, keys and bushings.

SECTION V

REASSEMBLY

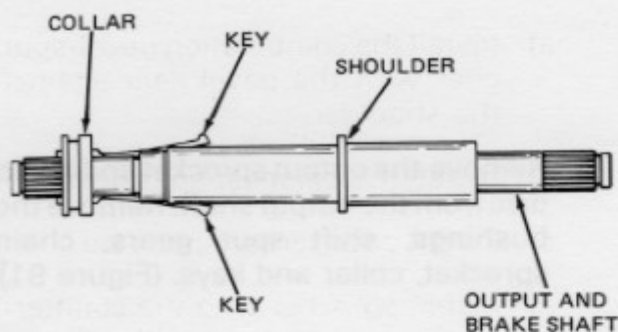

Figure 93

TS-81

1. Install and secure the input shaft and bevel gear in the case in reverse order as described in paragraph 9 under "Disassembly Instructions".

NOTE: Input shaft needle bearings should be installed flush to .005 below bearing bore surfaces from inside and outside case.

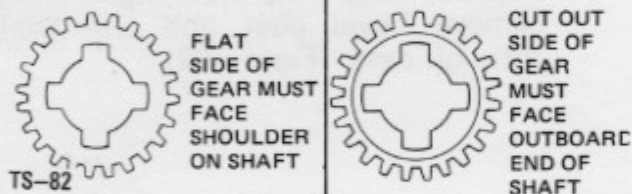
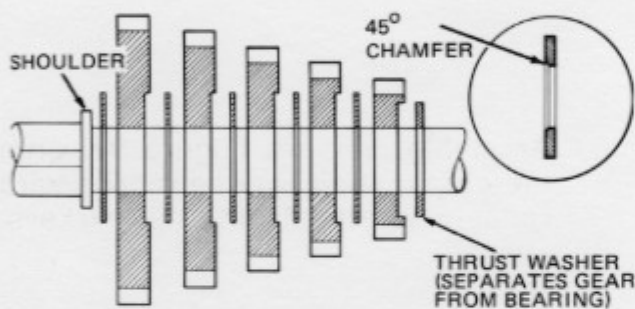

Figure 94

2. Install keys and collar (Figure 93) on output shaft. The thick side of collar **MUST** face shoulder on shaft.

3. Install thrust washers and shifting gears on the output shaft. The 45° chamfer in the inside diameter of the thrust washers **MUST** face the shoulder on the output shaft. The flat side of the shifting gears **ALWAYS** faces the shoulder on the output shaft. (Figure 94)

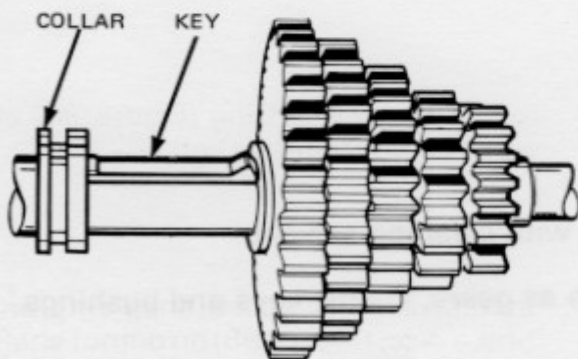
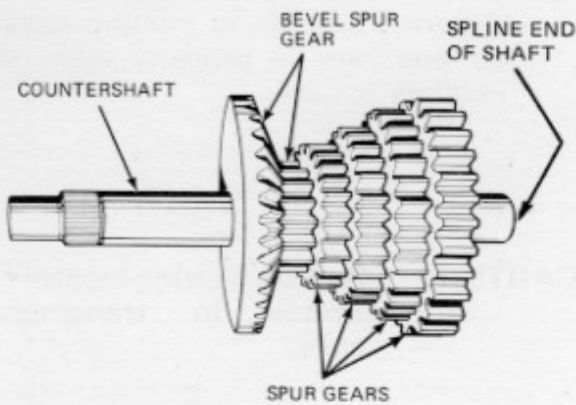

Figure 95

TS-83 When correctly assembled, the output shaft should appear as shown in Figure 95.

NOTE: The thickest thrust washer on the shift gear end (opposite the shoulder) of the output shaft does not have a chamfer on the inside diameter and must be positioned next to the smallest gear.

SECTION V



TS-84

Figure 96

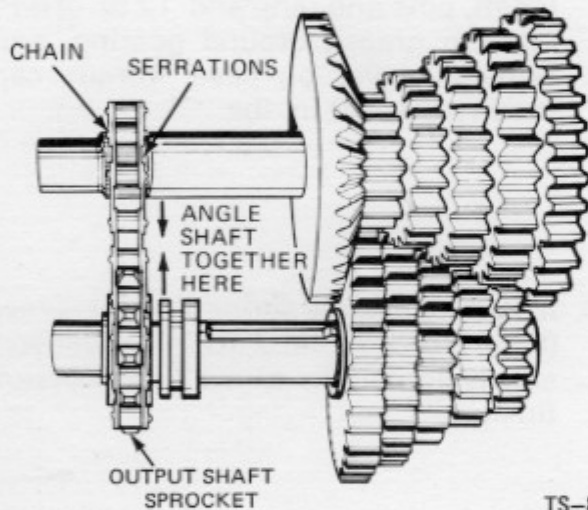

TS-85

Figure 97

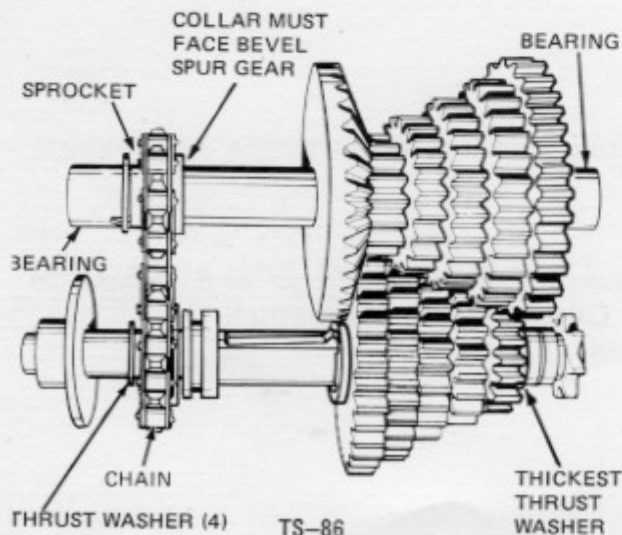

TS-86

Figure 98

4. Assemble the countershaft as follows (Figure 96):
 - a) Install the combination bevel-spur gear with the bevel gear against the shoulder.
 - b) Install the smallest spur gear
 - c) Install each larger spur gear
 - d) Install sprocket onto the countershaft over serrations with collar of sprocket facing the bevel gear.
 - e) Install thrust washer and bronze bushing on each end of countershaft.

5. Assemble sprocket (Figure 97) onto the output shaft over serrations with collar of sprocket facing shifting keys.

6. Angle the two shafts together (Figure 97) and install chain, and align sprockets.

7. Install thrust washers on output shaft, (Figure 98) (the thickest thrust washer must be positioned on the shifting gear end of the output shaft).

8. Install bronze bearing (Figure 98) on each end of output shaft.

9. Install drive sprocket, snap ring and brake disc, (Figure 98) on output shaft.

SECTION V

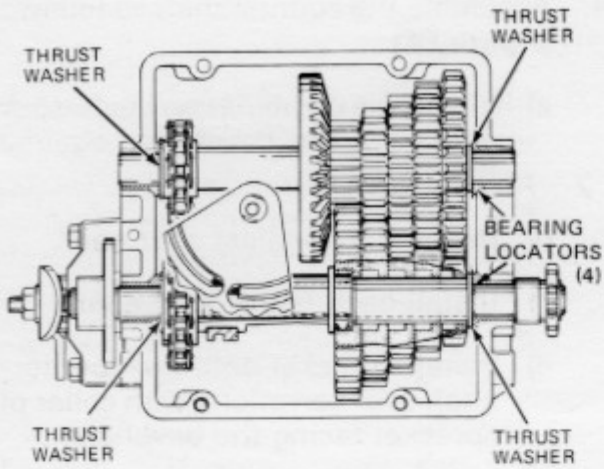

Figure 99

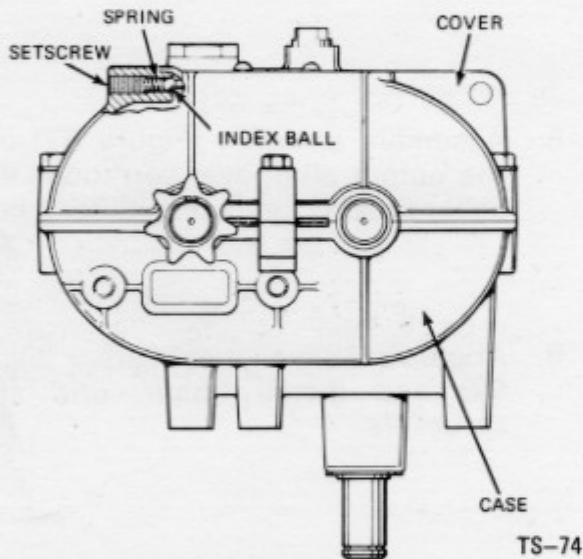

Figure 100

8. Install shaft assemblies into case, (Figure 99) utilizing piloting locators on bearings to properly align with notches in case.

CAUTION: Be sure bearing locators are seated in transmission case.

9. Install shifter assembly (Figure 99) (shaft, pins and fan), and 12 oz. of E.P. Lithium grease around gearing, and reinstall cover on case. Torque cap screws 90-100 in. lbs.

10. Install index ball, spring and set screw (Figure 100) in that order into cover and slowly tighten the screw 2 turns below flush.

TESTING

To check for binding, turn input shaft. If binding occurs disassemble and recheck components.

NOTE: Install transmission on unit. Install brake and linkage and adjust to disengage when clutch is engaged. Consult Owner's Manual.

SECTION V

DIFFERENTIAL SERVICE

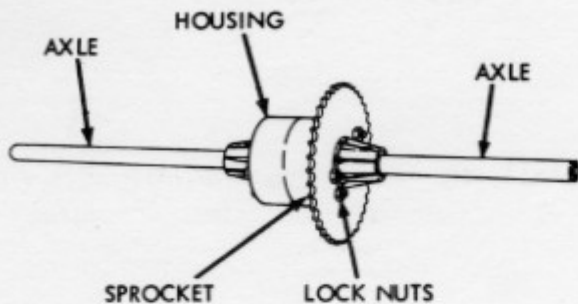

Figure 101

TS-88

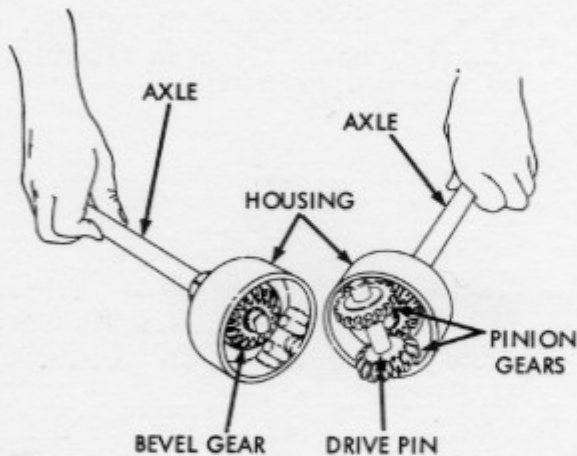
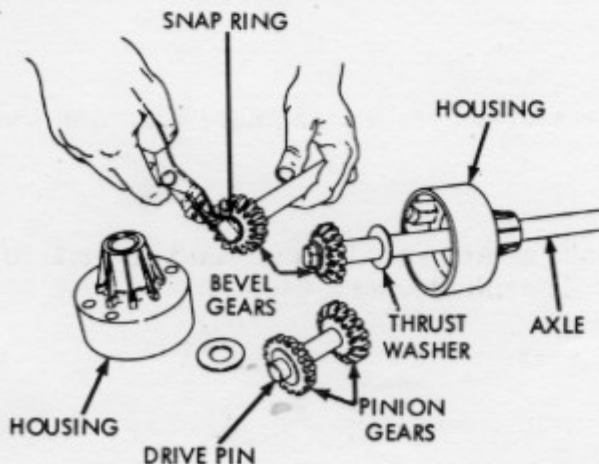

Figure 102

TS-89



TS-90

DISASSEMBLY

1. Clean outside of differential. Remove all burrs from both shafts.
2. Remove (4) lock nuts and cap screws, Figure 101 from housing. Remove sprocket and separate differential carrier housings.
3. Remove drive pin, pinion gears and thrust washers, Figure 102 as a unit.
4. Remove snap ring, bevel gear and thrust washer, Figure 103 from axle shaft. Slide axle from differential carrier housing.

INSPECTION & REPAIR

1. Examine all parts after removing grease with cleaning solvent.
2. Replace all worn or damaged parts.
3. Bushings are replaceable in differential carrier housing. For bushing replacement (see Bushing Service Section I-Page 14).

ASSEMBLY

1. Slide axle into differential housing. Place thrust washer and bevel gear on axle and secure with snap ring.
2. Place pinion gears and thrust washers on drive pin and insert assembly into differential housing carrier.
3. Place 1 oz. of S.A.E. - E.P. 90 Lithium grease into either differential housing carrier.
4. Assemble differential carrier housings with drive sprocket using 4 bolts and lock nuts previously removed.

NOTE: No oil seals or gaskets are required in this unit.

REMARKS

1. [Faint, illegible text]

2. [Faint, illegible text]

3. [Faint, illegible text]

4. [Faint, illegible text]

5. [Faint, illegible text]



1. [Faint, illegible text]

2. [Faint, illegible text]

3. [Faint, illegible text]

4. [Faint, illegible text]

5. [Faint, illegible text]



1. [Faint, illegible text]

2. [Faint, illegible text]

3. [Faint, illegible text]

4. [Faint, illegible text]

5. [Faint, illegible text]



1. [Faint, illegible text]

